

## RESOLUCION 737 - SUBTEL

Fecha de publicación: 13/3/2026

### Información Comercial

#### Nombre comercial del equipo

Código	Descripción
929003499606	Sync Box 8K IN LATAM

**Fabricante:** Signify (China) Investment Co., Ltd.

**Importador o representante en Chile:** SIGNIFY CHILENA S.A.

**Domicilio:** El Bosque Norte 0211, Las Condes - Santiago

**Correo electrónico de contacto:** tomas.aragona@signify.com

**Sitio Web:** philips-hue.com/es-cl

### Características técnicas

Tipo de equipo	Caja de sincronización Smart
Marca	Hue
Modelo	Sync Box 8K IN LATAM
Módulo	ESP32-WROOM-2
Tecnología o modulación	GFSK (BLE); DSSS-DBPSK, DQPSK, CCK, OFDM-BPSK, QPSK, 16QAM, 64QAM (WLAN)
Frecuencias	BLE: 2402 – 2480MHz - WLAN 2.4GHz: 2412 – 2472MHz
Ganancia de antena (dBi)	2.4 dBi
P.I.R.E. (EIRP)	BLE: 9.99 dBm; WLAN: 19.95 dBm

### Declaración de conformidad

*“El equipo previamente individualizado cumple con las disposiciones establecidas en la Norma Técnica de Equipos de alcance reducido, aprobada por la resolución exenta N° 1.985, de 2017, de la Subsecretaría de Telecomunicaciones.”*

Firma del Importador/Responsable:

Nombre de quien firma: Tomás Aragona



Cargo: Representante Legal

- ANT.: 1) Nota ingreso Subtel N° 137.215 de 24.10.2024.  
2) Resolución Exenta N° 1.985 de 2017 y sus modificaciones, de la Subsecretaría de Telecomunicaciones.  
3) Resolución Exenta N° 2.844 de 2022, de la Subsecretaría de Telecomunicaciones.  
4) Ley N° 18.168, General de Telecomunicaciones.  
5) Resolución Exenta N° 470 de 13.02.2013, que Faculta a los Jefes de División y de Departamento para firmar “Por orden del Subsecretario de Telecomunicaciones” y delega las facultades que indica.

MAT.: Certifica equipo de alcance reducido.

DE : SUBSECRETARÍA DE TELECOMUNICACIONES

A : MBSERVICES

1. De acuerdo a la información proporcionada por documento de ANT. 1), esta Subsecretaría de Estado extiende el presente certificado para operar dentro del país, condicionado al estricto cumplimiento de lo señalado en letra j.1) del artículo 1° de la norma de ANT. 2).

Tipo de equipo	Sync box 8K IN LATAM
Marca	HUE
Modelo(s)	9290034996
Fabricante	Signify (China) Investment Co., Ltd.
Frecuencia de operación	BLE: 2402 – 2480MHz WLAN 2.4GHz: 2412 – 2472MHz
Potencia máxima radiada	BLE: 9.99 dBm 2.4GHz: 19.95 dBm
Restricciones	Sin restricciones

2. El incumplimiento de lo dispuesto en el presente certificado, será sancionado de acuerdo a las disposiciones legales vigentes. Estos equipos no deberán provocar interferencias a servicios de concesionarias de telecomunicaciones y no estarán protegidos respecto de interferencias que eventualmente puedan recibir.

Saluda atentamente a Ud.,  
Por orden del Subsecretario de Telecomunicaciones,

DISTRIBUCIÓN:

- MBSERVICES.: Ignacio.Ortega@mbservices.cl
- Oficina de Partes.

Francisco Javier Pizarro Sepulveda  
Jefe División Fiscalización  
20/11/2024 14:51



# Radio Test Report

**Equipment** : HDMI Sync Box  
**Brand Name** : PHILIPS  
**Model Name** : 9290034996  
**Applicant** : Signify (China) Investment Co., Ltd.  
Building 9, Lane 888, Tianlin Road,  
Minhang District, Shanghai 200233 China  
**Manufacturer** : Signify (China) Investment Co., Ltd.  
Building 9, Lane 888, Tianlin Road,  
Minhang District, Shanghai 200233 China  
**Standard** : EN 300 328 V2.2.2 (2019-07)

The product was received on Sep. 23, 2022, and testing was started from Oct. 15, 2022 and completed on Nov. 07, 2022. We, SPORTON INTERNATIONAL INC. Hsinhua Laboratory, would like to declare that the tested sample has been evaluated in accordance with the procedures given in EN 300 328 V2.2.2 (2019-07) and shown compliance with the applicable technical standards.

The test results in this variant report apply exclusively to the tested model / sample. Without written approval of SPORTON INTERNATIONAL INC. Hsinhua Laboratory, the test report shall not be reproduced except in full.



Approved by: Jackson Tsai

**SPORTON INTERNATIONAL INC. Hsinhua Laboratory**

No.52, Huaya 1st Rd., Guishan Dist., Taoyuan City 333411, Taiwan (R.O.C.)



# Table of Contents

**HISTORY OF THIS TEST REPORT .....4**

**SUMMARY OF TEST RESULT .....5**

**1 GENERAL DESCRIPTION .....6**

1.1 Information.....6

1.2 Testing Applied Standards .....9

1.3 Testing Location Information .....9

1.4 Measurement Uncertainty .....9

**2 TEST CONFIGURATION OF EUT.....10**

2.1 Test Condition .....10

2.2 Test Channel Mode .....10

2.3 The Worst Case Measurement Configuration.....11

2.4 Accessories .....12

2.5 Support Equipment.....12

2.6 Test Setup Diagram .....13

**3 TRANSMITTER TEST RESULT .....14**

3.1 RF Output Power .....14

3.2 Power Spectral Density .....16

3.3 Occupied Channel Bandwidth .....19

3.4 Transmitter Unwanted Emissions in the Out-of-band Domain .....21

3.5 Transmitter Unwanted Emissions in the Spurious Domain .....24

**4 RECEIVER TEST RESULT .....28**

4.1 Receiver Spurious Emissions.....28

**5 ADAPTIVITY TEST RESULT .....31**

5.1 Adaptivity .....31

**6 RECEIVER BLOCKING TEST RESULT .....33**

6.1 Receiver Blocking.....33

**7 TEST EQUIPMENT AND CALIBRATION DATA .....37**

**APPENDIX A. TEST RESULTS OF RF OUTPUT POWER**

**APPENDIX B. TEST RESULTS OF POWER SPECTRAL DENSITY**

**APPENDIX C. TEST RESULTS OF OCCUPIED CHANNEL BANDWIDTH**

**APPENDIX D. TEST RESULTS OF TRANSMITTER UNWANTED EMISSIONS IN THE OOB DOMAIN**

**APPENDIX E. TEST RESULTS OF TRANSMITTER UNWANTED EMISSIONS IN THE SPURIOUS DOMAIN**



**APPENDIX F. TEST RESULTS OF RECEIVER SPURIOUS EMISSIONS**

**APPENDIX G. TEST RESULTS OF ADAPTIVITY**

**APPENDIX H. TEST RESULTS OF RECEIVER BLOCKING**

**APPENDIX I. TEST PHOTOS**

**PHOTOGRAPHS OF EUT v01**





### Summary of Test Result

Report Clause	Ref Std. Clause	Test Items	Result (PASS/FAIL)	Remark
3.1	4.3.2.2	RF Output Power	PASS	-
3.2	4.3.2.3	Power Spectral Density	PASS	-
5.1	4.3.2.6	Adaptivity	PASS	-
3.3	4.3.2.7	Occupied Channel Bandwidth	PASS	-
3.4	4.3.2.8	Transmitter unwanted emissions in the out-of-band domain	PASS	-
3.5	4.3.2.9	Transmitter unwanted emissions in the spurious domain	PASS	-
4.1	4.3.2.10	Receiver spurious emissions	PASS	-
6.1	4.3.2.11	Receiver Blocking	PASS	-
1.1.8	4.3.2.12	Geo-location capability	N/A	-

**Declaration of Conformity:**

The test results with all measurement uncertainty excluded are presented in accordance with the regulation limits or requirements declared by manufacturers.

**Comments and explanations:**

None

Reviewed by: Ryan Hsiao

Report Producer: Amber Chiu

# 1 General Description

## 1.1 Information

### 1.1.1 RF General Information

Frequency Range (MHz)	IEEE Std. 802.11	Ch. Frequency (MHz)	Channel Number
2400-2483.5	b, g, n (HT20)	2412-2472	1-13 [13]
2400-2483.5	n (HT40)	2422-2462	3-11 [9]

Band	Mode	BWch (MHz)	Nant
2.4-2.4835GHz	802.11b	20	1TX
2.4-2.4835GHz	802.11g	20	1TX
2.4-2.4835GHz	802.11n HT20	20	1TX
2.4-2.4835GHz	802.11n HT40	40	1TX

**Note:**

- ◆ 11b mode uses a combination of DSSS-DBPSK, DQPSK, CCK modulation.
- ◆ 11g, HT20 and HT40 use a combination of OFDM-BPSK, QPSK, 16QAM, 64QAM modulation.
- ◆ BWch is the nominal channel bandwidth.

### 1.1.2 Antenna Information

Ant.	Brand	Model Name	Antenna Type	Connector	Gain (dBi)
1	ESPRESSIF	ESP32-S3-WROOM-2	PIFA antenna	N/A	2.4

Note 1: The EUT has one antenna.

**For 2.4GHz function:**

For IEEE 802.11 b/g/n mode (1TX/1RX)

Ant. 1 could transmit/receive.

**For BT function:**

For IEEE 802.15.1 Bluetooth mode (1TX/1RX)

Ant. 1 could transmit/receive.



1.1.3 EUT Information

Operational Condition			
EUT Power Type	From AC Adapter		
Beamforming Function	<input type="checkbox"/> With beamforming	<input checked="" type="checkbox"/> Without beamforming	
Software / Firmware Version for Adaptivity & Receiver Blocking	ESP32S3_ESP32S3_Signaling_20221031.bin		
Type of EUT			
<input checked="" type="checkbox"/>	Stand-alone		
<input type="checkbox"/>	Combined (EUT where the radio part is fully integrated within another device)		
	Combined Equipment - Brand Name / Model No.: ...		
<input type="checkbox"/>	Plug-in radio (EUT intended for a variety of host systems)		
	Host System - Brand Name / Model No.: ...		
<input type="checkbox"/>	Other:		

1.1.4 Test Duty Cycle

Mode	DC	DCF (dB)
802.11b_Nss1,(1Mbps)_1TX	0.922	0.353
802.11g_Nss1,(6Mbps)_1TX	0.934	0.297
802.11n HT20_Nss1,(MCS0)_1TX	0.933	0.301
802.11n HT40_Nss1,(MCS0)_1TX	0.935	0.292

1.1.5 Table for Multiple Listing

Table for Explanation of 2nd Source.

Object/part or Description (location)	Location	Main source (SKU 1)	2nd source (SKU 2)
level shift	U37	Brand: UTC Model: ULSF0204G-P14-R	Brand: TI Model: LSF0204PWR
Power IC	U2	Brand: GMT Model: G5335QT1U	Brand: ANPEC Model: APW8713EQBI-TRG
IO IC	U27,U56	Brand: NOVOSENSE Model: NCA9555	Brand: NXP Model: PCA9555APW
Fuse	F1	Brand: Littelfuse Model: 2016L260/24	Brand: PTTC Model: 2016P260TF/24

From the above SKU, all of SKUs were verified and Main source (SKU 1) was selected as representative SKU for the test and its data was recorded in this report.

**1.1.6 Table for Existing Change**

This product is an extension of original one reported under Sporton project number: ER271604AC  
 Below is the table for the change of the product with respect to the original one.

Modifications	Performance Checking
1. Change thermal absorber 2. Add 5pcs gasket	1. The worst case of Radiated Unwanted Emissions was evaluated, and the test result of original report was found to be the worst case scenario. 2. Photographs of EUT.

**1.1.7 Adaptive Equipment**

Adaptive Equipment	
<input type="checkbox"/>	non-Adaptive Equipment
<input checked="" type="checkbox"/>	Adaptive Equipment without the possibility to switch to a non-adaptive mode:
<input type="checkbox"/>	Maximum declared RF Output power of less than 10 dBm e.i.r.p.
<input checked="" type="checkbox"/>	The equipment has implemented an LBT based DAA mechanism:
<input type="checkbox"/>	The equipment is Frame Based equipment
<input checked="" type="checkbox"/>	The equipment is Load Based equipment
<input type="checkbox"/>	The equipment can switch dynamically between Frame Based and Load Based equipment
<input type="checkbox"/>	The equipment has implemented an non-LBT based DAA mechanism
<input type="checkbox"/>	The equipment can operate in more than one adaptive mode
<input type="checkbox"/>	Adaptive Equipment which can also operate in a non-adaptive mode

**1.1.8 Geo-location capability supported by the equipment**

Geo-location capability supported by the equipment	
<input type="checkbox"/>	Yes
<input type="checkbox"/>	The geographical location determined by the equipment as defined in EN 300 328, clause 4.3.2.12.3 is not accessible to the user.
<input checked="" type="checkbox"/>	No

## 1.2 Testing Applied Standards

According to the specifications of the manufacturer, the EUT must comply with the requirements of the following standards:

- ♦ EN 300 328 V2.2.2 (2019-07)

## 1.3 Testing Location Information

Test Lab. : Sporton International Inc. Hsinhua Laboratory				
<input checked="" type="checkbox"/> Hsinhua (TAF: 3785)	ADD: No.52, Huaya 1st Rd., Guishan Dist., Taoyuan City 333411, Taiwan (R.O.C.)			
	TEL: 886-3-327-3456	FAX: 886-3-327-0973		
Test Condition	Test Site No.	Test Engineer	Test Environment	Test Date
RF Conducted	TH06-HY	Jin	22.6~26.4°C / 51~57%	07/Nov/2022
Radiated	05CH01-HY	Wayne	21.6~22.1°C / 52~57%	15/Oct/2022~18/Oct/2022
Adaptivity	DFS01-HY	Wayne	20~26.5°C / 51~59%	04/Nov/2022
Receiver Blocking	DFS01-HY	Wayne	21~24.3°C / 56~58%	04/Nov/2022
<input type="checkbox"/> Wen 33rd.St. (TAF: 3785)	ADD: No.14-1, Ln. 19, Wen 33rd St., Guishan Dist., Taoyuan City 333010, Taiwan (R.O.C.)			
	TEL: 886-3-318-0787	FAX: 886-3-318-0287		

## 1.4 Measurement Uncertainty

ISO/IEC 17025 requires that an estimate of the measurement uncertainties associated with the emissions test results be included in the report. The measurement uncertainties given below are based on a 95% confidence level (based on a coverage factor (k=2))

Parameter	Uncertainty	Remark
RF Output Power	1.2 dB	Confidence levels of 95%
Power Spectral Density	1.2 dB	Confidence levels of 95%
Duty cycle, Tx-sequence, Tx-gap	1 %	Confidence levels of 95%
Adaptivity	1 %	Confidence levels of 95%
Occupied Channel Bandwidth	0.05 MHz	Confidence levels of 95%
Receiver Blocking	1 %	Confidence levels of 95%
Radiated Spurious Emissions	4.8 dB	Confidence levels of 95%



## 2 Test Configuration of EUT

### 2.1 Test Condition

Condition Item	Abbreviation/Remark	Remark
Tnom	Tnom	20°C
Tmin	Tmin	0°C
Tmax	Tmax	40°C
-	Vnom	230V



### 2.2 Test Channel Mode

Test Software Version	EspRFTTestTool_v2.9
-----------------------	---------------------

Mode	Power Setting
802.11b_Nss1,(1Mbps)_1TX	-
2412MHz	15
2442MHz	16
2472MHz	16
802.11g_Nss1,(6Mbps)_1TX	-
2412MHz	13
2442MHz	13
2472MHz	14
802.11n HT20_Nss1,(MCS0)_1TX	-
2412MHz	8
2442MHz	9
2472MHz	10
802.11n HT40_Nss1,(MCS0)_1TX	-
2422MHz	9
2442MHz	8
2462MHz	9

### 2.3 The Worst Case Measurement Configuration

The Worst Case Mode for Following Conformance Tests	
<b>Test Items</b>	RF Output Power, Power Spectral Density, Occupied Channel Bandwidth, Transmitter unwanted emissions in the OOB domain
<b>Test Condition</b>	Conducted measurement at transmit chains

The Worst Case Mode for Following Conformance Tests			
<b>Test Item</b>	Transmitter Unwanted Emissions in The Spurious Domain Receiver Spurious Emissions		
<b>Test Condition</b>	Radiated measurement		
<b>Operating Mode</b>	Transmit / Receive		
<b>1</b>	Adapter mode		
<b>Orthogonal Planes of EUT</b>	<b>X Plane</b>	<b>Y Plane</b>	<b>Z Plane</b>
			
<b>Worst Planes of EUT</b>		V	

The Worst Case Mode for Following Conformance Tests	
<b>Test Items</b>	Adaptivity
<b>Test Condition</b>	Conducted measurement at transmit chains

The Worst Case Mode for Following Conformance Tests	
<b>Test Items</b>	Receiver Blocking
<b>Test Condition</b>	Conducted measurement at a receiver chain

## 2.4 Accessories

Accessories				
AC Adapter	Brand Name	PHILIPS	Model Name	S024CSM1200200
	Power Rating	I/P: 100-240Vac, 0.6A, O/P: 12.0Vdc, 2.0A		
	Power Cord	1.25 meter, non-shielded cable, w/o ferrite core		
HDMI Cable	Signal Line	1.0 meter, shielded cable, w/o ferrite core		

Reminder: Regarding to more detail and other information, please refer to user manual.

## 2.5 Support Equipment

Support Equipment - RF Conducted				
No.	Equipment	Brand Name	Model Name	Remark
1	Notebook	HP	HSTNN-I42C	-
2	Adapter for NB	HP	HSTNN-CA40	-
3	USB Cable	CHANG YANG	E210567	-
4	CP2102 USB to UART Bridge	segger	CP2102	-

Support Equipment - Adaptivity				
No.	Equipment	Brand Name	Model Name	Remark
1	AP (Master)	Inteno	EG400	-
2	Notebook	DELL	Latitude E5570	-
3	CP2102 USB to UART Bridge	segger	CP2102	-

Support Equipment - Receiver Blocking				
No.	Equipment	Brand Name	Model Name	Remark
1	Shielding Box	H.C.E	G2424F-D	-
2	Notebook	DELL	Latitude E5570	-
3	CP2102 USB to UART Bridge	segger	CP2102	-

## 2.6 Test Setup Diagram

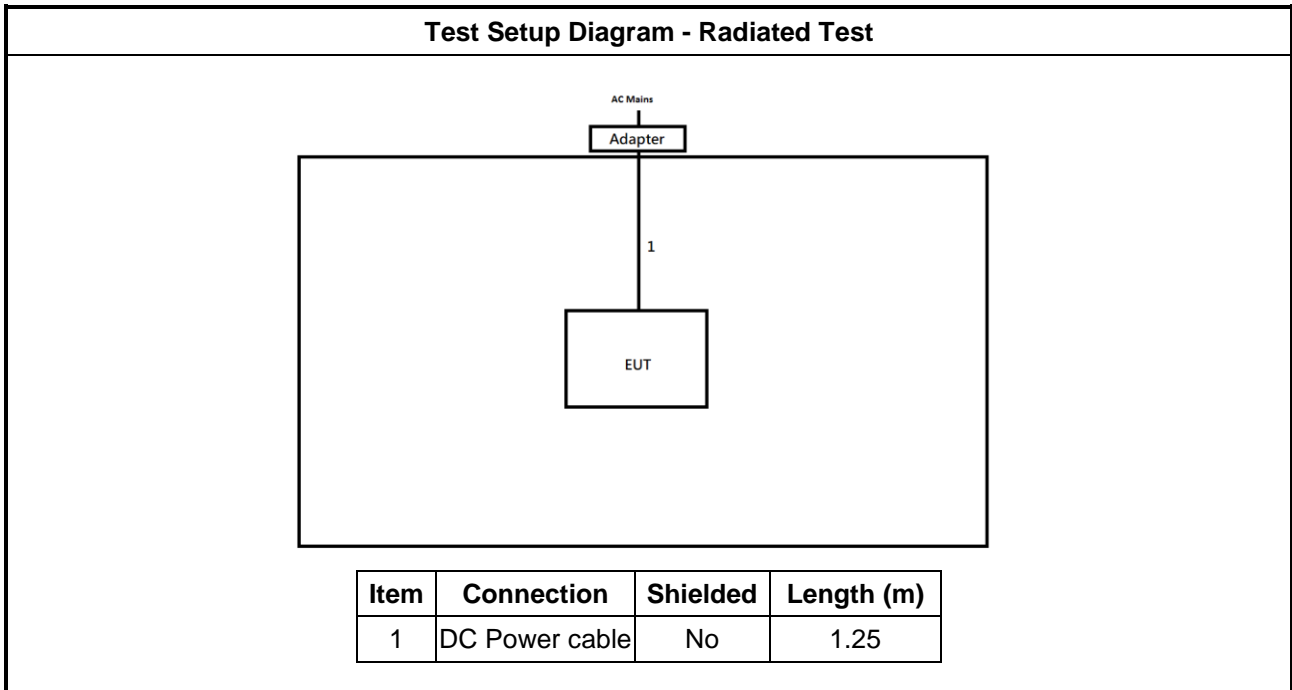

### 3 Transmitter Test Result

#### 3.1 RF Output Power

##### 3.1.1 RF Output Power Limit

RF Output Power Limit
<input checked="" type="checkbox"/> Mean equivalent isotropic radiated power (e.i.r.p.) ≤ 20 dBm

##### 3.1.2 Measuring Instruments

Refer a test equipment and calibration data table in this test report.

##### 3.1.3 Test Procedures

Test Method
<input checked="" type="checkbox"/> The measurements shall be performed at both normal environmental conditions and at the extremes of the operating temperature range.
<input checked="" type="checkbox"/> Refer as EN 300 328, clause 5.4.2.2.1 for conducted measurement.
<p>Step 1: Use a fast power sensor suitable for 2,4 GHz and capable of 1 MS/s.            Use the following settings:</p> <ul style="list-style-type: none"> <li>- Sample speed 1 MS/s or faster.</li> <li>- The samples shall represent the RMS power of the signal.</li> <li>- Measurement duration: For adaptive equipment, the measurement duration shall be long enough to ensure a minimum number of bursts (at least 10) are captured.</li> </ul> <p>NOTE 1: For adaptive equipment, to increase the measurement accuracy, a higher number of bursts may be used.</p> <p>Step 2: For conducted measurements on devices with multiple transmit chains:</p> <ul style="list-style-type: none"> <li>- Connect one power sensor to each transmit port for a synchronous measurement on all transmit ports.</li> <li>- Trigger the power sensors so that they start sampling at the same time.              Make sure the time difference between the samples of all sensors is less than half the time between the samples of all sensors is less than 500 ns.</li> <li>- For each instant in time, sum the power of the individual samples of all ports and store them. Use these stored samples in all following steps.</li> </ul> <p>Step 3: Find the start and stop times of each burst in the stored measurement samples.            NOTE 2: The start and stop times are defined as the points where the power is at least 30 dB the RMS burst power calculated in step 4.</p> <p>Step 4: Between the start and stop times of each individual burst calculate the RMS power over the burst using the formula below. Save these Pburst values, as well as the start and stop times for each burst.</p> $P_{burst} = \frac{1}{k} \sum_{n=1}^k P_{sample}(n)$ <p style="text-align: center;">with 'k' being the total number of samples and 'n' the actual sample number</p> <p>Step 5: The highest of all Pburst values (value "A" in dBm) will be used for maximum e.i.r.p. calculations.</p>

Step 6: Add the (stated) antenna assembly gain "G" in dBi of the individual antenna.  
 If applicable, add the additional beamforming gain "Y" in dB.  
 If more than one antenna assembly is intended for this power setting, the maximum overall antenna gain (G or G + Y) shall be used. The RF Output Power (P) shall be calculated using the formula below:  
 $P = A + G + Y$ . This value, which shall comply with the limit given in clauses 4.3.2.2.3, shall be recorded in the test report.

Refer as EN 300 328, clause 5.4.2.2.2 for radiated measurement.

**3.1.4 Test Setup**

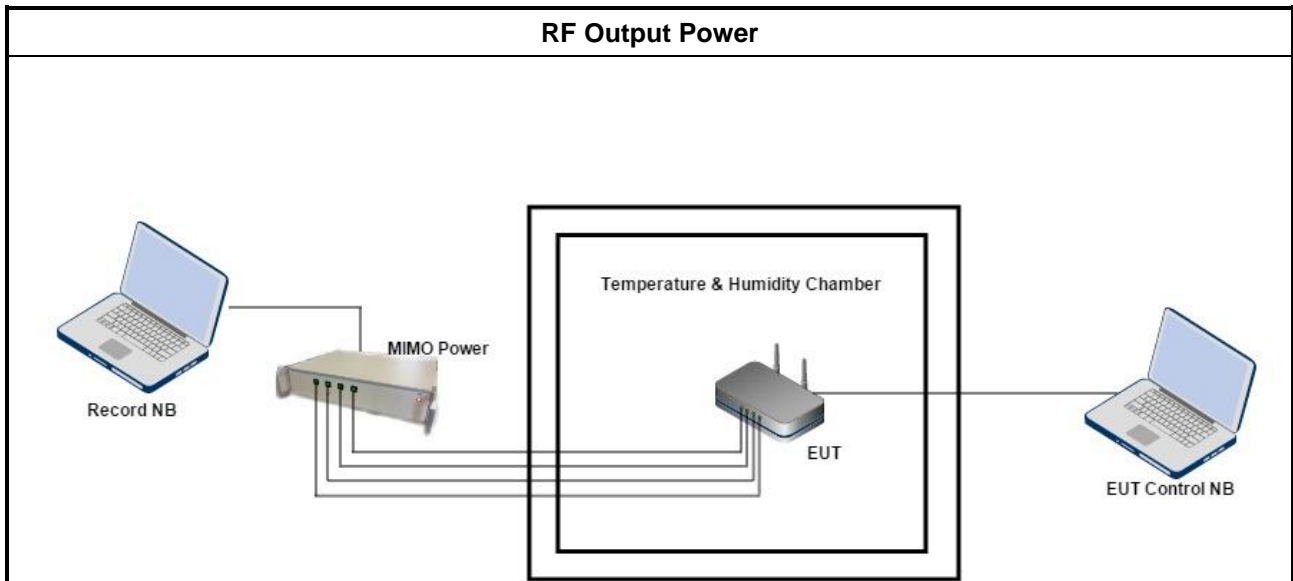

Test conditions:  
 The measurements for RF output power shall be performed at both normal environmental conditions and at the extremes of the operating temperature range.

**3.1.5 Test Result of RF Output Power**

Refer as Appendix A

### 3.2 Power Spectral Density

#### 3.2.1 Power Spectral Density Limit

Power Spectral Density Limit	
<input checked="" type="checkbox"/>	Mean equivalent isotropic radiated power (e.i.r.p.) density $\leq 10$ dBm/MHz

#### 3.2.2 Measuring Instruments

Refer a test equipment and calibration data table in this test report.

#### 3.2.3 Test Procedures

Test Method	
<input checked="" type="checkbox"/>	Power spectral density shall be measured using one of the options below.
<input type="checkbox"/>	Option 1: For equipment with continuous and non-continuous transmissions. Refer as EN 300 328, clause 5.4.3.2.1.
<input checked="" type="checkbox"/>	Option 2: For equipment with continuous transmission capability or for equipment operating (or with the capability to operate) with a constant duty cycle (e.g. Frame Based equipment). Refer as EN 300 328, clause 5.4.3.2.1.
<input checked="" type="checkbox"/>	Refer as EN 300 328, clause 5.4.3.2.1 for conducted measurement.
<input type="checkbox"/>	Option 1:
Step 1:	Connect the UUT to the spectrum analyzer and use the following settings: <ul style="list-style-type: none"> <li>- Start &amp; Stop Frequency: 2400 MHz ~ 2483.5MHz</li> <li>- Resolution BW: 10 kHz</li> <li>- Video BW: 30 kHz</li> <li>- Sweep Points: &gt; 8 350</li> <li>- Detector Mode: RMS</li> <li>- Trace Mode: Max Hold</li> <li>- Sweep time:               <ul style="list-style-type: none"> <li>For non-continuous transmissions: 2 x Channel Occupancy Time x number of sweep points</li> <li>For continuous transmissions: 10s; the sweep time may be increased further until a value where the sweep time has no impact on the RMS value of the signal</li> <li>For non-continuous signals, wait for the trace to stabilize.</li> </ul> </li> </ul>
Step 2:	For conducted measurements on smart antenna systems using either operating mode 2 or operating mode 3 (see clause 5.3.2.2), repeat the measurement for each of the transmit ports. For each sampling point (frequency domain), add up the coincident power values (in mW) for the different transmit chains and use this as the new data set.
Step 3:	Add up the values for power for all the samples in the file using the formula below. $P_{Sum} = \sum_{n=1}^k P_{sample}(n)$ with 'k' being the total number of samples and 'n' the actual sample number
Step 4:	Normalize the individual values for power (in dBm) so that the sum is equal to the RF Output Power (e.i.r.p.) measured in clause 5.4.2 and save the corrected data. The following formulas can be used: $C_{Corr} = P_{Sum} - P_{e.i.r.p.}$ $P_{Samplecorr}(n) = P_{Sample}(n) - C_{Corr}$ with 'n' being the actual sample number

Step 5:	Starting from the first sample $P_{\text{Samplecorr}}(n)$ (lowest frequency), add up the power (in mW) of the following samples representing a 1 MHz segment and record the results for power and position (i.e. sample #1 to sample #100). This is the Power Spectral Density (e.i.r.p.) for the first 1 MHz segment which shall be recorded.
Step 6:	Shift the start point of the samples added up in step 5 by one sample and repeat the procedure in step 5 (i.e. sample #2 to #101).
Step 7:	Repeat step 6 until the end of the data set and record the Power Spectral Density values for each of the 1 MHz segments. From all the recorded results, the highest value is the maximum Power Spectral Density for the UUT. This value, which shall comply with the limit given in clause 4.3.2.3.3, shall be recorded in the test report.
<input checked="" type="checkbox"/> Option 2:	
Step 1:	Connect the UUT to the spectrum analyser and use the following settings: <ul style="list-style-type: none"> <li>- Centre Frequency: The centre frequency of the channel under test</li> <li>- RBW: 1 MHz</li> <li>- VBW: 3 MHz</li> <li>- Frequency Span: 2 x Nominal Bandwidth (e.g. 40 MHz for a 20 MHz channel)</li> <li>- Detector Mode: Peak</li> <li>- Trace Mode: Max Hold</li> </ul>
Step 2:	When the trace is complete, find the peak value of the power envelope and record the frequency.
Step 3:	Make the following changes to the settings of the spectrum analyser: <ul style="list-style-type: none"> <li>- Centre Frequency: Equal to the frequency recorded in step 2</li> <li>- Frequency Span: 3 MHz</li> <li>- RBW: 1 MHz</li> <li>- VBW: 3 MHz</li> <li>- Sweep Time: 1 minute</li> <li>- Detector Mode: RMS</li> <li>- Trace Mode: Max Hold</li> </ul>
Step 4:	When the trace is complete, the trace shall be captured using the "Hold" or "View" option on the spectrum analyser. Find the peak value of the trace and place the analyser marker on this peak. This level is recorded as the highest mean power (power spectral density) $D$ in a 1 MHz band. Alternatively, where a spectrum analyser is equipped with a function to measure power spectral density, this function may be used to display the power spectral density $D$ in dBm / MHz. In case of conducted measurements on smart antenna systems operating in a mode with multiple transmit chains active simultaneously, the power spectral density of each transmit chain shall be measured separately to calculate the total power spectral density (value $D$ in dBm / MHz) for the UUT.
Step 5:	The maximum Power Spectral Density (PSD) e.i.r.p. is calculated from the above measured power spectral density $D$ , the observed Duty Cycle (DC) (see clause 5.4.2.2.1.3, step 4), the applicable antenna assembly gain $G$ in dBi and if applicable the beamforming gain $Y$ in dB, according to the formula below. This value shall be recorded in the test report. If more than one antenna assembly is intended for this power setting, the gain of the antenna assembly with the highest gain shall be used. $PSD = D + G + Y + 10 \times \log(1 / DC)$ (dBm / MHz)
<input type="checkbox"/> Refer as EN 300 328, clause 5.4.3.2.2 for radiated measurement.	

### 3.2.4 Test Setup

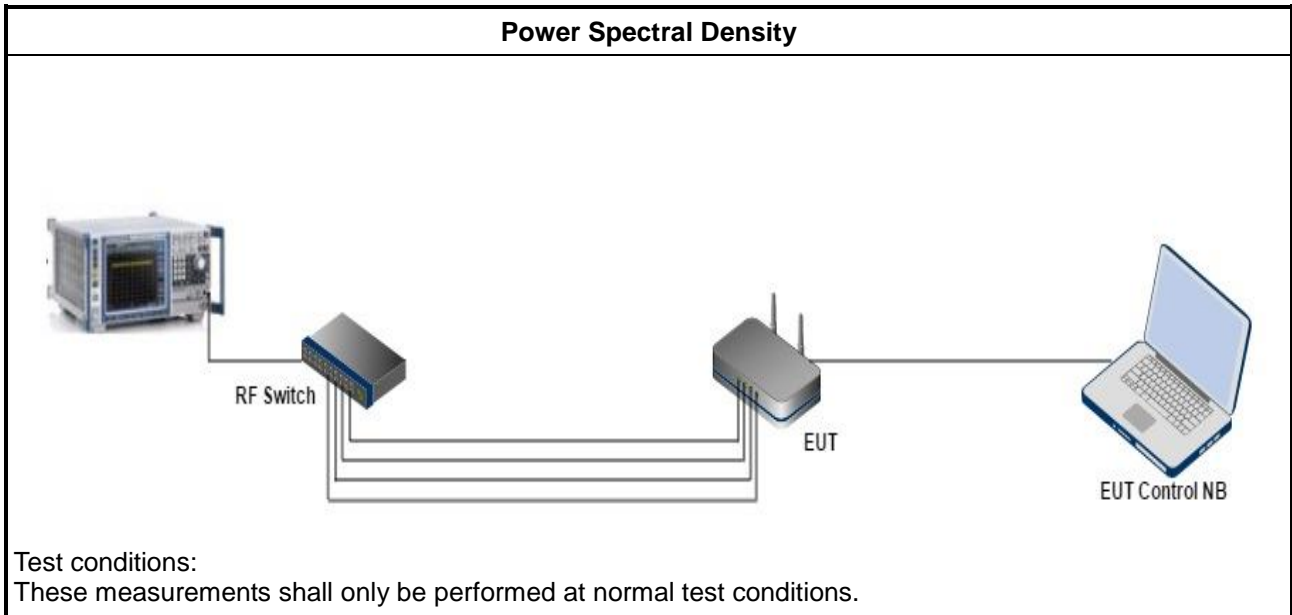

### 3.2.5 Test Result of Power Spectral Density

Refer as Appendix B

### 3.3 Occupied Channel Bandwidth

#### 3.3.1 Occupied Channel Bandwidth Limit

Occupied Channel Bandwidth Limit
<b>Type of Frequency Hopping Equipment:</b>
<input type="checkbox"/> Occupied Channel Bandwidth for each hopping frequency fall completely within 2.4 GHz – 2.4835 GHz.
<input type="checkbox"/> For non-adaptive equipment with e.i.r.p greater than 10 dBm, Occupied Channel Bandwidth $\leq$ 5 MHz.
<b>Type of Equipment Using Wide Band Modulations Other than FHSS:</b>
<input checked="" type="checkbox"/> Occupied Channel Bandwidth fall completely within 2.4 GHz – 2.4835 GHz.
<input type="checkbox"/> For non-adaptive equipment with e.i.r.p greater than 10 dBm, Occupied Channel Bandwidth $\leq$ 20 MHz.

#### 3.3.2 Measuring Instruments

Refer a test equipment and calibration data table in this test report.

#### 3.3.3 Test Procedures

Test Method
<input checked="" type="checkbox"/> Refer as EN 300 328, clause 5.4.7.2.1 for conducted measurement.
<p>Step 1: Connect the UUT to the spectrum analyzer and use the following settings:</p> <ul style="list-style-type: none"> <li>- Centre Frequency : The centre frequency of the channel under test.</li> <li>- Resolution BW : <math>\sim</math> 1 % of the span without going below 1 %.</li> <li>- Video BW : 3 <math>\times</math> RBW.</li> <li>- Frequency Span : 2 <math>\times</math> Occupied Channel Bandwidth (e.g. 40 MHz for a 20 MHz channel)</li> <li>- Detector Mode : RMS.</li> <li>- Trace Mode : Max Hold.</li> <li>- Sweep Time : 1s.</li> </ul> <p>Step 2: Wait until the trace is completed. Find the peak value of the trace and place the analyzer marker on this peak.</p> <p>Step 3: Use the 99 % bandwidth function of the spectrum analyzer to measure the Occupied Channel Bandwidth of the UUT ,This value shall be recorded. NOTE: Make sure that the power envelope is sufficiently above the noise floor of the analyzer to avoid the noise signals left and right from the power envelope being taken into account by this measurement.</p>
<input type="checkbox"/> Refer as EN 300 328, clause 5.4.7.2.2 for radiated measurement.

### 3.3.4 Test Setup

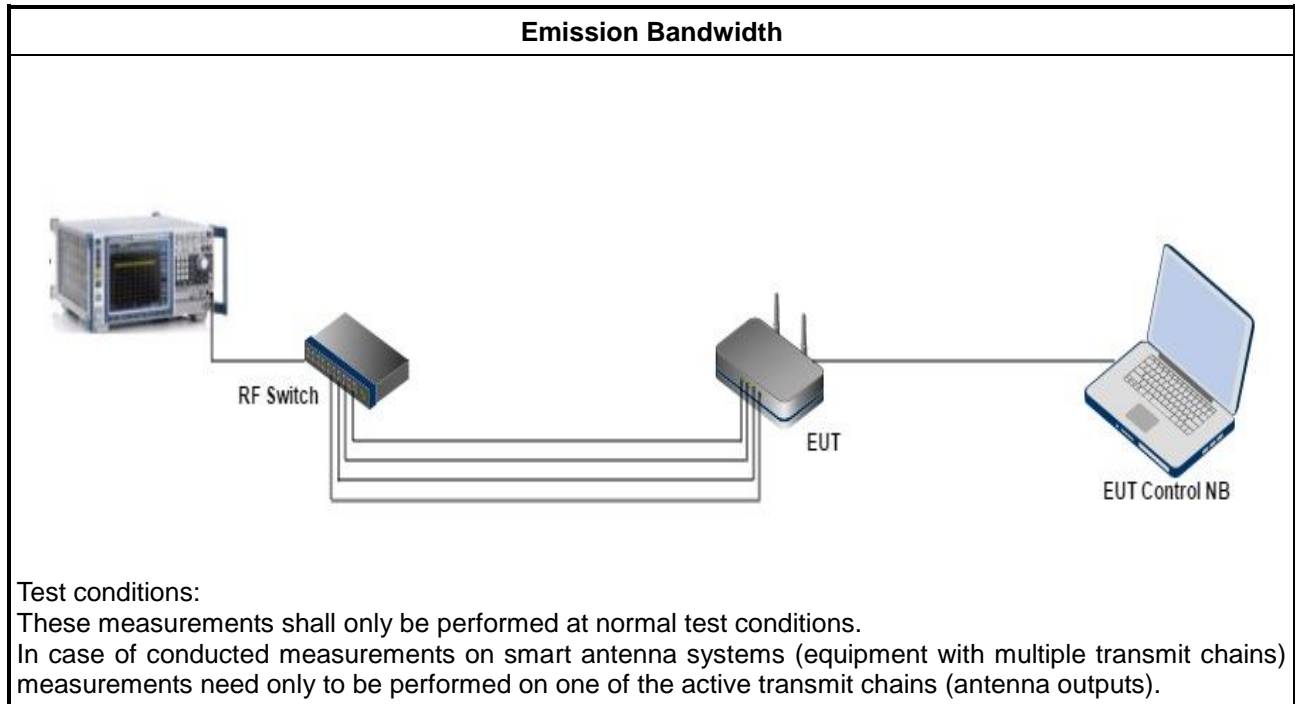

### 3.3.5 Test Result of Occupied Channel Bandwidth

Refer as Appendix C

### 3.4 Transmitter Unwanted Emissions in the Out-of-band Domain

#### 3.4.1 Transmitter Unwanted Emissions in the Out-of-band Domain Limit

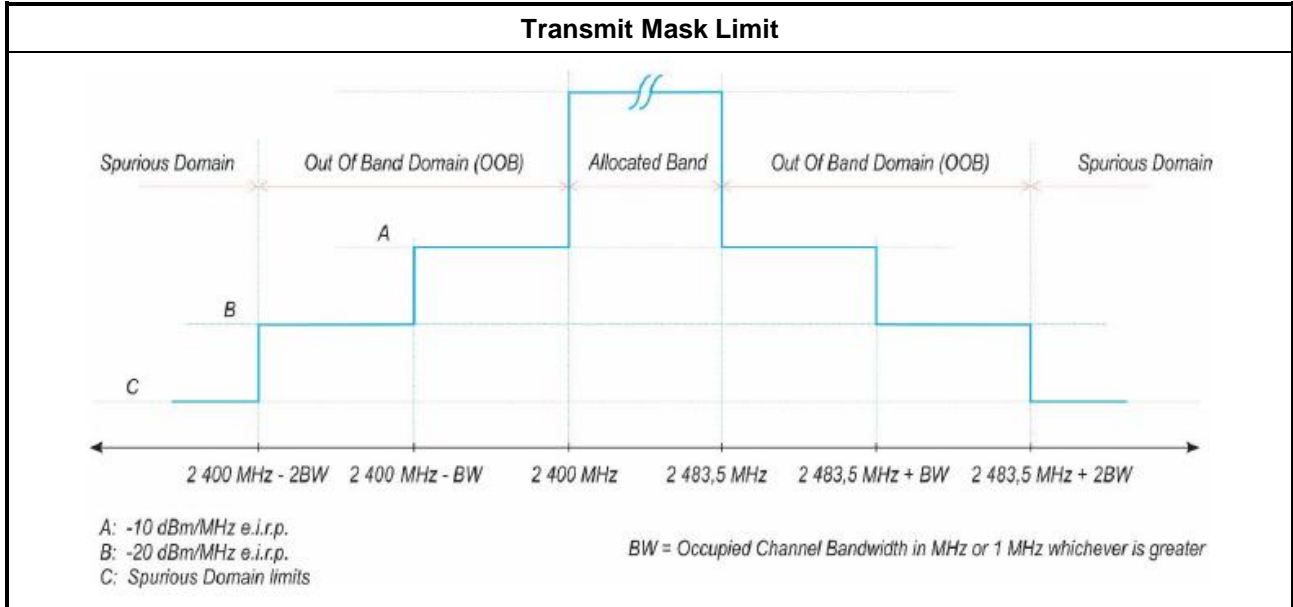

#### 3.4.2 Measuring Instruments

Refer a test equipment and calibration data table in this test report.

#### 3.4.3 Test Procedures

Test Method
<input checked="" type="checkbox"/> Refer as EN 300 328, clause 5.4.8.2.1 for conducted measurement.
Step 1: Connect the UUT to the spectrum analyzer and use the following settings: <ul style="list-style-type: none"> <li>- Centre Frequency : 2 484 MHz</li> <li>- Span : 0 Hz</li> <li>- Resolution BW : 1 MHz</li> <li>- Filter mode : Channel filter</li> <li>- Video BW : 3MHz</li> <li>- Detector Mode : RMS</li> <li>- Trace Mode : Clear / Write</li> <li>- Sweep Mode : Continuous</li> <li>- Sweep Points : Sweep Time [s] / (1 μs) or 5 000 whichever is greater</li> <li>- Trigger Mode : Video trigger</li> <li>- Sweep Time : &gt; 120 % of the duration of the longest burst detected during the measurement of the RF Output Power.</li> </ul> NOTE 1: In case video triggering is not possible, an external trigger source may be used.

Step 2: (segment 2 483,5 MHz to 2 483,5 MHz + BW)

- Adjust the trigger level to select the transmissions with the highest power level.
- For frequency hopping equipment operating in a normal hopping mode, the different hops will result in signal bursts with different power levels. In this case the burst with the highest power level shall be selected.
- Set a window (start and stop lines) to match with the start and end of the burst and in which the RMS power shall be measured using the Time Domain Power function.
- Select RMS power to be measured within the selected window and note the result which is the RMS power within this 1 MHz segment (2 483,5 MHz to 2 484,5 MHz). Compare this value with the applicable limit provided by the mask.
- Increase the centre frequency in steps of 1 MHz and repeat this measurement for every 1 MHz segment within the range 2 483,5 MHz to 2 483,5 MHz + BW. The centre frequency of the last 1 MHz segment shall be set to 2 483,5 MHz + BW - 0,5 MHz (which means this may partly overlap with the previous 1 MHz segment).

Step 3: (segment 2 483,5 MHz + BW to 2 483,5 MHz + 2BW)

- Change the centre frequency of the analyzer to 2 484 MHz + BW and perform the measurement for the first 1 MHz segment within range 2 483,5 MHz + BW to 2 483,5 MHz + 2BW. Increase the centre frequency in 1 MHz steps and repeat the measurements to cover this whole range. The centre frequency of the last 1 MHz segment shall be set to 2 483,5 MHz + 2 BW - 0,5 MHz.

Step 4: (segment 2 400 MHz - BW to 2 400 MHz)

- Change the centre frequency of the analyzer to 2 399,5 MHz and perform the measurement for the first 1 MHz segment within range 2 400 MHz - BW to 2 400 MHz. Reduce the centre frequency in 1 MHz steps and repeat the measurements to cover this whole range. The centre frequency of the last 1 MHz segment shall be set to 2 400 MHz - 2BW + 0,5 MHz.

Step 5: (segment 2 400 MHz - 2BW to 2 400 MHz - BW)

- Change the centre frequency of the analyzer to 2 399,5 MHz - BW and perform the measurement for the first 1 MHz segment within range 2 400 MHz - 2BW to 2 400 MHz - BW. Reduce the centre frequency in 1 MHz steps and repeat the measurements to cover this whole range. The centre frequency of the last 1 MHz segment shall be set to 2 400 MHz - 2BW + 0,5 MHz.

Step 6: - In case of conducted measurements on equipment with a single transmit chain, the declared antenna assembly gain "G" in dBi shall be added to the results for each of the 1 MHz segments and compared with the limits provided by the mask given in figures 1 or 3. If more than one antenna assembly is intended for this power setting, the antenna with the highest gain shall be considered.

- In case of conducted measurements on smart antenna systems (equipment with multiple transmit chains), the measurements need to be repeated for each of the active transmit chains. The declared antenna assembly gain "G" in dBi for a single antenna shall be added to these results. If more than one antenna assembly is intended for this power setting, the antenna with the highest gain shall be considered. Comparison with the applicable limits shall be done using any of the options given below:

- Option 1: the results for each of the transmit chains for the corresponding 1 MHz segments shall be added. The additional beamforming gain "Y" in dB shall be added as well and the resulting values compared with the limits provided by the mask given in figures 1 or 3.

- Option 2: the limits provided by the mask given in figures 1 or 3 shall be reduced by  $10 \times \log_{10}(Ach)$  and the additional beamforming gain "Y" in dB. The results for each of the transmit chains shall be individually compared with these reduced limits.

NOTE 2: Ach refers to the number of active transmit chains. It shall be recorded whether the equipment complies with the mask provided in figures 1 or 3.

Refer as EN 300 328, clause 5.4.8.2.2 for radiated measurement.

### 3.4.4 Test Setup

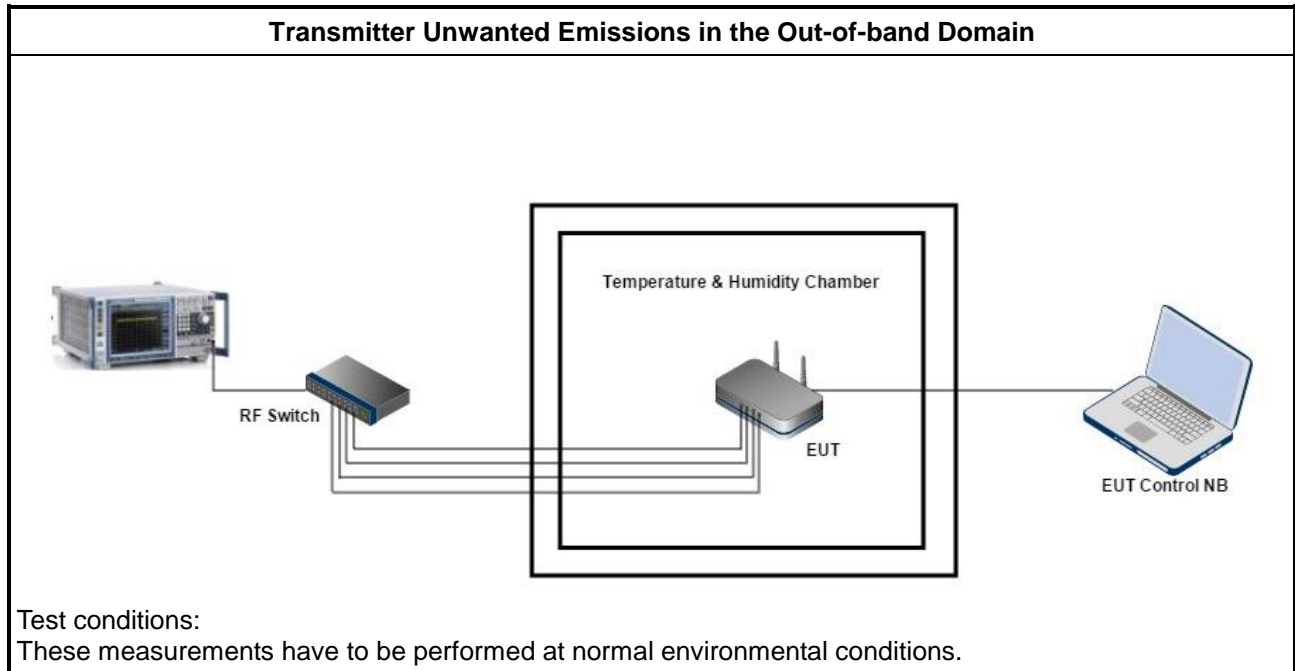

### 3.4.5 Test Result of Transmitter Unwanted Emissions in the Out-of-band Domain

Refer as Appendix D

### 3.5 Transmitter Unwanted Emissions in the Spurious Domain

#### 3.5.1 Transmitter Unwanted Emissions in the Spurious Domain Limit

Frequency Range	Maximum Power	Bandwidth
30 MHz to 47 MHz	-36 dBm	100 kHz
47 MHz to 74 MHz	-54 dBm	100 kHz
74 MHz to 87,5 MHz	-36 dBm	100 kHz
87,5 MHz to 118 MHz	-54 dBm	100 kHz
118 MHz to 174 MHz	-36 dBm	100 kHz
174 MHz to 230 MHz	-54 dBm	100 kHz
230 MHz to 470 MHz	-36 dBm	100 kHz
470 MHz to 694 MHz	-54 dBm	100 kHz
694 MHz to 1 GHz	-36 dBm	100 kHz
1 GHz to 12,75 GHz	-30 dBm	1 MHz

Note 1: spurious domain  $\leq (2400 \text{ MHz} - 2N)$  and spurious domain  $\geq (2483.5 \text{ MHz} + 2N)$ ;  
 $N = \text{MAX}(1, \text{Occupied Channel Bandwidth}) \text{ MHz}$

#### 3.5.2 Measuring Instruments

Refer a test equipment and calibration data table in this test report.

**3.5.3 Test Procedures**

<b>Test Method</b>	
<input type="checkbox"/>	Refer as EN 300 328, clause 5.4.9.2.1 for conducted measurement. Conducted spurious emissions and radiated by the cabinet with the antenna connector(s) terminated by a specified load (cabinet radiation).
<input checked="" type="checkbox"/>	Refer as EN 300 328, clause 5.4.9.2.2 for radiated measurement.
<p>Pre-scan: The test procedure below shall be used to identify potential unwanted emissions of the UUT.</p> <p>Step 1: The sensitivity of the spectrum analyzer should be such that the noise floor is at least 12 dB below the limits given in tables 4 or 12.</p> <p>Step 2: The emissions over the range 30 MHz to 1 000 MHz shall be identified.            Spectrum analyzer settings :            - Resolution bandwidth : 100 kHz            - Video bandwidth : 300 kHz            - Detector mode : Peak            - Filter type : 3 dB (Gaussian)            - Trace Mode : Max Hold            - Sweep Points : ≥ 19 400            NOTE 1: For spectrum analyzers not supporting this high number of sweep points, the frequency band may need to be segmented.            - Sweep time:            •For non-continuous transmissions (duty cycle less than 100 %), the sweep time shall be sufficiently long, such that for each 100 kHz frequency step, the measurement time is greater than two transmissions of the UUT.            •For Frequency Hopping equipment operating in a normal operating (hopping not disabled) mode, the sweep time shall be further increased to capture multiple transmissions on the same hopping frequency in different hopping sequences.            Allow the trace to stabilize. Any emissions identified during the sweeps above and that fall within the 6 dB range below the applicable limit or above, shall be individually measured using the procedure in clause 5.4.9.2.1.3 and compared to the limits given in tables 4 or 12.</p> <p>Step 3: The emissions over the range 1 GHz to 12,75 GHz shall be identified.            Spectrum analyzer settings:            - Resolution bandwidth : 1 MHz            - Video bandwidth : 3 MHz            - Filter type : 3 dB (Gaussian)            - Detector mode : Peak            - Trace Mode : Max Hold            - Sweep Points : ≥ 23 500            NOTE 2: For spectrum analyzers not supporting this high number of sweep points, the frequency band may need to be segmented.            - Sweep time:            •For non-continuous transmissions (duty cycle less than 100 %), the sweep time shall be sufficiently long, such that for each 1 MHz frequency step, the measurement time is greater than two transmissions of the UUT.            •For Frequency Hopping equipment operating in a normal operating (hopping not disabled) mode, the sweep time shall be further increased to capture multiple transmissions on the same hopping frequency in different hopping sequences.            Allow the trace to stabilize. Any emissions identified during the sweeps above that fall within the 6 dB range below the applicable limit or above, shall be individually measured using the procedure in clause 5.4.9.2.1.3 and compared to the limits given in tables 4 or 12.            Frequency Hopping equipment may generate a block (or several blocks) of spurious emissions anywhere within the spurious domain. If this is the case, only the highest peak of each block of emissions shall be measured using the procedure in clause 5.4.9.2.1.3.</p>	

Step 4: In case of conducted measurements on smart antenna systems (equipment with multiple transmit chains), the steps 2 and 3 need to be repeated for each of the active transmit chains (Ach). The limits used to identify emissions during this pre-scan need to be reduced with  $10 \times \log_{10}(\text{Ach})$  (number of active transmit chains).

Measurement of the emissions identified during the pre-scan

Step 1: The level of the emissions shall be measured using the following spectrum analyzer settings:

- Measurement Mode : Time Domain Power
- Centre Frequency : Frequency of emission identified during the pre-scan
- Resolution Bandwidth : 100 kHz (< 1 GHz) / 1 MHz (> 1 GHz)
- Video Bandwidth : 300 kHz (< 1 GHz) / 3 MHz (> 1 GHz)
- Frequency Span : Zero Span
- Sweep mode : Single Sweep
- Sweep time : >120 % of the duration of the longest burst detected during the measurement of the RF Output Power
- Sweep points : Sweep time [ $\mu\text{s}$ ] / (1  $\mu\text{s}$ ) with a maximum of 30 000
- Trigger : Video (burst signals) or Manual (continuous signals)
- Detector : RMS

Step 2: Set a window where the start and stop indicators match the start and end of the burst with the highest level and record the value of the power measured within this window. If the spurious emission to be measured is a continuous transmission, the measurement window shall be set to match the start and stop times of the sweep.

Step 3: In case of conducted measurements on smart antenna systems (equipment with multiple transmit chains), step 2 needs to be repeated for each of the active transmit chains (Ach). Sum the measured power (within the observed window) for each of the active transmit chains.

Step 4: The value defined in step 3 shall be compared to the limits defined in tables 4 or 12.

### 3.5.4 Test Setup

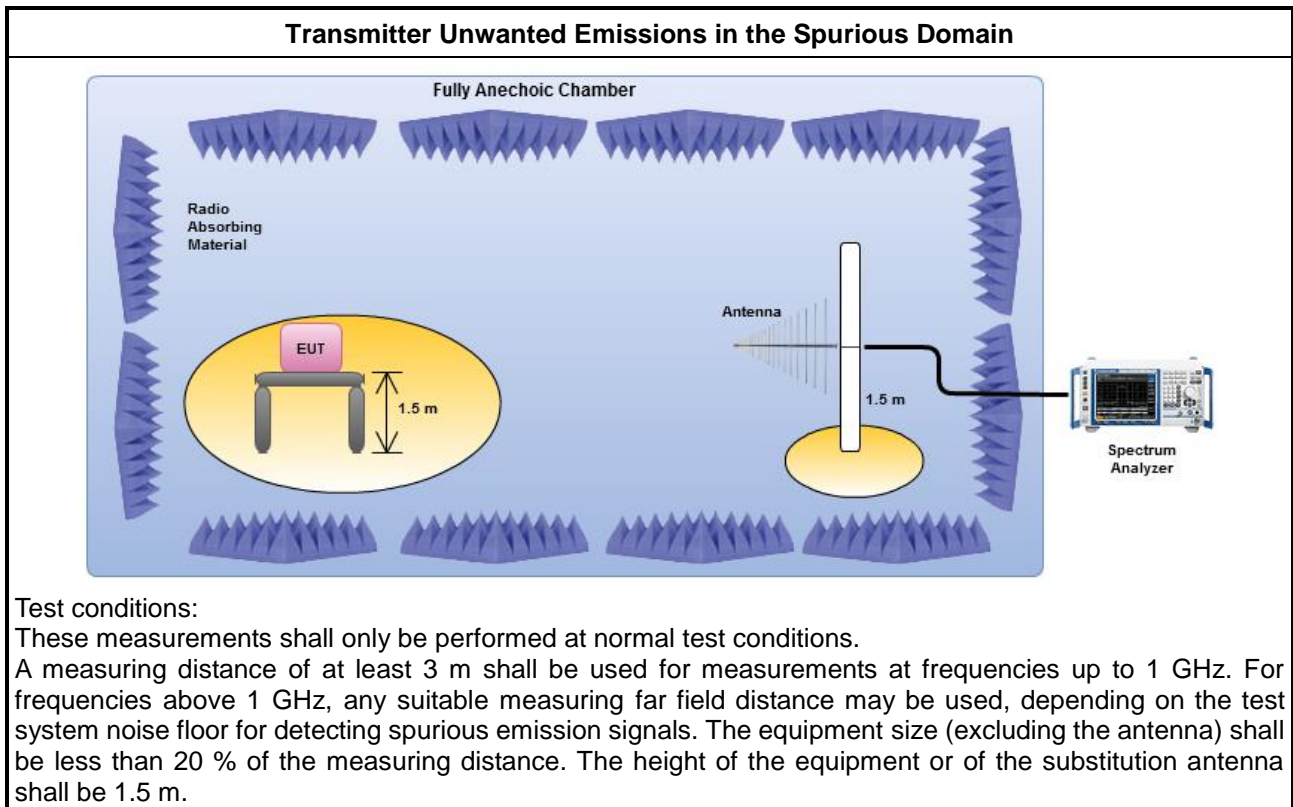



### **3.5.5 Transmitter Radiated Unwanted Emissions**

Refer as Appendix E

## 4 Receiver Test Result

### 4.1 Receiver Spurious Emissions

#### 4.1.1 Receiver Spurious Emissions Limit

Frequency Range	Maximum Power	Bandwidth
30 MHz to 1 GHz	-57 dBm	100 kHz
1 GHz to 12,75 GHz	-47 dBm	1 MHz

#### 4.1.2 Measuring Instruments

Refer a test equipment and calibration data table in this test report.

#### 4.1.3 Test Procedures

Test Method	
<input type="checkbox"/>	Refer as EN 300 328, clause 5.4.10.2.1 for conducted measurement. Conducted spurious emissions and radiated by the cabinet with the antenna connector(s) terminated by a specified load (cabinet radiation).
<input checked="" type="checkbox"/>	Refer as EN 300 328, clause 5.4.10.2.2 for radiated measurement.
Pre-scan: The test procedure below shall be used to identify potential unwanted emissions of the UUT.	
Step 1:	The sensitivity of the spectrum analyzer should be such that the noise floor is at least 12 dB below the limits given in tables 5 or 13.
Step 2:	The emissions over the range 30 MHz to 1 000 MHz shall be identified. Spectrum analyzer settings : - Resolution bandwidth : 100 kHz - Video bandwidth : 300 kHz - Filter type : 3 dB (Gaussian) - Detector mode : Peak - Trace Mode : Max Hold - Sweep Points : ≥ 19 400 NOTE 1: For spectrum analyzers not supporting this high number of sweep points, the frequency band may need to be segmented. - Sweep time : Auto Allow the trace to stabilize. Any emissions identified during the sweeps above and that fall within the 6 dB range below the applicable limit or above, shall be individually measured using the procedure in clause 5.4.10.2.1.3 and compared to the limits given in tables 5 or 13.

- Step 3: The emissions over the range 1 GHz to 12,75 GHz shall be identified.  
 Spectrum analyzer settings:  
 - Resolution bandwidth : 1 MHz  
 - Video bandwidth : 3 MHz  
 - Filter type : 3 dB (Gaussian)  
 - Detector mode : Peak  
 - Trace Mode : Max Hold  
 - Sweep Points :  $\geq 23\ 500$   
 NOTE 2: For spectrum analyzers not supporting this high number of sweep points, the frequency band may need to be segmented.  
 - Sweep time: Auto  
 Allow the trace to stabilize. Any emissions identified during the sweeps above that fall within the 6 dB range below the applicable limit or above, shall be individually measured using the procedure in clause 5.4.10.2.1.3 and compared to the limits given in tables 5 or 13.  
 Frequency Hopping equipment may generate a block (or several blocks) of spurious emissions anywhere within the spurious domain. If this is the case, only the highest peak of each block of emissions shall be measured using the procedure in clause 5.4.10.2.1.3.
- Step 4: In case of conducted measurements on smart antenna systems (equipment with multiple transmit chains), the steps 2 and 3 need to be repeated for each of the active transmit chains (Ach). The limits used to identify emissions during this pre-scan need to be reduced with  $10 \times \log_{10}(\text{Ach})$  (number of active transmit chains).  
 Measurement of the emissions identified during the pre-scan
- Step 1: The level of the emissions shall be measured using the following spectrum analyzer settings:  
 - Measurement Mode : Time Domain Power  
 - Centre Frequency : Frequency of emission identified during the pre-scan  
 - Resolution Bandwidth : 100 kHz (< 1 GHz) / 1 MHz (> 1 GHz)  
 - Video Bandwidth : 300 kHz (< 1 GHz) / 3 MHz (> 1 GHz)  
 - Frequency Span : Zero Span  
 - Sweep mode : Single Sweep  
 - Sweep time : 30 ms  
 - Sweep Point :  $\geq 30\ 000$   
 - Trigger : Video (for burst signals) or Manual (for continuous signals)  
 - Detector : RMS
- Step 2: Set a window where the start and stop indicators match the start and end of the burst with the highest level and record the value of the power measured within this window.  
 If the spurious emission to be measured is a continuous transmission, the measurement window shall be set to the start and stop times of the sweep.
- Step 3: In case of conducted measurements on smart antenna systems (equipment with multiple receive chains), step 2 needs to be repeated for each of the active receive chains (Ach).  
 Sum the measured power (within the observed window) for each of the active receive chains
- Step 4: The value defined in step 3 shall be compared to the limits defined in tables 5 and 13.

**4.1.4 Test Setup**

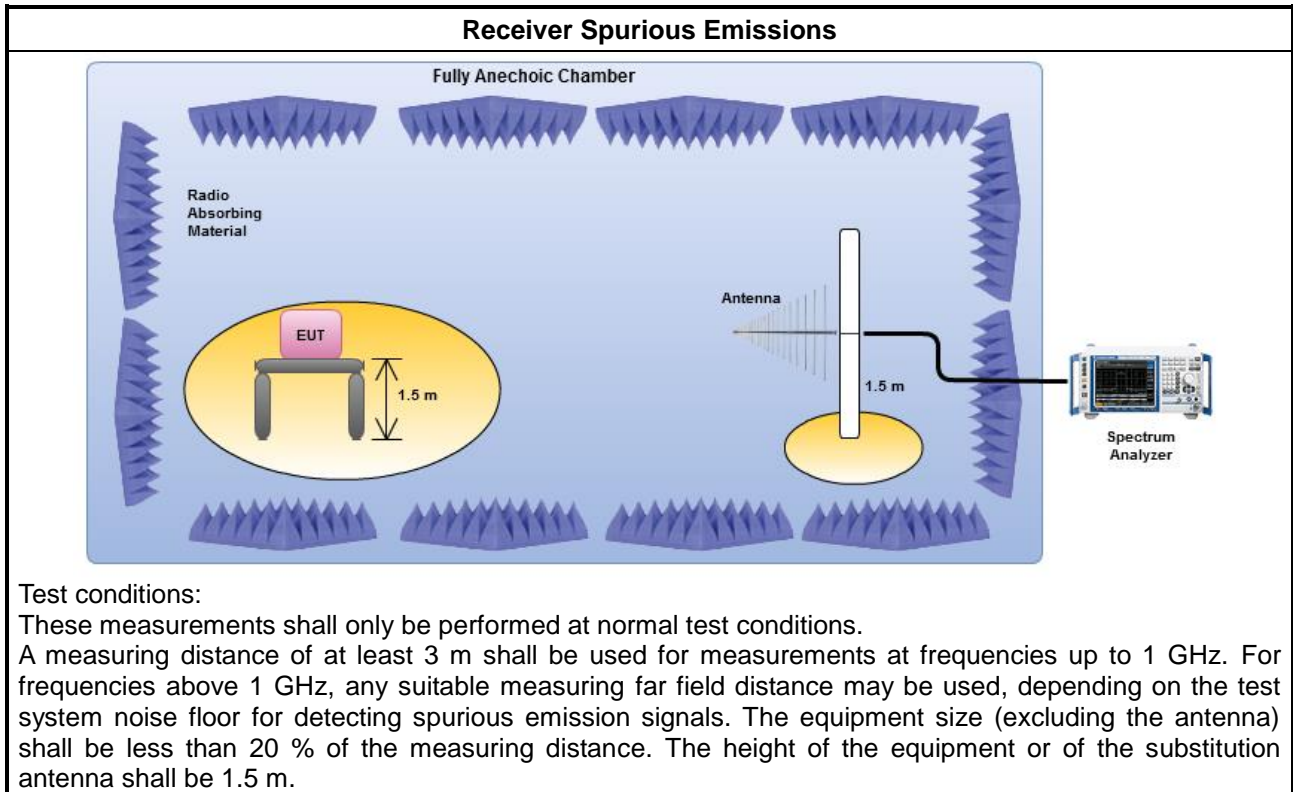

**4.1.5 Receiver Radiated Spurious Emissions**

Refer as Appendix F

## 5 Adaptivity Test Result

### 5.1 Adaptivity

#### 5.1.1 Adaptivity Limit

Adaptivity Limit	
<input checked="" type="checkbox"/>	Only for adaptive systems and RF Output Power > 10 dBm
<input type="checkbox"/>	Non-LBT based Detect and Avoid: <ul style="list-style-type: none"> <li>Minimum remain unavailable = 1sec;</li> <li>Minimum Idle Period time = 100us;</li> <li>Maximum COT = 40ms</li> <li>i.e. COT [40ms] + Idle Period [2ms - 5% of COT]; N x [COT+Idle];</li> <li>TL = -70 dBm/MHz + 10 x log10 (100 mW / Pout) (Pout in mW e.i.r.p.)</li> </ul>
<input type="checkbox"/>	LBT based Detect and Avoid (Frame Based Equipment): <ul style="list-style-type: none"> <li>Minimum Clear Channel Assessment (CCA) time &gt; 18 us;</li> <li>Maximum COT = 1 ms to 10 ms</li> <li>Minimum of Idle period Time &gt; 5% of COT</li> <li>e.g. CCA [120us] + COT [10ms] + Idle Period [0.5ms - 5% of COT];</li> <li>TL = -70 dBm/MHz + 10 x log10 (100 mW / Pout) (Pout in mW e.i.r.p.)</li> </ul>
<input checked="" type="checkbox"/>	LBT based Detect and Avoid (Load Based Equipment with spectrum sharing mechanism IEEE Std.): <ul style="list-style-type: none"> <li>LBT based spectrum sharing mechanism may implement IEEE 802.11™ [i.3], clause 10, clause 11, clause 15, clause 16, clause 18 and clause 19, or in IEEE 802.15.4™ [i.4], clause 5, clause 6 and clause 10</li> <li>TL = -70 dBm/MHz + 10 x log10 (100 mW / Pout) (Pout in mW e.i.r.p.)</li> </ul>
<input type="checkbox"/>	LBT based Detect and Avoid (Load Based Equipment): <ul style="list-style-type: none"> <li>Minimum Clear Channel Assessment (CCA) time &gt;18 us;</li> <li>Maximum COT ≤ 13ms;</li> <li>Minimum of Idle period Time &gt;18 us;</li> <li>TL = -70 dBm/MHz + 10 x log10 (100 mW / Pout) (Pout in mW e.i.r.p.)</li> </ul>
<input checked="" type="checkbox"/>	Short Control Signaling Transmissions: <ul style="list-style-type: none"> <li>Short Control Signaling Transmissions shall have a maximum duty cycle of 10 % within an observation period of 50 ms.</li> </ul>

Unwanted Signal Parameters				
Equipment Type	Wanted Signal Mean Power from Companion Device	Unwanted Signal Frequency (MHz)	Unwanted Signal Mean power (dBm)	Type of Interfering Signal
LBT	sufficient to maintain the link (see note 2)	2395 or 2488,5 (see note 1)	-35 (see note 3)	CW
Non-LBT	-30 dBm			
<p>Note 1: The highest frequency shall be used for testing operating channels within the range 2 400 MHz to 2442 MHz, while the lowest frequency shall be used for testing operating channels within the range 2 442 MHz to 2 483,5 MHz.</p> <p>Note 2: A typical value which can be used in most cases is -50 dBm/MHz.</p> <p>Note 3: The level specified is the level in front of the UUT antenna. In case of conducted measurements, this level has to be corrected by the actual antenna assembly gain.</p>				

### 5.1.2 Measuring Instruments

Refer a test equipment and calibration data table in this test report.

### 5.1.3 Test Procedures

Test Method	
<input checked="" type="checkbox"/>	Refer as EN 300 328, clause 5.4.6.2.1 for conducted measurement.
<input checked="" type="checkbox"/>	For conducted measurements on devices with multiple transmit chains and receive chains. The power splitter/combiner shall be used to combine all the transmit/receive chains (antenna outputs) into a single test point. The insertion loss of the power splitter/combiner shall be taken into account.
<input type="checkbox"/>	Refer as EN 300 328, clause 5.4.6.2.2 for radiated measurement.

### 5.1.4 Test Setup

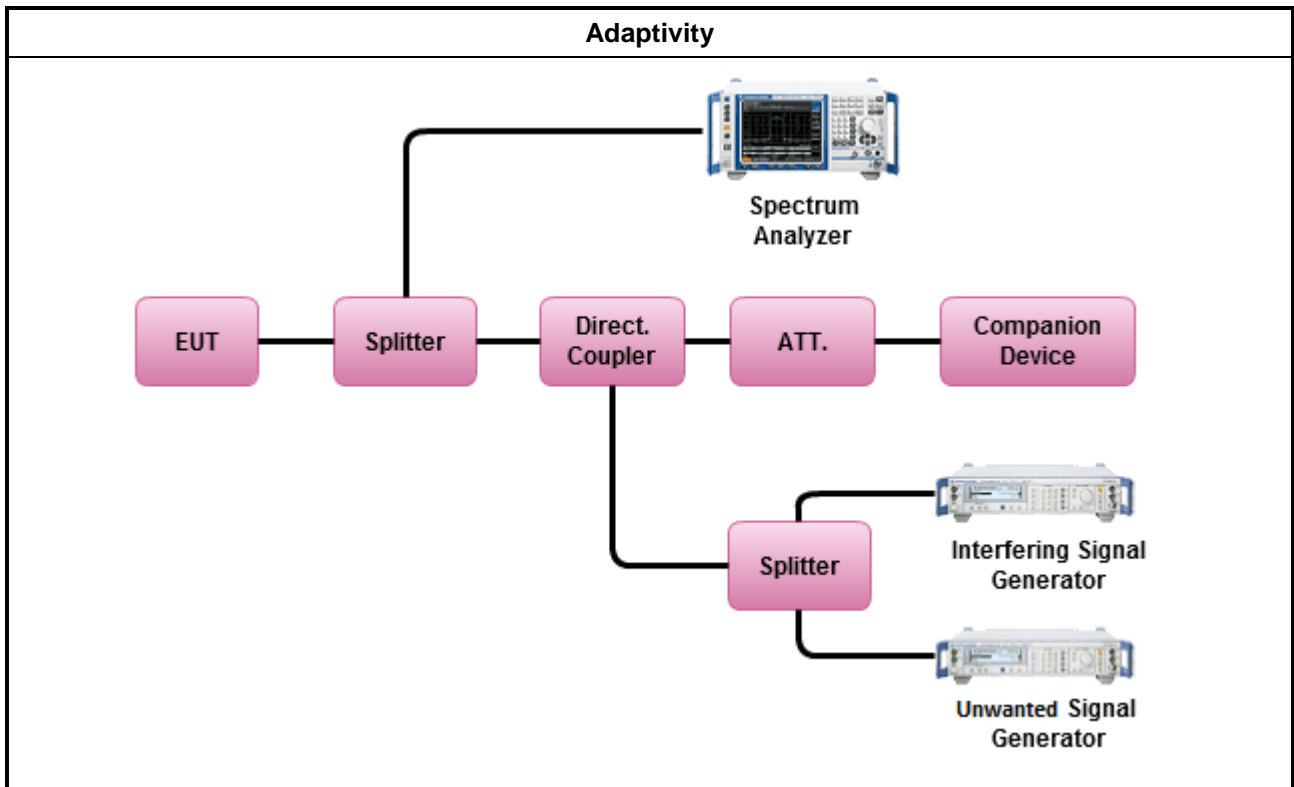

### 5.1.5 Test Result of Adaptivity

Refer as Appendix G

## 6 Receiver Blocking Test Result

### 6.1 Receiver Blocking

#### 6.1.1 Receiver Blocking Limit

Receiver Blocking Limit	
<input checked="" type="checkbox"/>	Receiver Category 1: Adaptive equipment with a maximum RF output power greater than 10 dBm e.i.r.p. shall be considered as receiver category 1 equipment.
<input type="checkbox"/>	Receiver Category 2: Non-adaptive equipment with a Medium Utilization (MU) factor greater than 1 % and less than or equal to 10 % or adaptive equipment with a maximum RF output power of 10 dBm e.i.r.p. shall be considered as receiver category 2 equipment.
<input type="checkbox"/>	Receiver Category 3: Non-adaptive equipment with a maximum Medium Utilization (MU) factor of 1 % or adaptive equipment with a maximum RF output power of 0 dBm e.i.r.p. shall be considered as receiver category 3 equipment.

Table 1: Receiver Blocking Parameters for Receiver Category 1 Equipment			
Wanted signal mean power from companion device (dBm) (see notes 1 and 4)	Blocking signal frequency (MHz)	Blocking signal power (dBm) (see note 2)	Type of blocking signal
(-133 dBm + 10 × log <sub>10</sub> (OCBW)) or -68 dBm whichever is less (see note 2)	2 380	-34	CW
	2 504		
(-139 dBm + 10 × log <sub>10</sub> (OCBW)) or -74 dBm whichever is less (see note 3)	2 300, 2 330	-34	CW
	2 360, 2 524		
	2 584, 2 674		
<p>NOTE 1: OCBW is in Hz.</p> <p>NOTE 2: In case of radiated measurements using a companion device and the level of the wanted signal from the companion device cannot be determined, a relative test may be performed using a wanted signal up to P<sub>min</sub> + 26 dB where P<sub>min</sub> is the minimum level of wanted signal required to meet the minimum performance criteria as defined in clause 4.3.1.12.3 in the absence of any blocking signal.</p> <p>NOTE 3: In case of radiated measurements using a companion device and the level of the wanted signal from the companion device cannot be determined, a relative test may be performed using a wanted signal up to P<sub>min</sub> + 20 dB where P<sub>min</sub> is the minimum level of wanted signal required to meet the minimum performance criteria as defined in clause 4.3.1.12.3 in the absence of any blocking signal.</p> <p>NOTE 4: The level specified is the level at the UUT receiver input assuming a 0 dBi antenna assembly gain. In case of conducted measurements, this level has to be corrected for the (in-band) antenna assembly gain (G). In case of radiated measurements, this level is equivalent to a power flux density (PFD) in front of the UUT antenna with the UUT being configured/positioned as recorded in clause 5.4.3.2.2.</p>			

**Table 2: Receiver Blocking Parameters for Receiver Category 2 Equipment**

Wanted signal mean power from companion device (dBm) (see notes 1 and 3)	Blocking signal frequency (MHz)	Blocking signal power (dBm) (see note 2)	Type of blocking signal
(-139 dBm + 10 × log <sub>10</sub> (OCBW) + 10 dB) or (-74 dBm + 10 dB) whichever is less (see note 2)	2 380, 2 504 2 300, 2 584	-34	CW
NOTE 1: OCBW is in Hz. NOTE 2: In case of radiated measurements using a companion device and the level of the wanted signal from the companion device cannot be determined, a relative test may be performed using a wanted signal up to P <sub>min</sub> + 26 dB where P <sub>min</sub> is the minimum level of wanted signal required to meet the minimum performance criteria as defined in clause 4.3.1.12.3 in the absence of any blocking signal. NOTE 3: The level specified is the level at the UUT receiver input assuming a 0 dBi antenna assembly gain. In case of conducted measurements, this level has to be corrected for the (in-band) antenna assembly gain (G). In case of radiated measurements, this level is equivalent to a power flux density (PFD) in front of the UUT antenna with the UUT being configured/positioned as recorded in clause 5.4.3.2.2.			

**Table 3: Receiver Blocking Parameters for Receiver Category 3 Equipment**

Wanted signal mean power from companion device (dBm) (see notes 1 and 3)	Blocking signal frequency (MHz)	Blocking signal power (dBm) (see note 2)	Type of blocking signal
(-139 dBm + 10 × log <sub>10</sub> (OCBW) + 20 dB) or (-74 dBm + 20 dB) whichever is less (see note 2)	2 380, 2 504 2 300, 2 584	-34	CW
NOTE 1: OCBW is in Hz. NOTE 2: In case of radiated measurements using a companion device and the level of the wanted signal from the companion device cannot be determined, a relative test may be performed using a wanted signal up to P <sub>min</sub> + 30 dB where P <sub>min</sub> is the minimum level of wanted signal required to meet the minimum performance criteria as defined in clause 4.3.1.12.3 in the absence of any blocking signal. NOTE 3: The level specified is the level at the UUT receiver input assuming a 0 dBi antenna assembly gain. In case of conducted measurements, this level has to be corrected for the (in-band) antenna assembly gain (G). In case of radiated measurements, this level is equivalent to a power flux density (PFD) in front of the UUT antenna with the UUT being configured/positioned as recorded in clause 5.4.3.2.2.			

## 6.1.2 Measuring Instruments

Refer a test equipment and calibration data table in this test report.

**6.1.3 Test Procedures**

<b>Test Method</b>	
<input checked="" type="checkbox"/>	Refer as EN 300 328, clause 5.4.11.2.1 for conducted measurement.
<input checked="" type="checkbox"/>	For systems using multiple receive chains only one chain (antenna port) need to be tested. All other receiver inputs shall be terminated. For non-frequency hopping equipment, the UUT shall be set to the lowest operating channel.
	Step 1 The blocking signal generator is set to the first frequency as defined in the appropriate table corresponding to the receiver category and type of equipment.
	Step 2 With the blocking signal generator switched off, a communication link is established between the UUT and the associated companion device using the test setup shown in figure 6. Unless the option provided in note 2 of the applicable table referred to in clause 5.4.11.2.1 is used, the level of the wanted signal shall be set to the value provided in the table corresponding to the receiver category and type of equipment. The test procedure defined in clause 5.4.2, and more in particular clause 5.4.2.2.1.2, can be used to measure the (conducted) level of the wanted signal however no correction shall be made for antenna gain of the companion device (step 6 in clause 5.4.2.2.1.2 shall be ignored). This level may be measured directly at the output of the companion device and a correction is made for the coupling loss into the UUT. The actual level for the wanted signal shall be recorded in the test report. When the option provided in note 2 of the applicable table referred to in clause 5.4.11.2.1 is used, the attenuation of the variable attenuator shall be increased in 1 dB steps to a value at which the minimum performance criteria as specified in clause 4.3.1.12.3 or clause 4.3.2.11.3 is still met. The resulting level for the wanted signal at the input of the UUT is Pmin. This signal level (Pmin) is increased by the value provided in note 2 of the applicable table corresponding to the receiver category and type of equipment.
	Step 3 The blocking signal at the UUT is set to the level provided in the table corresponding to the receiver category and type of equipment.
	Step 4 Repeat step 2 and step 3 for each remaining combination of frequency and level for the blocking signal as provided in the table corresponding to the receiver category and type of equipment. For non-FHSS equipment, repeat step 2 to step 4 with the UUT operating at the highest operating channel on which the blocking test has to be performed (see clause 5.4.11.1). It shall be assessed and recorded in the test report whether the UUT complies with the Receiver Blocking requirement.
<input type="checkbox"/>	Refer as EN 300 328, clause 5.4.11.2.2 for radiated measurement.

### 6.1.4 Test Setup

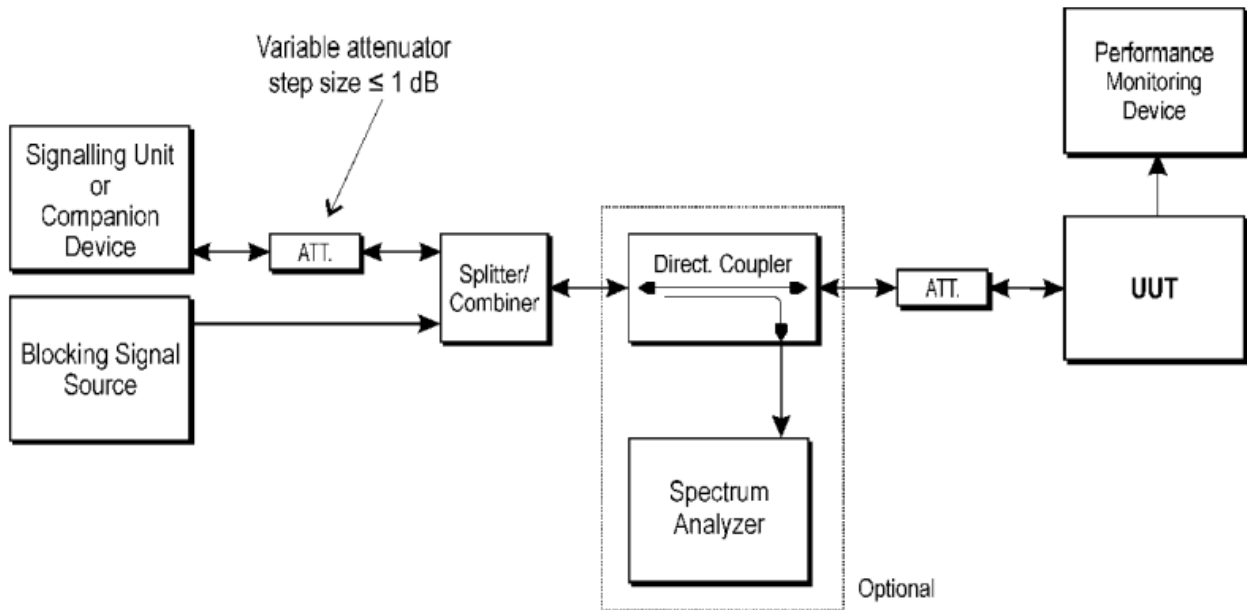

### 6.1.5 Test Result of Receiver Blocking

Refer as Appendix H

## 7 Test Equipment and Calibration Data

### Instrument for Conducted Test

Instrument	Manufacturer /Brand	Model No.	Serial No.	Spec.	Calibration Date	Calibration Due Date
Signal Analyzer	R&S	FSV 40	101013	10Hz~40GHz	01/Apr/2022	31/Mar/2023
Programmable Temp. & Humi. Chamber	Giant Force	GTH-225-40-C P-AR	MAA1611-005	-40~100°C	15/Dec/2021	14/Dec/2022
Signal Generator	Keysight	N5171B	MY53051240	9kHz~6GHz	24/Nov/2021	23/Nov/2022
USB Wideband Power Sensor	Agilent	U2021XA	MY54320011	50MHz~18GHz	17/Aug/2022	16/Aug/2023
USB Wideband Power Sensor	Agilent	U2021XA	MY54320013	50MHz~18GHz	17/Aug/2022	16/Aug/2023
SENSE-300328_DTS	Sporton	V5.10.7.15	N/A	N/A	N/A	N/A

### Instrument for Radiated Test

Instrument	Manufacturer /Brand	Model No.	Serial No.	Spec.	Calibration Date	Calibration Due Date
Signal Analyzer	R&S	FSV40	101514	10Hz~40GHz	04/May/2022	03/May/2023
Amplifier	Agilent	8447D	2944A11146	100kHz~1.3GHz	01/Sep/2022	31/Aug/2023
Microwave Preamplifier	EMC INSTRUMENT	EMC051845BE	980241	1GHz~18GHz	13/May/2022	12/May/2023
Bilog Antenna & 6dB Attenuator	SCHAFFNER	CBL6111C & N-6-06	2737 & AT-N0603	30MHz~1GHz	28/Aug/2022	27/Aug/2023
Double Ridged Guide Horn Antenna	ETS · LINDGREN	3117	00091920	1GHz~18GHz	25/Nov/2021	24/Nov/2022
RF Cable	Jye Bao	SUOFLEX 104	CB001+F1403+ SN329367/4	30MHz~1GHz	16/Mar/2022	15/Mar/2023
RF Cable	HUBER+SUHNER	SUOFLEX 104	SN345669/4+M Y34919/4	1GHz~40GHz	16/Mar/2022	15/Mar/2023
SENSE-300328_DTS	Sporton	V5.10.7.15	N/A	N/A	N/A	N/A

### Instrument for Adaptivity Test

Instrument	Manufacturer /Brand	Model No.	Serial No.	Spec.	Calibration Date	Calibration Due Date
Spectrum Analyzer	R&S	FSP7	100641	9kHz ~ 7GHz	04/Oct/2022	03/Oct/2023
Signal Generator	Keysight	N5171B	MY53051240	9kHz~6GHz	24/Nov/2021	23/Nov/2022
Vector Signal Generator	Keysight	N5182B	MY53051912	9kHz~6GHz	21/Mar/2022	20/Mar/2023
DFS-Adaptivity	Sporton	Ver 2.7	N/A	N/A	N/A	N/A
Adaptivity Analysis-5G	Sporton	Ver 2.8	N/A	N/A	N/A	N/A

### Instrument for Receiver Blocking Test

Instrument	Manufacturer /Brand	Model No.	Serial No.	Spec.	Calibration Date	Calibration Due Date
Wireless connectivity tester	R&S	CMW270	100855	70MHz ~6GHz	24/Nov/2021	23/Nov/2022
Signal Generator	Keysight	N5171B	MY53051240	9kHz~6GHz	24/Nov/2021	23/Nov/2022



Summary

Mode	EIRP (dBm)	EIRP (W)
2.4-2.4835GHz	-	-
802.11b_Nss1,(1Mbps)_1TX	19.94	0.09863
802.11g_Nss1,(6Mbps)_1TX	19.92	0.09817
802.11n HT20_Nss1,(MCS0)_1TX	19.95	0.09886
802.11n HT40_Nss1,(MCS0)_1TX	19.91	0.09795

Result

Mode	Result	Gain (dBi)	Port 1 (dBm)	Total Power (dBm)	EIRP (dBm)	EIRP Limit (dBm)
802.11b_Nss1,(1Mbps)_1TX	-	-	-	-	-	-
2412MHz_Tnom	Pass	2.40	16.93	16.93	19.33	20.00
2412MHz_Tmin	Pass	2.40	17.44	17.44	19.84	20.00
2412MHz_Tmax	Pass	2.40	16.81	16.81	19.21	20.00
2442MHz_Tnom	Pass	2.40	17.04	17.04	19.44	20.00
2442MHz_Tmin	Pass	2.40	17.47	17.47	19.87	20.00
2442MHz_Tmax	Pass	2.40	16.76	16.76	19.16	20.00
2472MHz_Tnom	Pass	2.40	17.03	17.03	19.43	20.00
2472MHz_Tmin	Pass	2.40	17.54	17.54	19.94	20.00
2472MHz_Tmax	Pass	2.40	17.05	17.05	19.45	20.00
802.11g_Nss1,(6Mbps)_1TX	-	-	-	-	-	-
2412MHz_Tnom	Pass	2.40	16.94	16.94	19.34	20.00
2412MHz_Tmin	Pass	2.40	17.44	17.44	19.84	20.00
2412MHz_Tmax	Pass	2.40	16.81	16.81	19.21	20.00
2442MHz_Tnom	Pass	2.40	17.25	17.25	19.65	20.00
2442MHz_Tmin	Pass	2.40	17.52	17.52	19.92	20.00
2442MHz_Tmax	Pass	2.40	17.03	17.03	19.43	20.00
2472MHz_Tnom	Pass	2.40	17.16	17.16	19.56	20.00
2472MHz_Tmin	Pass	2.40	17.52	17.52	19.92	20.00
2472MHz_Tmax	Pass	2.40	17.07	17.07	19.47	20.00
802.11n HT20_Nss1,(MCS0)_1TX	-	-	-	-	-	-
2412MHz_Tnom	Pass	2.40	17.00	17.00	19.40	20.00
2412MHz_Tmin	Pass	2.40	17.55	17.55	19.95	20.00
2412MHz_Tmax	Pass	2.40	17.07	17.07	19.47	20.00
2442MHz_Tnom	Pass	2.40	17.06	17.06	19.46	20.00
2442MHz_Tmin	Pass	2.40	17.52	17.52	19.92	20.00
2442MHz_Tmax	Pass	2.40	16.90	16.90	19.30	20.00
2472MHz_Tnom	Pass	2.40	17.19	17.19	19.59	20.00
2472MHz_Tmin	Pass	2.40	17.55	17.55	19.95	20.00
2472MHz_Tmax	Pass	2.40	16.97	16.97	19.37	20.00
802.11n HT40_Nss1,(MCS0)_1TX	-	-	-	-	-	-
2422MHz_Tnom	Pass	2.40	16.59	16.59	18.99	20.00
2422MHz_Tmin	Pass	2.40	17.41	17.41	19.81	20.00
2422MHz_Tmax	Pass	2.40	16.65	16.65	19.05	20.00
2442MHz_Tnom	Pass	2.40	16.93	16.93	19.33	20.00
2442MHz_Tmin	Pass	2.40	17.46	17.46	19.86	20.00
2442MHz_Tmax	Pass	2.40	16.80	16.80	19.20	20.00
2462MHz_Tnom	Pass	2.40	16.90	16.90	19.30	20.00
2462MHz_Tmin	Pass	2.40	17.51	17.51	19.91	20.00
2462MHz_Tmax	Pass	2.40	16.84	16.84	19.24	20.00

Port X = Port X output power; Total Power = Total power measure all transmit ports simultaneously.

**Summary**

Mode	EIRP PD (dBm/MHz)
2.4-2.4835GHz	-
802.11b_Nss1,(1Mbps)_1TX	9.90
802.11g_Nss1,(6Mbps)_1TX	6.81
802.11n HT20_Nss1,(MCS0)_1TX	6.72
802.11n HT40_Nss1,(MCS0)_1TX	3.86

RBW=1MHz

**Result**

Mode	Result	Gain (dBi)	PD (dBm/MHz)	EIRP PD (dBm/MHz)	EIRP PD Limit (dBm/MHz)
802.11b_Nss1,(1Mbps)_1TX	-	-	-	-	-
2412MHz_Tnom	Pass	2.40	7.32	9.72	10.00
2442MHz_Tnom	Pass	2.40	7.36	9.76	10.00
2472MHz_Tnom	Pass	2.40	7.50	9.90	10.00
802.11g_Nss1,(6Mbps)_1TX	-	-	-	-	-
2412MHz_Tnom	Pass	2.40	3.97	6.37	10.00
2442MHz_Tnom	Pass	2.40	4.22	6.62	10.00
2472MHz_Tnom	Pass	2.40	4.41	6.81	10.00
802.11n HT20_Nss1,(MCS0)_1TX	-	-	-	-	-
2412MHz_Tnom	Pass	2.40	4.20	6.60	10.00
2442MHz_Tnom	Pass	2.40	4.32	6.72	10.00
2472MHz_Tnom	Pass	2.40	4.30	6.70	10.00
802.11n HT40_Nss1,(MCS0)_1TX	-	-	-	-	-
2422MHz_Tnom	Pass	2.40	0.96	3.36	10.00
2442MHz_Tnom	Pass	2.40	1.44	3.84	10.00
2462MHz_Tnom	Pass	2.40	1.46	3.86	10.00

RBW=1MHz;  
Port X = Port X power density;

**Summary**

Mode	OBW (Hz)	ITU-Code
2.4-2.4835GHz	-	-
802.11b_Nss1,(1Mbps)_1TX	13.113M	13M1G1D
802.11g_Nss1,(6Mbps)_1TX	16.652M	16M7D1D
802.11n HT20_Nss1,(MCS0)_1TX	17.831M	17M8D1D
802.11n HT40_Nss1,(MCS0)_1TX	36.302M	36M3D1D

OBW = 99% occupied bandwidth

**Result**

Mode	Result	Limit (Hz)	fl-OBW (Hz)	fh-OBW (Hz)	OBW (Hz)
802.11b_Nss1,(1Mbps)_1TX	-	-	-	-	-
2412MHz_Tnom	Pass	2.4-2.4835G	2.405443G	2.418557G	13.113M
2442MHz_Tnom	Pass	2.4-2.4835G	2.435483G	2.448537G	13.053M
2472MHz_Tnom	Pass	2.4-2.4835G	2.465423G	2.478517G	13.093M
802.11g_Nss1,(6Mbps)_1TX	-	-	-	-	-
2412MHz_Tnom	Pass	2.4-2.4835G	2.403664G	2.420316G	16.652M
2442MHz_Tnom	Pass	2.4-2.4835G	2.433684G	2.450316G	16.632M
2472MHz_Tnom	Pass	2.4-2.4835G	2.463664G	2.480316G	16.652M
802.11n HT20_Nss1,(MCS0)_1TX	-	-	-	-	-
2412MHz_Tnom	Pass	2.4-2.4835G	2.403084G	2.420916G	17.831M
2442MHz_Tnom	Pass	2.4-2.4835G	2.433084G	2.450916G	17.831M
2472MHz_Tnom	Pass	2.4-2.4835G	2.463064G	2.480896G	17.831M
802.11n HT40_Nss1,(MCS0)_1TX	-	-	-	-	-
2422MHz_Tnom	Pass	2.4-2.4835G	2.403849G	2.440151G	36.302M
2442MHz_Tnom	Pass	2.4-2.4835G	2.423889G	2.460151G	36.262M
2462MHz_Tnom	Pass	2.4-2.4835G	2.443849G	2.480111G	36.262M

fl-OBW = fl lower edge 99% occupied bandwidth; fh-OBW = fh higher edge 99% occupied bandwidth; OBW = 99% occupied bandwidth; N dB = 6dB down bandwidth

### 802.11b\_Nss1,(1Mbps)\_1TX

EBW

2412MHz

07/11/2022

CF  
2.412GHz

Span  
40MHz

RBW  
500kHz

VBW  
2MHz

Sweep Time  
1s

Detector Type  
RMS

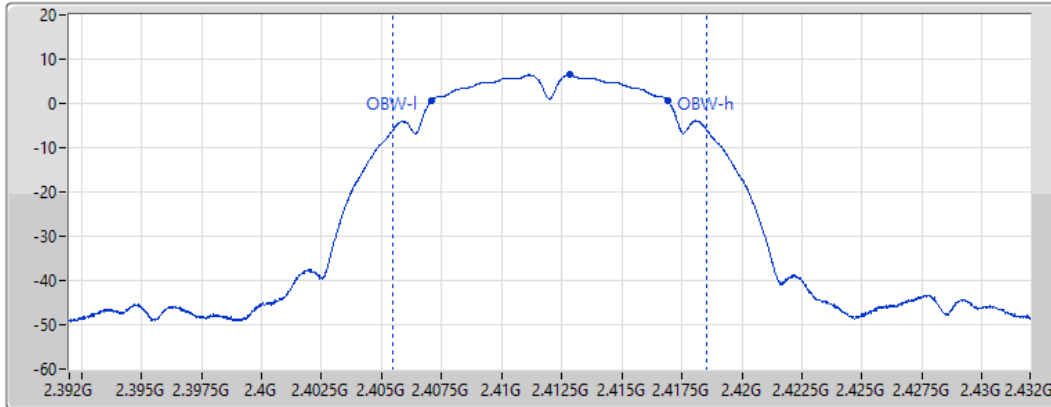

Port 1 

6dB(Hz)	Fl-6dB(Hz)	Fh-6dB(Hz)	OBW(Hz)	Fl-OBW(Hz)	Fh-OBW(Hz)	Limit(Hz)	Port
9.88M	2.40706G	2.41694G	13.113M	2.405443G	2.418557G	2.4-2.4835G	1

### 802.11b\_Nss1,(1Mbps)\_1TX

EBW

2442MHz

07/11/2022

CF  
2.442GHz

Span  
40MHz

RBW  
500kHz

VBW  
2MHz

Sweep Time  
1s

Detector Type  
RMS

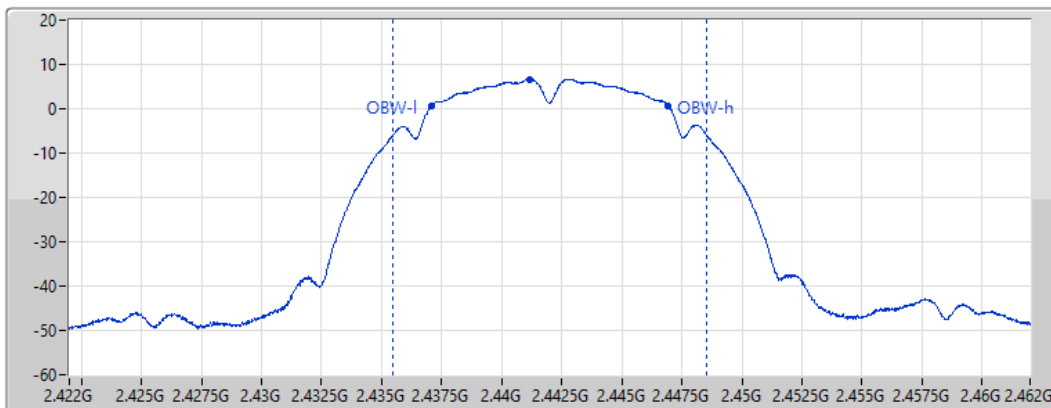

Port 1 

6dB(Hz)	Fl-6dB(Hz)	Fh-6dB(Hz)	OBW(Hz)	Fl-OBW(Hz)	Fh-OBW(Hz)	Limit(Hz)	Port
9.88M	2.43706G	2.44694G	13.053M	2.435483G	2.448537G	2.4-2.4835G	1

### 802.11b\_Nss1,(1Mbps)\_1TX

EBW

2472MHz

07/11/2022

CF  
2.472GHz

Span  
40MHz

RBW  
500kHz

VBW  
2MHz

Sweep Time  
1s

Detector Type  
RMS

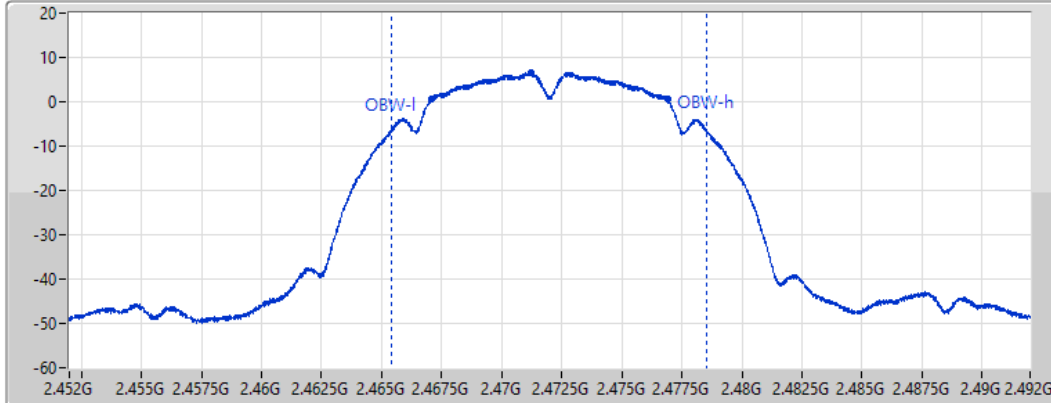

Port 1

6dB(Hz)	F1-6dB(Hz)	Fh-6dB(Hz)	OBW(Hz)	F1-OBW(Hz)	Fh-OBW(Hz)	Limit(Hz)	Port
9.84M	2.46706G	2.4769G	13.093M	2.465423G	2.478517G	2.4-2.4835G	1

### 802.11g\_Nss1,(6Mbps)\_1TX

EBW

2412MHz

07/11/2022

CF  
2.412GHz

Span  
40MHz

RBW  
500kHz

VBW  
2MHz

Sweep Time  
1s

Detector Type  
RMS

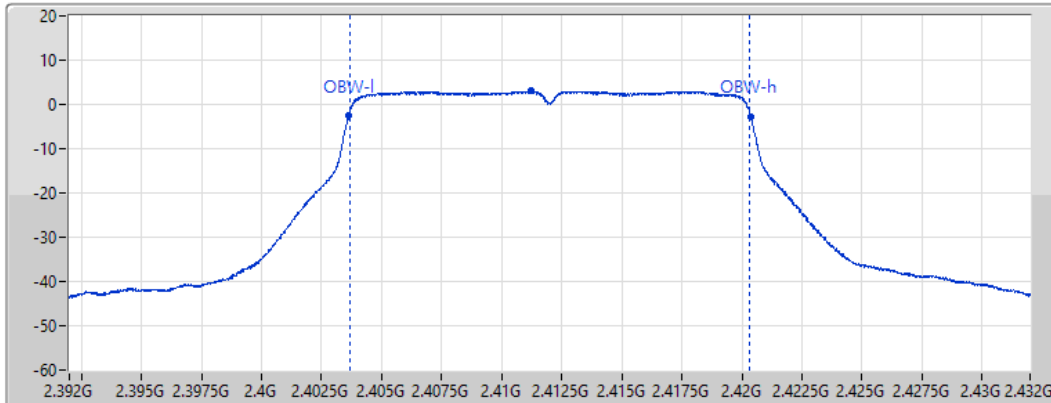

Port 1

6dB(Hz)	F1-6dB(Hz)	Fh-6dB(Hz)	OBW(Hz)	F1-OBW(Hz)	Fh-OBW(Hz)	Limit(Hz)	Port
16.76M	2.40362G	2.42038G	16.652M	2.403664G	2.420316G	2.4-2.4835G	1

802.11g\_Nss1,(6Mbps)\_1TX

EBW

2442MHz

07/11/2022

CF  
2.442GHz

Span  
40MHz

RBW  
500kHz

VBW  
2MHz

Sweep Time  
1s

Detector Type  
RMS

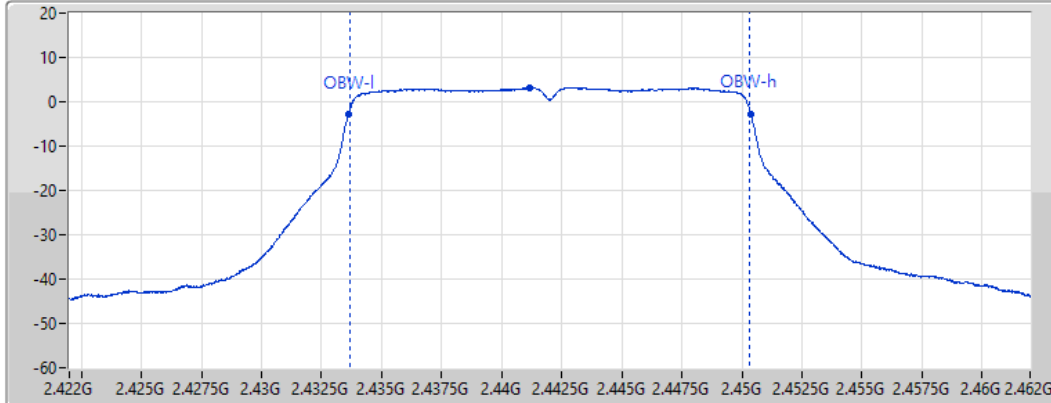

Port 1

6dB(Hz)	Fl-6dB(Hz)	Fh-6dB(Hz)	OBW(Hz)	Fl-OBW(Hz)	Fh-OBW(Hz)	Limit(Hz)	Port
16.76M	2.43362G	2.45038G	16.632M	2.433684G	2.450316G	2.4-2.4835G	1

802.11g\_Nss1,(6Mbps)\_1TX

EBW

2472MHz

07/11/2022

CF  
2.472GHz

Span  
40MHz

RBW  
500kHz

VBW  
2MHz

Sweep Time  
1s

Detector Type  
RMS

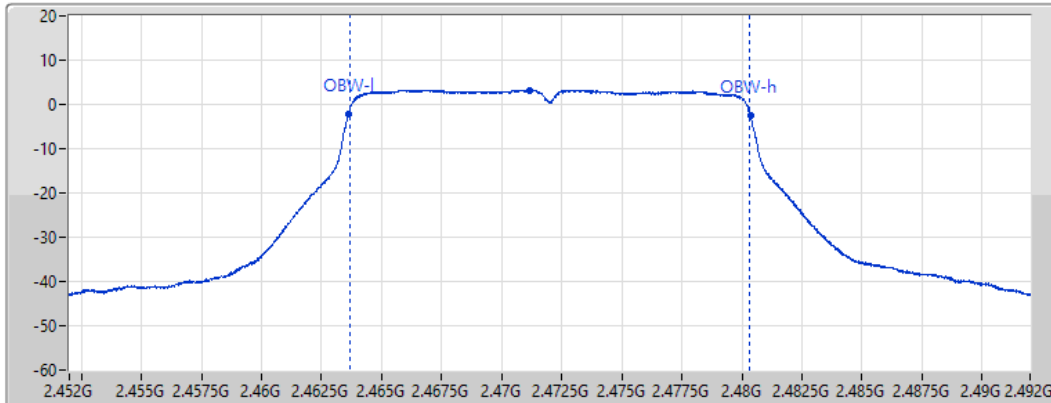

Port 1

6dB(Hz)	Fl-6dB(Hz)	Fh-6dB(Hz)	OBW(Hz)	Fl-OBW(Hz)	Fh-OBW(Hz)	Limit(Hz)	Port
16.74M	2.46362G	2.48036G	16.652M	2.463664G	2.480316G	2.4-2.4835G	1

802.11n HT20\_Nss1,(MCS0)\_1TX

EBW

2412MHz

07/11/2022

CF  
2.412GHz

Span  
40MHz

RBW  
500kHz

VBW  
2MHz

Sweep Time  
1s

Detector Type  
RMS

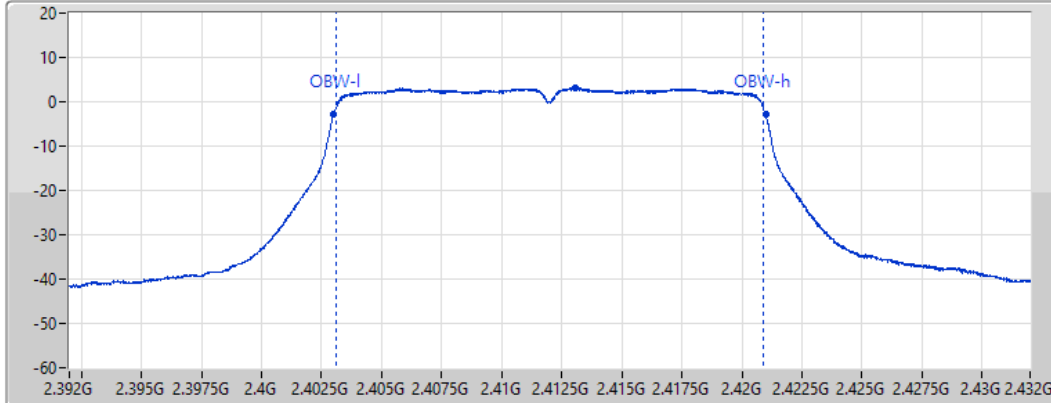

Port 1 

6dB(Hz)	Fl-6dB(Hz)	Fh-6dB(Hz)	OBW(Hz)	Fl-OBW(Hz)	Fh-OBW(Hz)	Limit(Hz)	Port
17.98M	2.403G	2.42098G	17.831M	2.403084G	2.420916G	2.4-2.4835G	1

802.11n HT20\_Nss1,(MCS0)\_1TX

EBW

2442MHz

07/11/2022

CF  
2.442GHz

Span  
40MHz

RBW  
500kHz

VBW  
2MHz

Sweep Time  
1s

Detector Type  
RMS

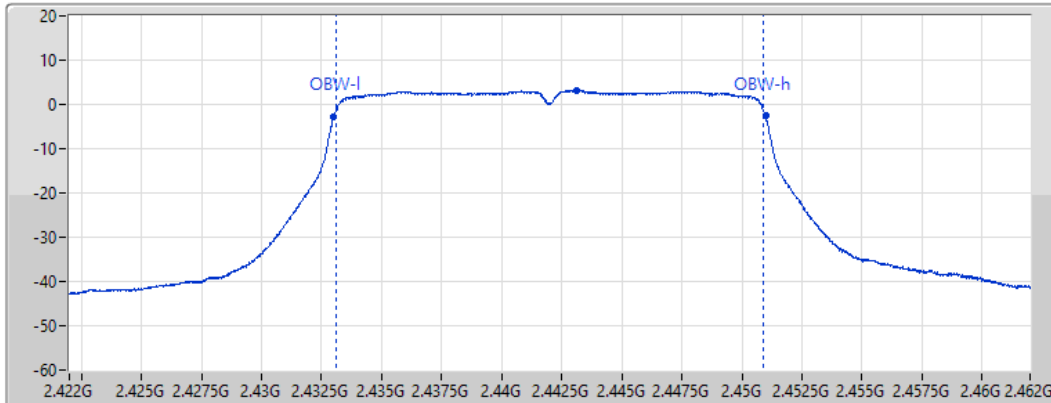

Port 1 

6dB(Hz)	Fl-6dB(Hz)	Fh-6dB(Hz)	OBW(Hz)	Fl-OBW(Hz)	Fh-OBW(Hz)	Limit(Hz)	Port
17.96M	2.43302G	2.45098G	17.831M	2.433084G	2.450916G	2.4-2.4835G	1

802.11n HT20\_Nss1,(MCS0)\_1TX

EBW

2472MHz

07/11/2022

CF  
2.472GHz

Span  
40MHz

RBW  
500kHz

VBW  
2MHz

Sweep Time  
1s

Detector Type  
RMS

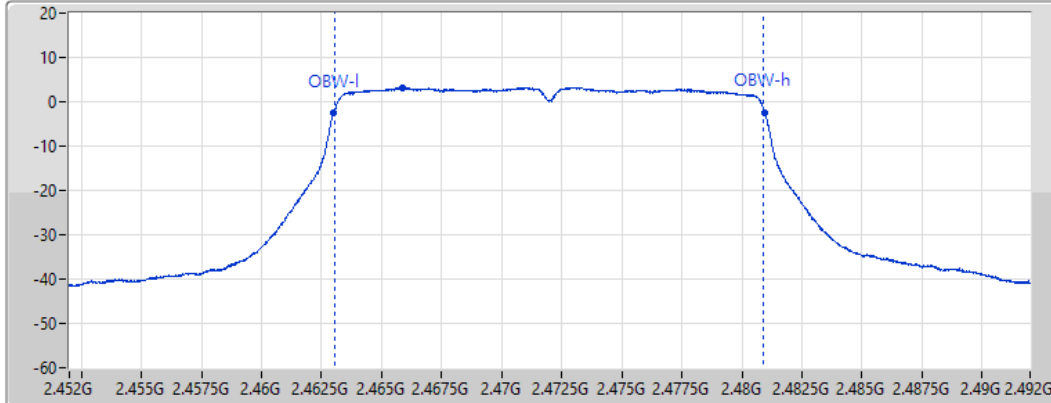

Port 1

6dB(Hz)	Fl-6dB(Hz)	Fh-6dB(Hz)	OBW(Hz)	Fl-OBW(Hz)	Fh-OBW(Hz)	Limit(Hz)	Port
17.96M	2.463G	2.48096G	17.831M	2.463064G	2.480896G	2.4-2.4835G	1

802.11n HT40\_Nss1,(MCS0)\_1TX

EBW

2422MHz

07/11/2022

CF  
2.422GHz

Span  
80MHz

RBW  
1MHz

VBW  
3MHz

Sweep Time  
1s

Detector Type  
RMS

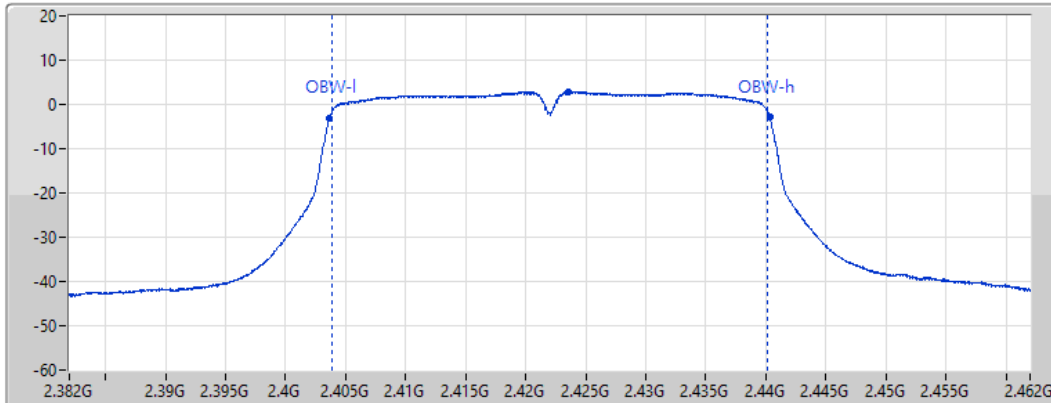

Port 1

6dB(Hz)	Fl-6dB(Hz)	Fh-6dB(Hz)	OBW(Hz)	Fl-OBW(Hz)	Fh-OBW(Hz)	Limit(Hz)	Port
36.64M	2.40368G	2.44032G	36.302M	2.403849G	2.440151G	2.4-2.4835G	1

802.11n HT40\_Nss1,(MCS0)\_1TX

EBW

2442MHz

07/11/2022

CF  
2.442GHz

Span  
80MHz

RBW  
1MHz

VBW  
3MHz

Sweep Time  
1s

Detector Type  
RMS

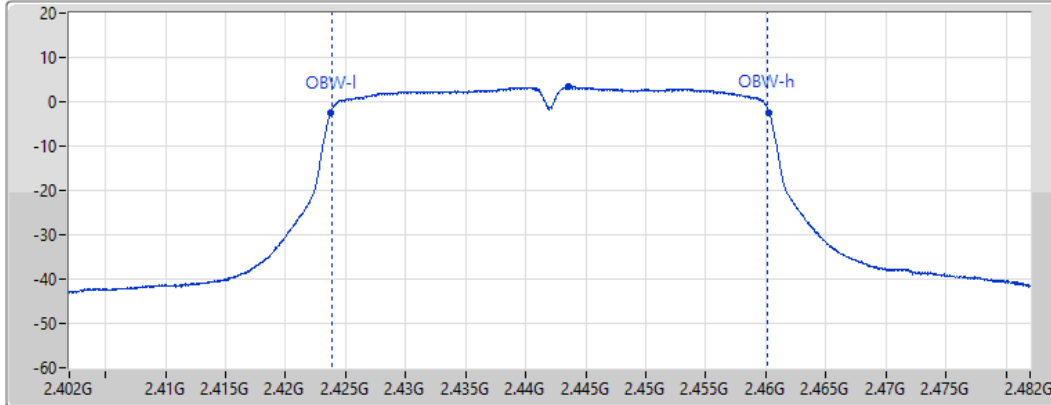

Port 1

6dB(Hz)	Fl-6dB(Hz)	Fh-6dB(Hz)	OBW(Hz)	Fl-OBW(Hz)	Fh-OBW(Hz)	Limit(Hz)	Port
36.52M	2.42376G	2.46028G	36.262M	2.423889G	2.460151G	2.4-2.4835G	1

802.11n HT40\_Nss1,(MCS0)\_1TX

EBW

2462MHz

07/11/2022

CF  
2.462GHz

Span  
80MHz

RBW  
1MHz

VBW  
3MHz

Sweep Time  
1s

Detector Type  
RMS

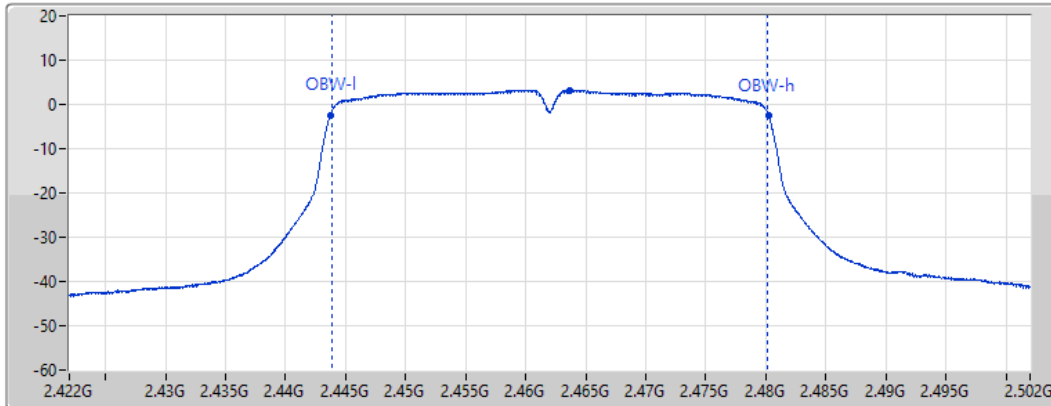

Port 1

6dB(Hz)	Fl-6dB(Hz)	Fh-6dB(Hz)	OBW(Hz)	Fl-OBW(Hz)	Fh-OBW(Hz)	Limit(Hz)	Port
36.52M	2.44372G	2.48024G	36.262M	2.443849G	2.480111G	2.4-2.4835G	1

**Summary**

Mode	EIRP-A (dBm)	Limit-A (dBm)	EIRP-B (dBm)	Limit-B (dBm)
2.4-2.4835GHz	-	-	-	-
802.11b_Nss1,(1Mbps)_1TX	-38.68	-10	-41.69	-20
802.11g_Nss1,(6Mbps)_1TX	-27.19	-10	-42.95	-20
802.11n HT20_Nss1,(MCS0)_1TX	-26.69	-10	-42.69	-20
802.11n HT40_Nss1,(MCS0)_1TX	-27.36	-10	-44.18	-20

**Result**

Mode	Result	Freq (Hz)	EIRP (dBm)	Limit (dBm)	Freq (Hz)	EIRP (dBm)	Limit (dBm)
802.11b_Nss1,(1Mbps)_1TX	-	-	-	-	-	-	-
2412MHz_Tnom	Pass	2.386387G	-42.20	-20	2.3965G	-41.18	-10
2412MHz_Tnom	Pass	2.509226G	-47.43	-20	2.485G	-47.74	-10
2472MHz_Tnom	Pass	2.383407G	-48.82	-20	2.3995G	-47.28	-10
2472MHz_Tnom	Pass	2.498093G	-41.69	-20	2.487G	-38.68	-10
802.11g_Nss1,(6Mbps)_1TX	-	-	-	-	-	-	-
2412MHz_Tnom	Pass	2.382848G	-43.44	-20	2.3995G	-31.42	-10
2412MHz_Tnom	Pass	2.504652G	-47.54	-20	2.489G	-47.49	-10
2472MHz_Tnom	Pass	2.381848G	-49.00	-20	2.3995G	-47.38	-10
2472MHz_Tnom	Pass	2.500652G	-42.95	-20	2.484G	-27.19	-10
802.11n HT20_Nss1,(MCS0)_1TX	-	-	-	-	-	-	-
2412MHz_Tnom	Pass	2.381669G	-42.98	-20	2.3995G	-29.93	-10
2412MHz_Tnom	Pass	2.504831G	-47.66	-20	2.495G	-47.69	-10
2472MHz_Tnom	Pass	2.379669G	-48.75	-20	2.3995G	-47.57	-10
2472MHz_Tnom	Pass	2.502831G	-42.69	-20	2.484G	-26.69	-10
802.11n HT40_Nss1,(MCS0)_1TX	-	-	-	-	-	-	-
2422MHz_Tnom	Pass	2.363198G	-45.62	-20	2.3995G	-29.84	-10
2422MHz_Tnom	Pass	2.525302G	-47.51	-20	2.487G	-46.02	-10
2462MHz_Tnom	Pass	2.341238G	-49.51	-20	2.3995G	-45.12	-10
2462MHz_Tnom	Pass	2.521262G	-44.18	-20	2.484G	-27.36	-10

802.11b\_Nss1,(1Mbps)\_1TX

MASK-DTS

2412MHz\_Tnom

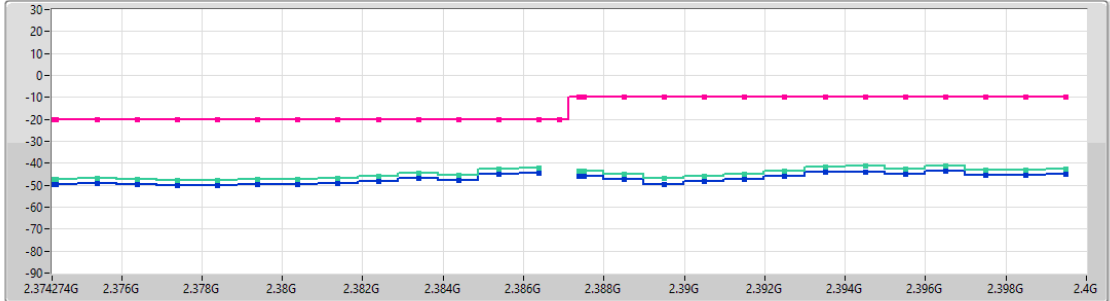

07/11/2022

Limit

EIRP

Port 1

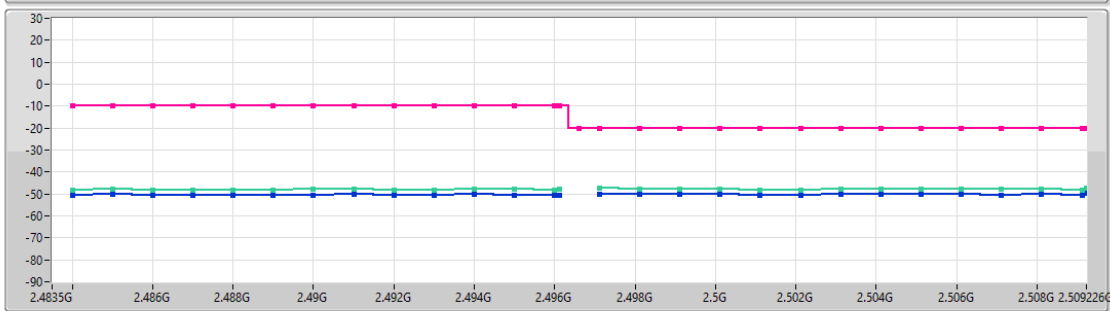

Limit

EIRP

Port 1

Freq(Hz)	EIRP(dBm)	Limit(dBm)	Freq(Hz)	EIRP(dBm)	Limit(dBm)	Freq(Hz)	EIRP(dBm)	Limit(dBm)	Freq(Hz)	EIRP(dBm)	Limit(dBm)
2.386387G	-42.20	-20	2.3965G	-41.18	-10	2.485G	-47.74	-10	2.509226G	-47.43	-20

802.11b\_Nss1,(1Mbps)\_1TX

MASK-DTS

2472MHz\_Tnom

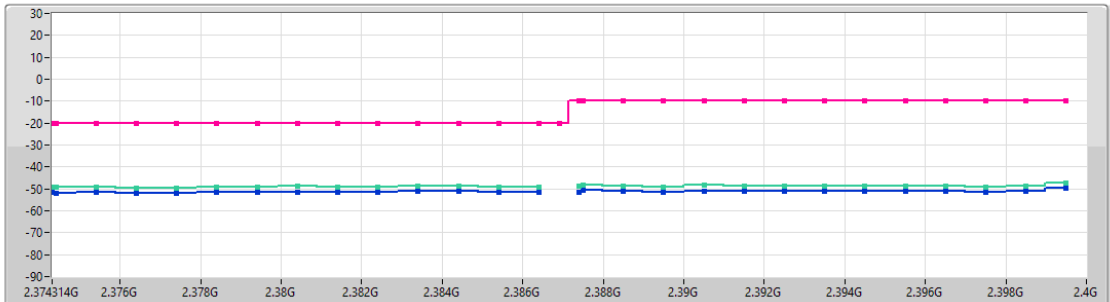

07/11/2022

Limit

EIRP

Port 1

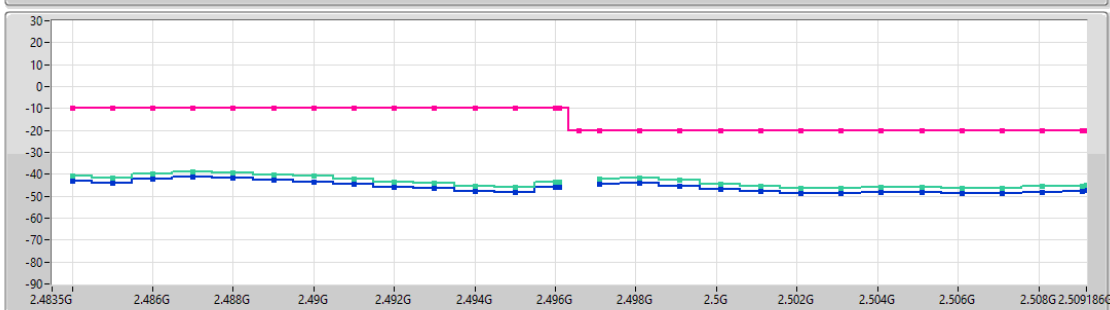

Limit

EIRP

Port 1

Freq(Hz)	EIRP(dBm)	Limit(dBm)	Freq(Hz)	EIRP(dBm)	Limit(dBm)	Freq(Hz)	EIRP(dBm)	Limit(dBm)	Freq(Hz)	EIRP(dBm)	Limit(dBm)
2.383407G	-48.82	-20	2.3995G	-47.28	-10	2.487G	-38.68	-10	2.498093G	-41.69	-20

802.11g\_Nss1,(6Mbps)\_1TX  
2412MHz\_Tnom

MASK-DTS

07/11/2022

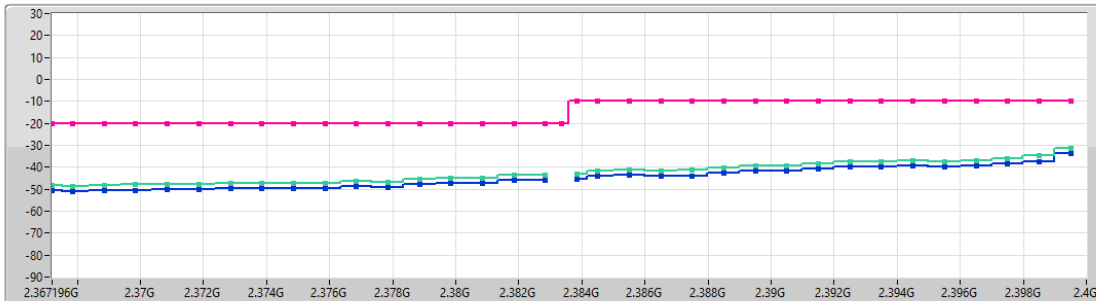

Limit

EIRP

Port 1

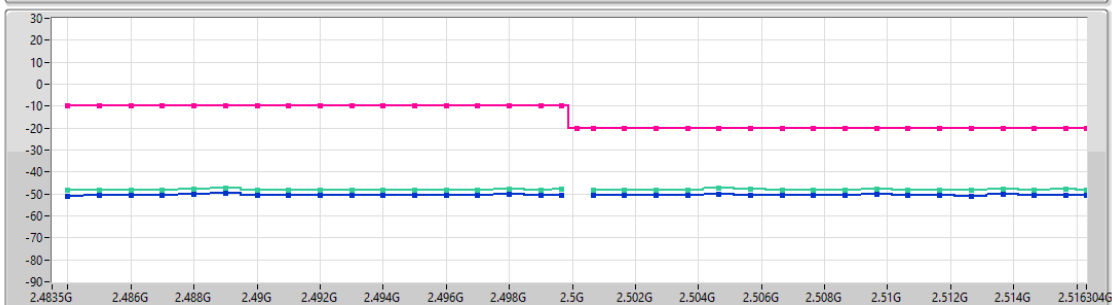

Limit

EIRP

Port 1

Freq(Hz)	EIRP(dBm)	Limit(dBm)	Freq(Hz)	EIRP(dBm)	Limit(dBm)	Freq(Hz)	EIRP(dBm)	Limit(dBm)	Freq(Hz)	EIRP(dBm)	Limit(dBm)
2.382848G	-43.44	-20	2.3995G	-31.42	-10	2.489G	-47.49	-10	2.504652G	-47.54	-20

802.11g\_Nss1,(6Mbps)\_1TX  
2472MHz\_Tnom

MASK-DTS

07/11/2022

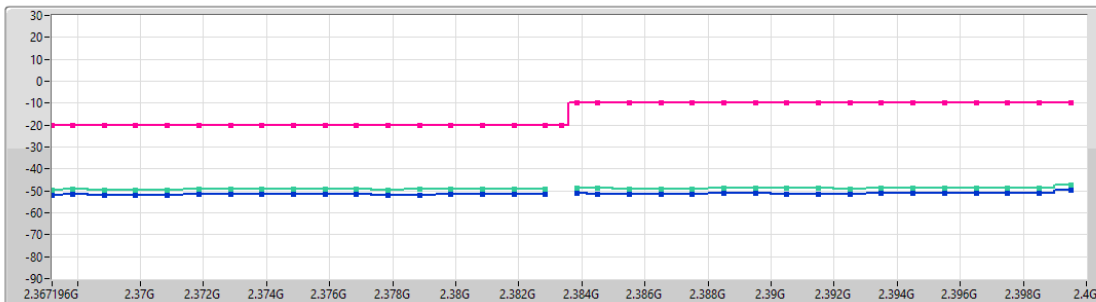

Limit

EIRP

Port 1

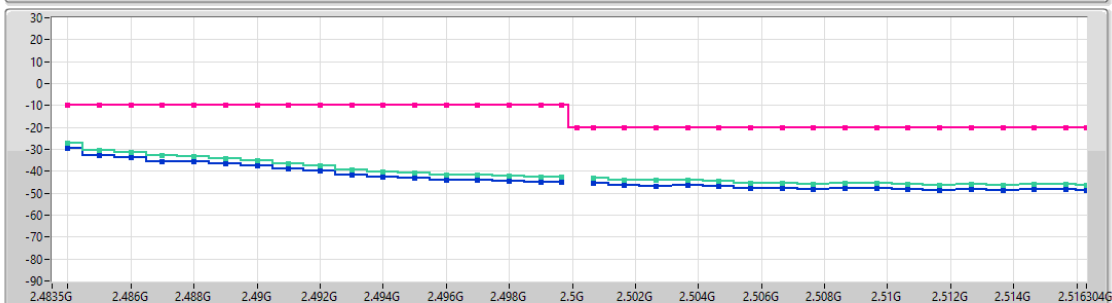

Limit

EIRP

Port 1

Freq(Hz)	EIRP(dBm)	Limit(dBm)	Freq(Hz)	EIRP(dBm)	Limit(dBm)	Freq(Hz)	EIRP(dBm)	Limit(dBm)	Freq(Hz)	EIRP(dBm)	Limit(dBm)
2.381848G	-49.00	-20	2.3995G	-47.38	-10	2.484G	-27.19	-10	2.500652G	-42.95	-20

802.11n HT20\_Nss1,(MCS0)\_1TX  
2412MHz\_Tnom

MASK-DTS

07/11/2022

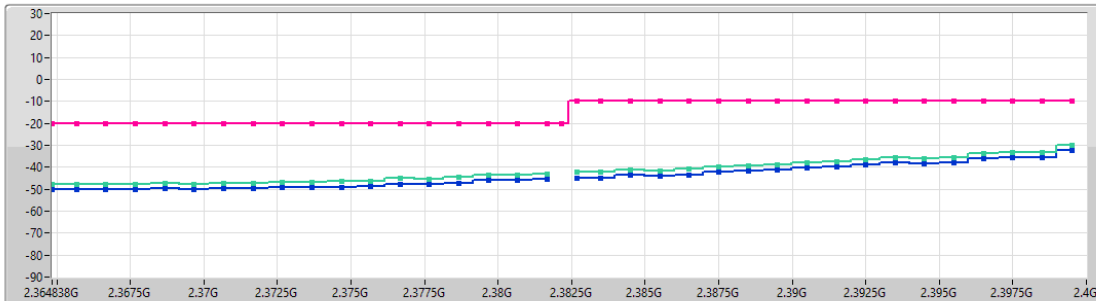

Limit

EIRP

Port 1

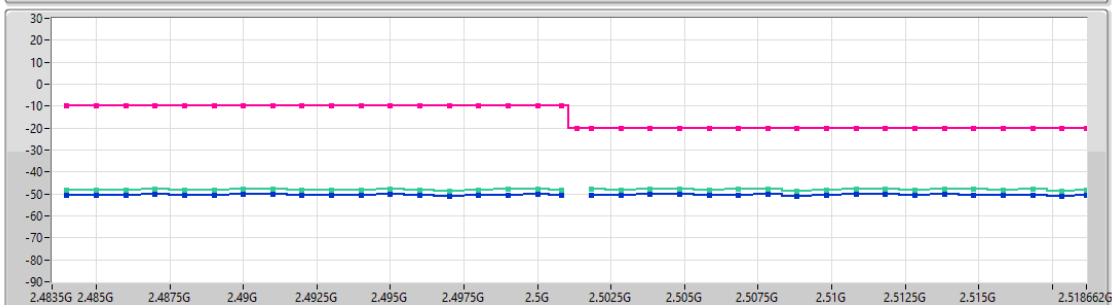

Limit

EIRP

Port 1

Freq(Hz)	EIRP(dBm)	Limit(dBm)	Freq(Hz)	EIRP(dBm)	Limit(dBm)	Freq(Hz)	EIRP(dBm)	Limit(dBm)	Freq(Hz)	EIRP(dBm)	Limit(dBm)
2.381669G	-42.98	-20	2.3995G	-29.93	-10	2.495G	-47.69	-10	2.504831G	-47.66	-20

802.11n HT20\_Nss1,(MCS0)\_1TX  
2472MHz\_Tnom

MASK-DTS

07/11/2022

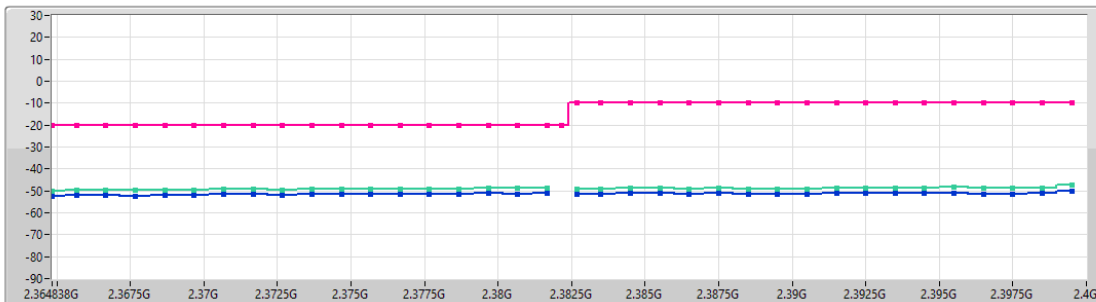

Limit

EIRP

Port 1

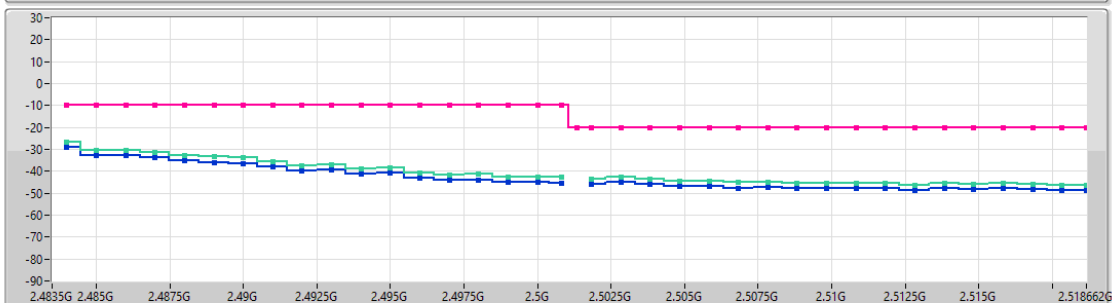

Limit

EIRP

Port 1

Freq(Hz)	EIRP(dBm)	Limit(dBm)	Freq(Hz)	EIRP(dBm)	Limit(dBm)	Freq(Hz)	EIRP(dBm)	Limit(dBm)	Freq(Hz)	EIRP(dBm)	Limit(dBm)
2.379669G	-48.75	-20	2.3995G	-47.57	-10	2.484G	-26.69	-10	2.502831G	-42.69	-20

802.11n HT40\_Nss1,(MCS0)\_1TX  
2422MHz\_Tnom

MASK-DTS

07/11/2022

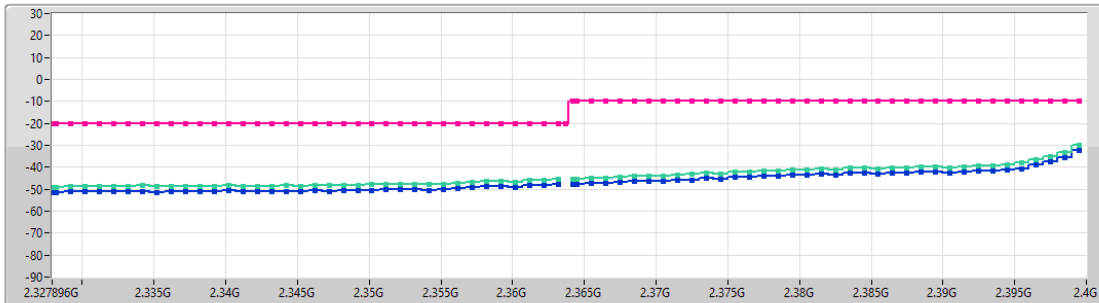

Limit

EIRP

Port 1

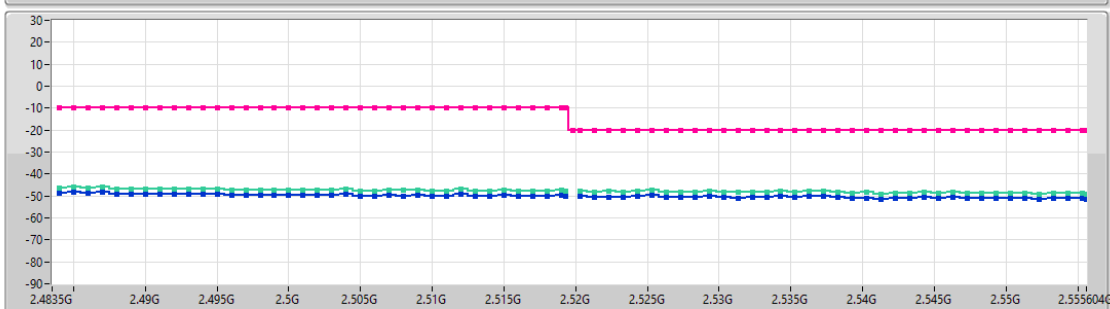

Limit

EIRP

Port 1

Freq(Hz)	EIRP(dBm)	Limit(dBm)	Freq(Hz)	EIRP(dBm)	Limit(dBm)	Freq(Hz)	EIRP(dBm)	Limit(dBm)	Freq(Hz)	EIRP(dBm)	Limit(dBm)
2.363198G	-45.62	-20	2.3995G	-29.84	-10	2.487G	-46.02	-10	2.525302G	-47.51	-20

802.11n HT40\_Nss1,(MCS0)\_1TX  
2462MHz\_Tnom

MASK-DTS

07/11/2022

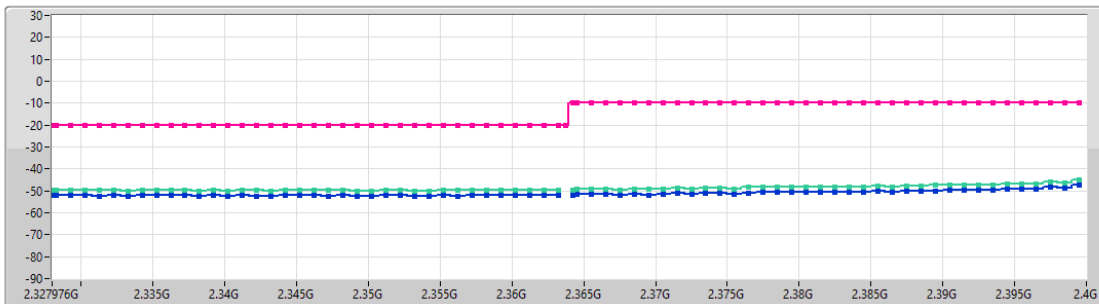

Limit

EIRP

Port 1

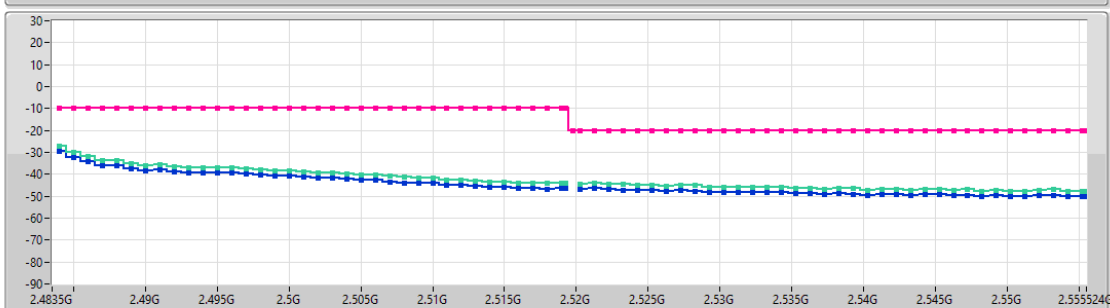

Limit

EIRP

Port 1

Freq(Hz)	EIRP(dBm)	Limit(dBm)	Freq(Hz)	EIRP(dBm)	Limit(dBm)	Freq(Hz)	EIRP(dBm)	Limit(dBm)	Freq(Hz)	EIRP(dBm)	Limit(dBm)
2.341238G	-49.51	-20	2.3995G	-45.12	-10	2.484G	-27.36	-10	2.521262G	-44.18	-20



Summary

Mode	Result	Type	Freq (Hz)	Level (dBm)	Limit (dBm)	Margin (dB)	Factor (dB)	Dist (m)	Condition	Azimuth (°)	Height (m)	Comments
2.4-2.4835GHz	-	-	-	-	-	-	-	-	-	-	-	-
802.11n HT40_Nss1,(MCS0)_1TX	Pass	AV	528.03M	-60.62	-54.00	-6.62	7.75	3	Horizontal	0	1.5	-

Result

Mode	Result	Type	Freq (Hz)	Level (dBm)	Limit (dBm)	Margin (dB)	Factor (dB)	Dist (m)	Condition	Azimuth (°)	Height (m)	Comments
802.11n HT40_Nss1,(MCS0)_1TX	-	-	-	-	-	-	-	-	-	-	-	-
2462MHz_TX	Pass	AV	240.01M	-72.06	-36.00	-36.06	0.32	3	Vertical	360	1.5	-
2462MHz_TX	Pass	AV	432.02M	-65.21	-36.00	-29.21	5.09	3	Vertical	360	1.5	-
2462MHz_TX	Pass	AV	528.03M	-67.21	-54.00	-13.21	6.73	3	Vertical	360	1.5	-
2462MHz_TX	Pass	AV	240.01M	-66.86	-36.00	-30.86	1.16	3	Horizontal	0	1.5	-
2462MHz_TX	Pass	AV	432.02M	-62.72	-36.00	-26.72	5.76	3	Horizontal	0	1.5	-
2462MHz_TX	Pass	AV	528.03M	-60.62	-54.00	-6.62	7.75	3	Horizontal	0	1.5	-

**802.11n HT40\_Nss1,(MCS0)\_1TX**  
**2462MHz\_TX**

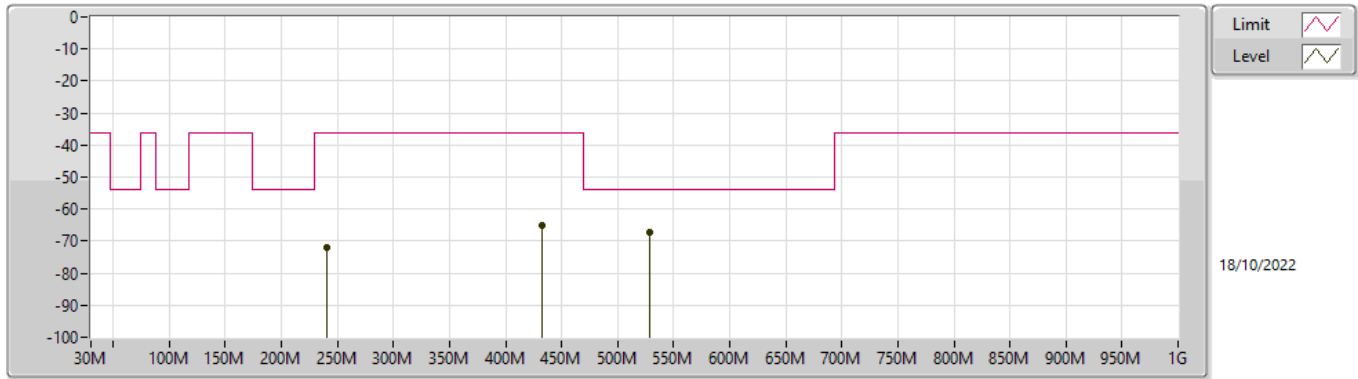

Freq (Hz)	Level (dBm)	Limit (dBm)	Margin (dB)	Factor (dB)	Condition	Raw (dBm)
240.01M	-72.06	-36.00	-36.06	0.32	Vertical	-72.38
432.02M	-65.21	-36.00	-29.21	5.09	Vertical	-70.30
528.03M	-67.21	-54.00	-13.21	6.73	Vertical	-73.94

**802.11n HT40\_Nss1,(MCS0)\_1TX**  
**2462MHz\_TX**

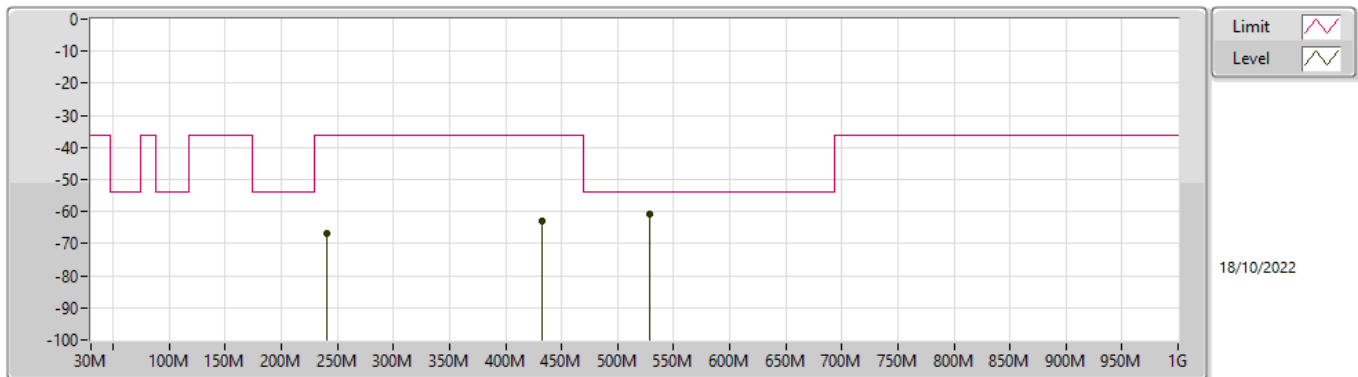

Freq (Hz)	Level (dBm)	Limit (dBm)	Margin (dB)	Factor (dB)	Condition	Raw (dBm)
240.01M	-66.86	-36.00	-30.86	1.16	Horizontal	-68.02
432.02M	-62.72	-36.00	-26.72	5.76	Horizontal	-68.48
528.03M	-60.62	-54.00	-6.62	7.75	Horizontal	-68.37



Summary

Mode	Result	Type	Freq (Hz)	Level (dBm)	Limit (dBm)	Margin (dB)	Factor (dB)	Dist (m)	Condition	Azimuth (°)	Height (m)	Comments
2.4-2.4835GHz	-	-	-	-	-	-	-	-	-	-	-	-
802.11b_Nss1,(1Mbps)_1TX	Pass	AV	9.88794G	-40.14	-30.00	-10.14	7.25	3	Vertical	360	1.5	-
802.11g_Nss1,(6Mbps)_1TX	Pass	AV	9.88462G	-47.57	-30.00	-17.57	7.25	3	Vertical	360	1.5	-
802.11n HT20_Nss1,(MCS0)_1TX	Pass	AV	9.87964G	-49.73	-30.00	-19.73	7.25	3	Vertical	0	1.5	-
802.11n HT40_Nss1,(MCS0)_1TX	Pass	AV	9.8423G	-49.61	-30.00	-19.61	7.24	3	Vertical	360	1.5	-



Result

Mode	Result	Type	Freq (Hz)	Level (dBm)	Limit (dBm)	Margin (dB)	Factor (dB)	Dist (m)	Condition	Azimuth (°)	Height (m)	Comments
802.11b_Nss1,(1Mbps)_1TX	-	-	-	-	-	-	-	-	-	-	-	-
2412MHz_TX	Pass	AV	4.82395G	-44.01	-30.00	-14.01	3.98	3	Vertical	0	1.5	-
2412MHz_TX	Pass	AV	7.23417G	-50.77	-30.00	-20.77	6.58	3	Vertical	0	1.5	-
2412MHz_TX	Pass	AV	9.64812G	-44.25	-30.00	-14.25	7.19	3	Vertical	0	1.5	-
2412MHz_TX	Pass	AV	4.82395G	-46.94	-30.00	-16.94	2.91	3	Horizontal	360	1.5	-
2412MHz_TX	Pass	AV	7.23541G	-54.21	-30.00	-24.21	4.93	3	Horizontal	360	1.5	-
2412MHz_TX	Pass	AV	9.64812G	-50.63	-30.00	-20.63	4.12	3	Horizontal	360	1.5	-
2472MHz_TX	Pass	AV	4.94386G	-43.85	-30.00	-13.85	4.06	3	Vertical	360	1.5	-
2472MHz_TX	Pass	AV	7.41507G	-52.18	-30.00	-22.18	6.57	3	Vertical	360	1.5	-
2472MHz_TX	Pass	AV	9.88794G	-40.14	-30.00	-10.14	7.25	3	Vertical	360	1.5	-
2472MHz_TX	Pass	AV	4.94386G	-41.22	-30.00	-11.22	3.00	3	Horizontal	0	1.5	-
2472MHz_TX	Pass	AV	7.41756G	-53.46	-30.00	-23.46	4.67	3	Horizontal	0	1.5	-
2472MHz_TX	Pass	AV	9.88794G	-47.06	-30.00	-17.06	4.20	3	Horizontal	0	1.5	-
802.11g_Nss1,(6Mbps)_1TX	-	-	-	-	-	-	-	-	-	-	-	-
2412MHz_TX	Pass	AV	4.82354G	-52.89	-30.00	-22.89	3.98	3	Vertical	0	1.5	-
2412MHz_TX	Pass	AV	7.22836G	-51.08	-30.00	-21.08	6.58	3	Vertical	0	1.5	-
2412MHz_TX	Pass	AV	9.64356G	-50.29	-30.00	-20.29	7.19	3	Vertical	0	1.5	-
2412MHz_TX	Pass	AV	4.82354G	-54.44	-30.00	-24.44	2.91	3	Horizontal	360	1.5	-
2412MHz_TX	Pass	AV	7.24247G	-53.85	-30.00	-23.85	4.92	3	Horizontal	360	1.5	-
2412MHz_TX	Pass	AV	9.64854G	-54.61	-30.00	-24.61	4.12	3	Horizontal	360	1.5	-
2472MHz_TX	Pass	AV	4.94801G	-51.37	-30.00	-21.37	4.06	3	Vertical	360	1.5	-
2472MHz_TX	Pass	AV	7.41341G	-52.39	-30.00	-22.39	6.57	3	Vertical	360	1.5	-
2472MHz_TX	Pass	AV	9.88462G	-47.57	-30.00	-17.57	7.25	3	Vertical	360	1.5	-
2472MHz_TX	Pass	AV	4.94469G	-49.30	-30.00	-19.30	3.00	3	Horizontal	0	1.5	-
2472MHz_TX	Pass	AV	7.43291G	-53.72	-30.00	-23.72	4.65	3	Horizontal	0	1.5	-
2472MHz_TX	Pass	AV	9.88172G	-53.06	-30.00	-23.06	4.20	3	Horizontal	0	1.5	-
802.11n HT20_Nss1,(MCS0)_1TX	-	-	-	-	-	-	-	-	-	-	-	-
2412MHz_TX	Pass	AV	4.82727G	-52.63	-30.00	-22.63	3.98	3	Vertical	360	1.5	-
2412MHz_TX	Pass	AV	7.24247G	-51.68	-30.00	-21.68	6.58	3	Vertical	360	1.5	-
2412MHz_TX	Pass	AV	9.65144G	-50.43	-30.00	-20.43	7.19	3	Vertical	360	1.5	-
2412MHz_TX	Pass	AV	4.82644G	-55.36	-30.00	-25.36	2.92	3	Horizontal	0	1.5	-
2412MHz_TX	Pass	AV	7.24911G	-53.97	-30.00	-23.97	4.91	3	Horizontal	0	1.5	-
2412MHz_TX	Pass	AV	9.64397G	-55.23	-30.00	-25.23	4.12	3	Horizontal	0	1.5	-
2472MHz_TX	Pass	AV	4.94344G	-52.20	-30.00	-22.20	4.05	3	Vertical	0	1.5	-
2472MHz_TX	Pass	AV	7.41051G	-52.60	-30.00	-22.60	6.57	3	Vertical	0	1.5	-
2472MHz_TX	Pass	AV	9.87964G	-49.73	-30.00	-19.73	7.25	3	Vertical	0	1.5	-
2472MHz_TX	Pass	AV	4.94054G	-50.35	-30.00	-20.35	3.00	3	Horizontal	360	1.5	-
2472MHz_TX	Pass	AV	7.42129G	-54.60	-30.00	-24.60	4.66	3	Horizontal	360	1.5	-
2472MHz_TX	Pass	AV	9.87964G	-53.51	-30.00	-23.51	4.20	3	Horizontal	360	1.5	-
802.11n HT40_Nss1,(MCS0)_1TX	-	-	-	-	-	-	-	-	-	-	-	-
2422MHz_TX	Pass	AV	4.84926G	-54.61	-30.00	-24.61	4.00	3	Vertical	0	1.5	-
2422MHz_TX	Pass	AV	7.24164G	-52.09	-30.00	-22.09	6.58	3	Vertical	0	1.5	-
2422MHz_TX	Pass	AV	9.6697G	-51.43	-30.00	-21.43	7.19	3	Vertical	0	1.5	-
2422MHz_TX	Pass	AV	4.84013G	-56.30	-30.00	-26.30	2.92	3	Horizontal	360	1.5	-
2422MHz_TX	Pass	AV	7.29018G	-53.65	-30.00	-23.65	4.85	3	Horizontal	360	1.5	-
2422MHz_TX	Pass	AV	9.66182G	-54.52	-30.00	-24.52	4.13	3	Horizontal	360	1.5	-
2462MHz_TX	Pass	AV	4.92228G	-53.44	-30.00	-23.44	4.04	3	Vertical	360	1.5	-
2462MHz_TX	Pass	AV	7.3852G	-52.92	-30.00	-22.92	6.57	3	Vertical	360	1.5	-



Mode	Result	Type	Freq (Hz)	Level (dBm)	Limit (dBm)	Margin (dB)	Factor (dB)	Dist (m)	Condition	Azimuth (°)	Height (m)	Comments
2462MHz_TX	Pass	AV	9.8423G	-49.61	-30.00	-19.61	7.24	3	Vertical	360	1.5	-
2462MHz_TX	Pass	AV	4.92353G	-52.21	-30.00	-22.21	2.98	3	Horizontal	0	1.5	-
2462MHz_TX	Pass	AV	7.39557G	-54.21	-30.00	-24.21	4.70	3	Horizontal	0	1.5	-
2462MHz_TX	Pass	AV	9.85309G	-54.78	-30.00	-24.78	4.19	3	Horizontal	0	1.5	-

**802.11b\_Nss1,(1Mbps)\_1TX**  
**2412MHz\_TX**

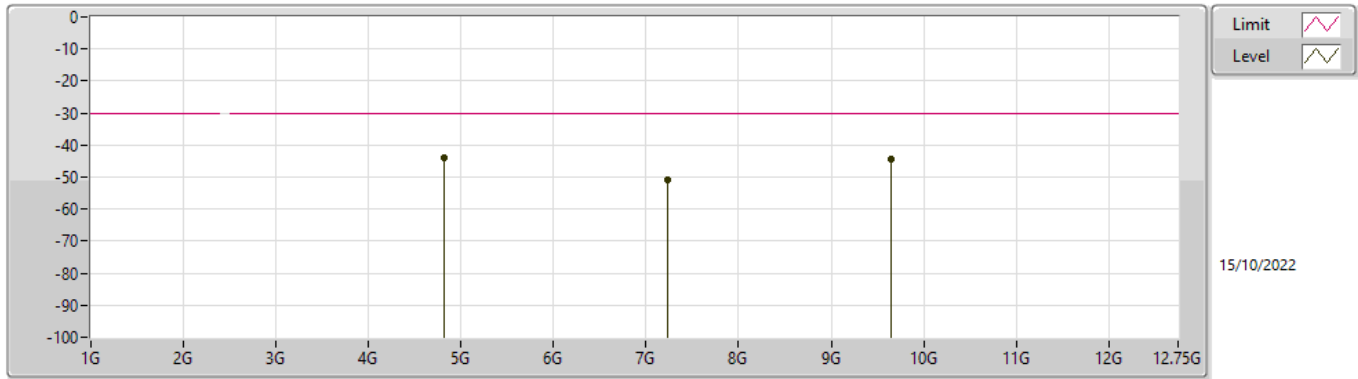

Freq (Hz)	Level (dBm)	Limit (dBm)	Margin (dB)	Factor (dB)	Condition	Raw (dBm)
4.82395G	-44.01	-30.00	-14.01	3.98	Vertical	-47.99
7.23417G	-50.77	-30.00	-20.77	6.58	Vertical	-57.35
9.64812G	-44.25	-30.00	-14.25	7.19	Vertical	-51.44

**802.11b\_Nss1,(1Mbps)\_1TX**  
**2412MHz\_TX**

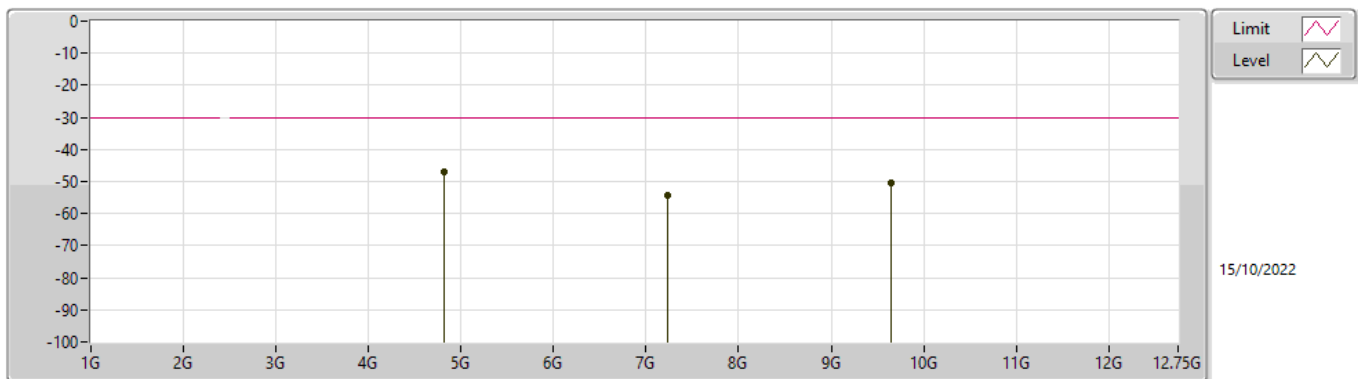

Freq (Hz)	Level (dBm)	Limit (dBm)	Margin (dB)	Factor (dB)	Condition	Raw (dBm)
4.82395G	-46.94	-30.00	-16.94	2.91	Horizontal	-49.85
7.23541G	-54.21	-30.00	-24.21	4.93	Horizontal	-59.14
9.64812G	-50.63	-30.00	-20.63	4.12	Horizontal	-54.75

**802.11b\_Nss1,(1Mbps)\_1TX**  
**2472MHz\_TX**

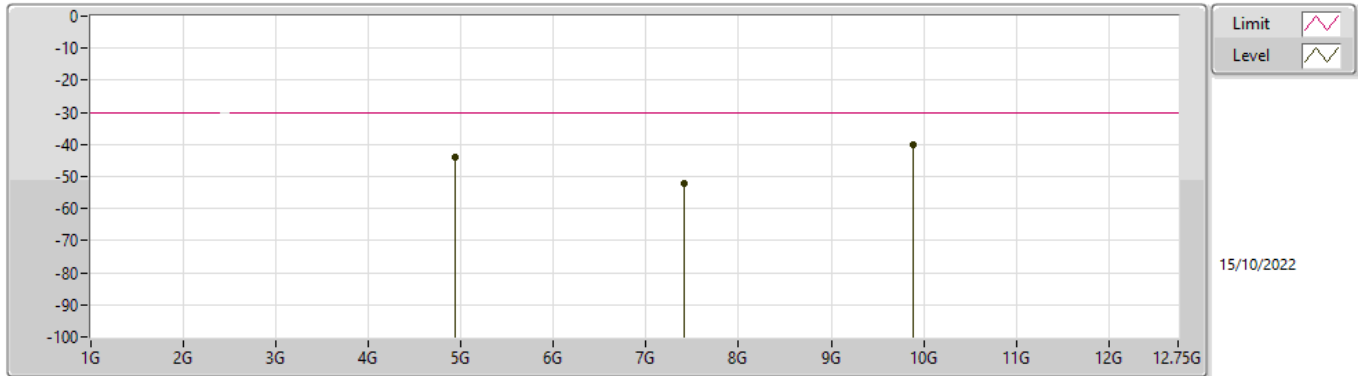

Freq (Hz)	Level (dBm)	Limit (dBm)	Margin (dB)	Factor (dB)	Condition	Raw (dBm)
4.94386G	-43.85	-30.00	-13.85	4.06	Vertical	-47.91
7.41507G	-52.18	-30.00	-22.18	6.57	Vertical	-58.75
9.88794G	-40.14	-30.00	-10.14	7.25	Vertical	-47.39

**802.11b\_Nss1,(1Mbps)\_1TX**  
**2472MHz\_TX**

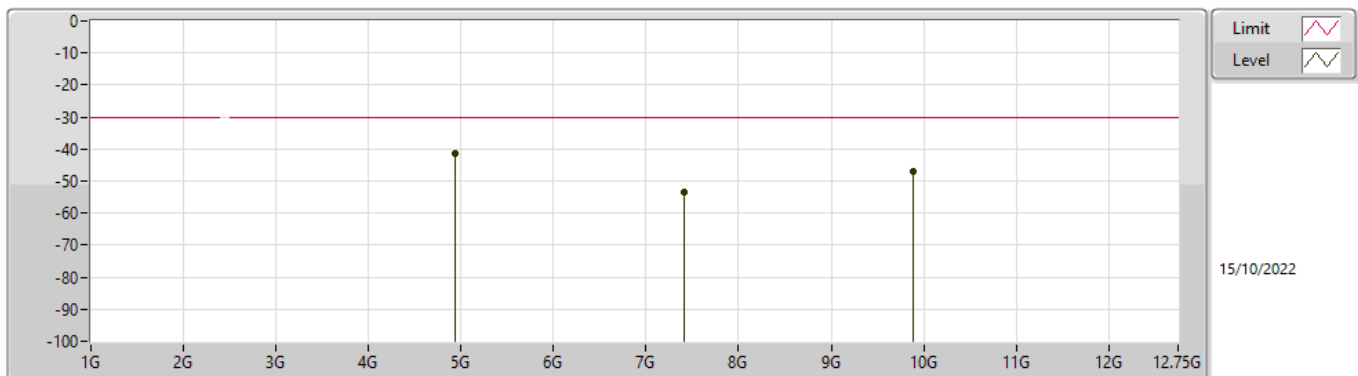

Freq (Hz)	Level (dBm)	Limit (dBm)	Margin (dB)	Factor (dB)	Condition	Raw (dBm)
4.94386G	-41.22	-30.00	-11.22	3.00	Horizontal	-44.22
7.41756G	-53.46	-30.00	-23.46	4.67	Horizontal	-58.13
9.88794G	-47.06	-30.00	-17.06	4.20	Horizontal	-51.26

**802.11g\_Nss1,(6Mbps)\_1TX**  
**2412MHz\_TX**

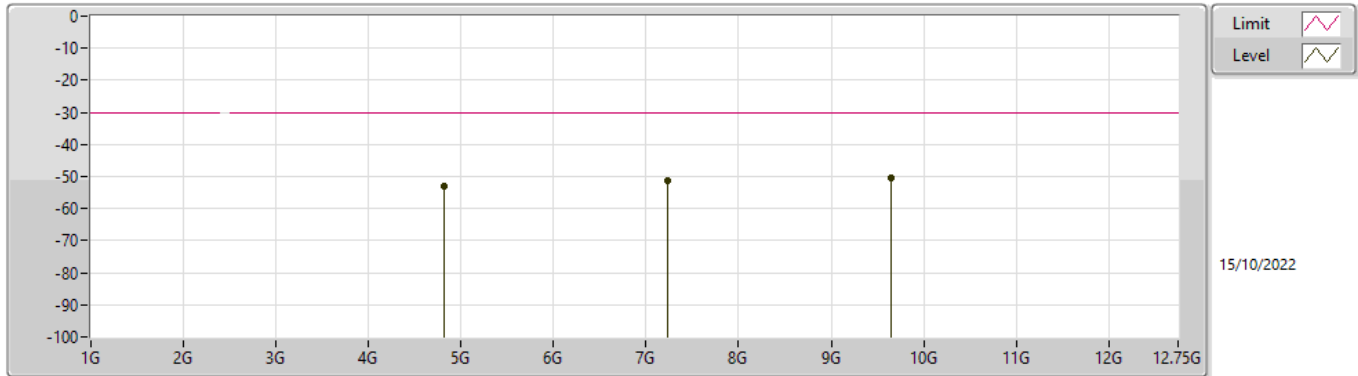

Freq (Hz)	Level (dBm)	Limit (dBm)	Margin (dB)	Factor (dB)	Condition	Raw (dBm)
4.82354G	-52.89	-30.00	-22.89	3.98	Vertical	-56.87
7.22836G	-51.08	-30.00	-21.08	6.58	Vertical	-57.66
9.64356G	-50.29	-30.00	-20.29	7.19	Vertical	-57.48

**802.11g\_Nss1,(6Mbps)\_1TX**  
**2412MHz\_TX**

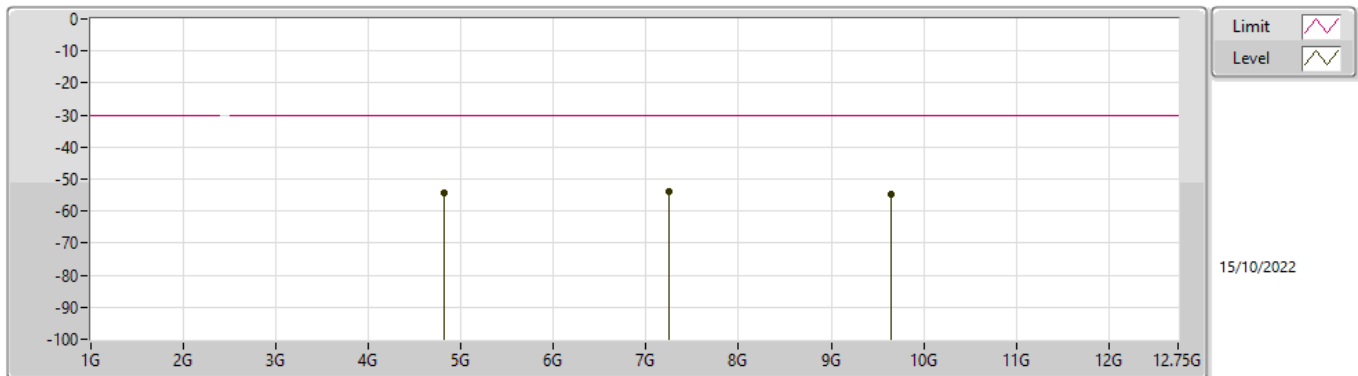

Freq (Hz)	Level (dBm)	Limit (dBm)	Margin (dB)	Factor (dB)	Condition	Raw (dBm)
4.82354G	-54.44	-30.00	-24.44	2.91	Horizontal	-57.35
7.24247G	-53.85	-30.00	-23.85	4.92	Horizontal	-58.77
9.64854G	-54.61	-30.00	-24.61	4.12	Horizontal	-58.73

**802.11g\_Nss1,(6Mbps)\_1TX**  
**2472MHz\_TX**

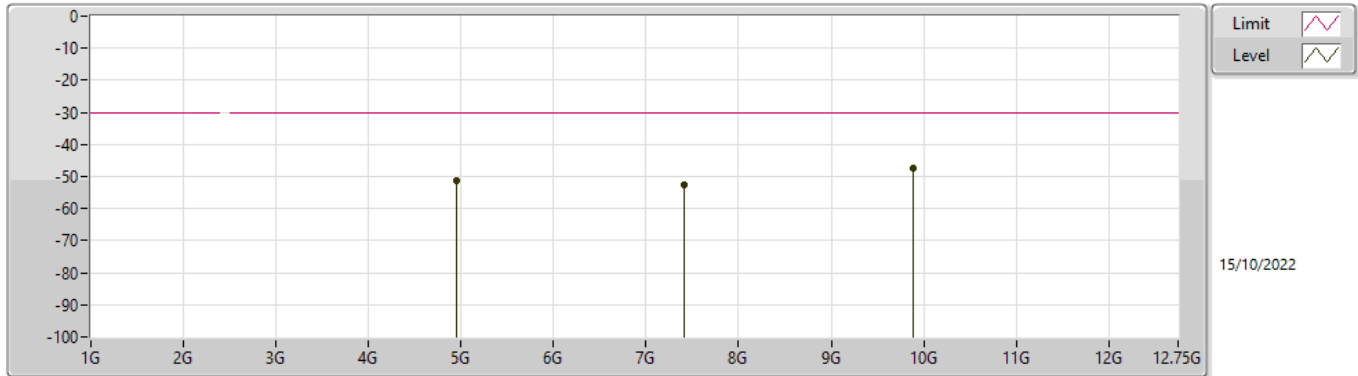

Freq (Hz)	Level (dBm)	Limit (dBm)	Margin (dB)	Factor (dB)	Condition	Raw (dBm)
4.94801G	-51.37	-30.00	-21.37	4.06	Vertical	-55.43
7.41341G	-52.39	-30.00	-22.39	6.57	Vertical	-58.96
9.88462G	-47.57	-30.00	-17.57	7.25	Vertical	-54.82

**802.11g\_Nss1,(6Mbps)\_1TX**  
**2472MHz\_TX**

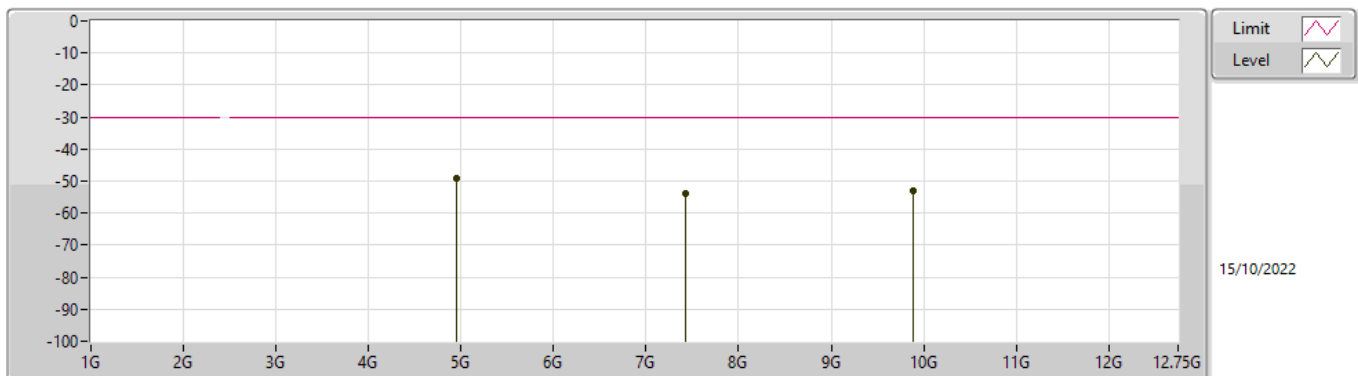

Freq (Hz)	Level (dBm)	Limit (dBm)	Margin (dB)	Factor (dB)	Condition	Raw (dBm)
4.94469G	-49.30	-30.00	-19.30	3.00	Horizontal	-52.30
7.43291G	-53.72	-30.00	-23.72	4.65	Horizontal	-58.37
9.88172G	-53.06	-30.00	-23.06	4.20	Horizontal	-57.26

**802.11n HT20\_Nss1,(MCS0)\_1TX**  
**2412MHz\_TX**

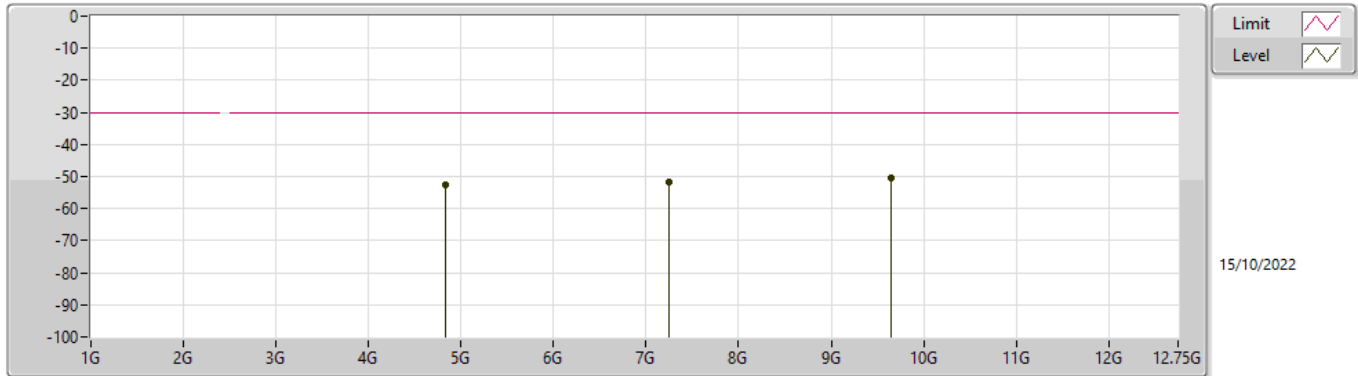

Freq (Hz)	Level (dBm)	Limit (dBm)	Margin (dB)	Factor (dB)	Condition	Raw (dBm)
4.82727G	-52.63	-30.00	-22.63	3.98	Vertical	-56.61
7.24247G	-51.68	-30.00	-21.68	6.58	Vertical	-58.26
9.65144G	-50.43	-30.00	-20.43	7.19	Vertical	-57.62

**802.11n HT20\_Nss1,(MCS0)\_1TX**  
**2412MHz\_TX**

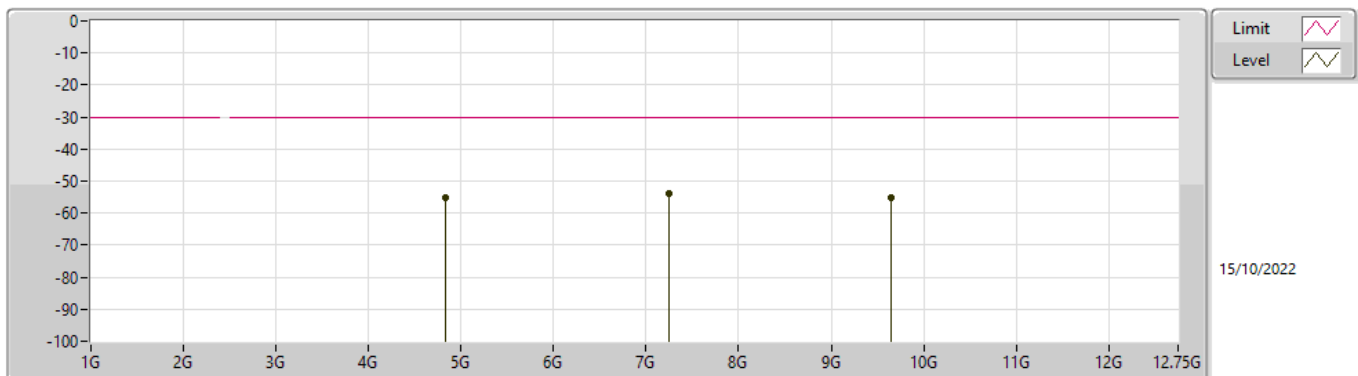

Freq (Hz)	Level (dBm)	Limit (dBm)	Margin (dB)	Factor (dB)	Condition	Raw (dBm)
4.82644G	-55.36	-30.00	-25.36	2.92	Horizontal	-58.28
7.24911G	-53.97	-30.00	-23.97	4.91	Horizontal	-58.88
9.64397G	-55.23	-30.00	-25.23	4.12	Horizontal	-59.35

**802.11n HT20\_Nss1,(MCS0)\_1TX**  
**2472MHz\_TX**

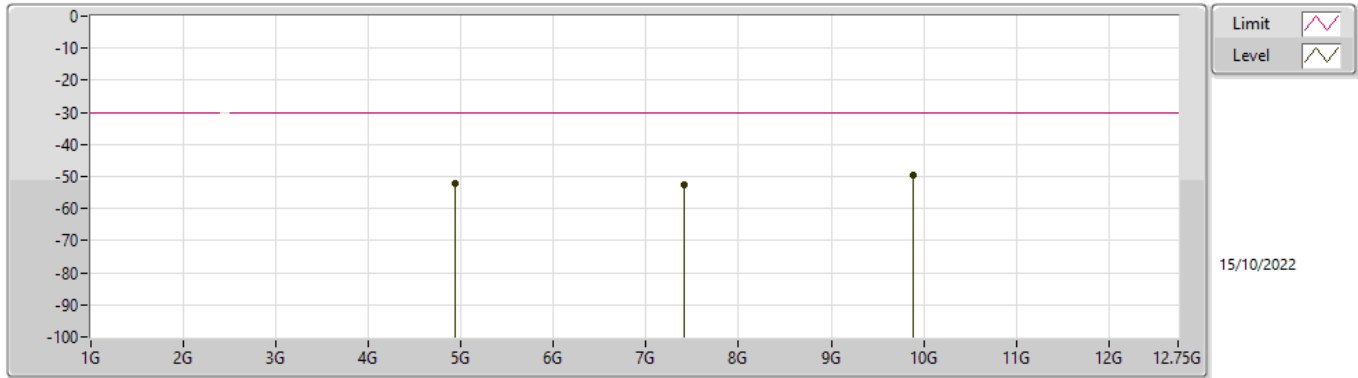

Freq (Hz)	Level (dBm)	Limit (dBm)	Margin (dB)	Factor (dB)	Condition	Raw (dBm)
4.94344G	-52.20	-30.00	-22.20	4.05	Vertical	-56.25
7.41051G	-52.60	-30.00	-22.60	6.57	Vertical	-59.17
9.87964G	-49.73	-30.00	-19.73	7.25	Vertical	-56.98

**802.11n HT20\_Nss1,(MCS0)\_1TX**  
**2472MHz\_TX**

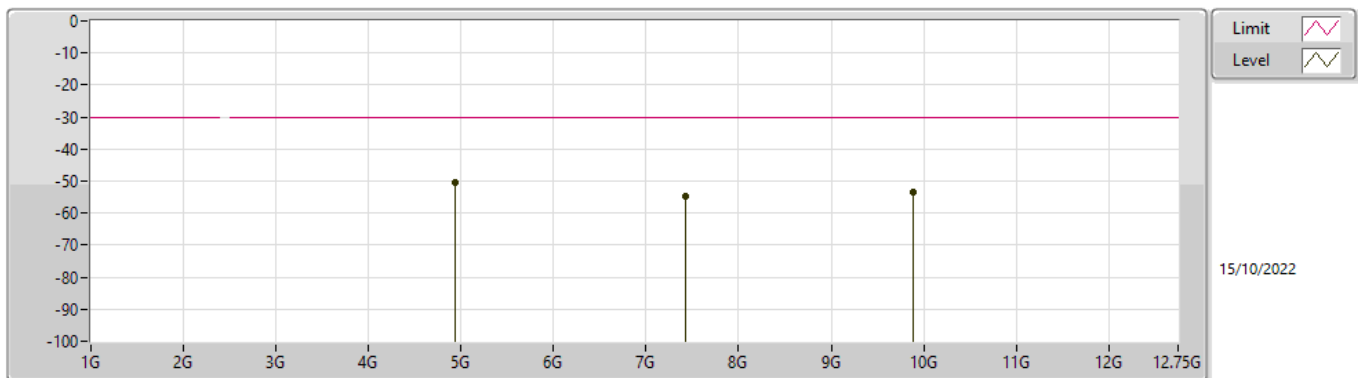

Freq (Hz)	Level (dBm)	Limit (dBm)	Margin (dB)	Factor (dB)	Condition	Raw (dBm)
4.94054G	-50.35	-30.00	-20.35	3.00	Horizontal	-53.35
7.42129G	-54.60	-30.00	-24.60	4.66	Horizontal	-59.26
9.87964G	-53.51	-30.00	-23.51	4.20	Horizontal	-57.71

**802.11n HT40\_Nss1,(MCS0)\_1TX**  
**2422MHz\_TX**

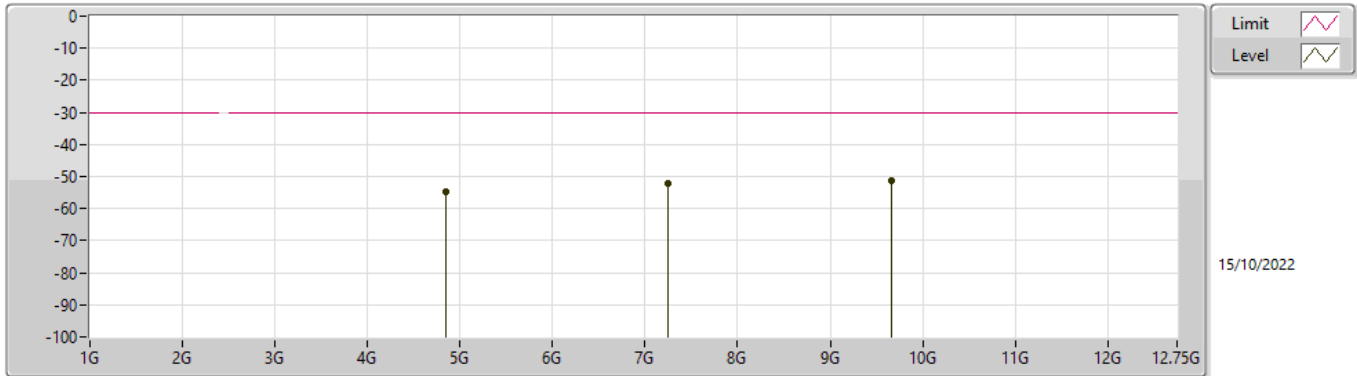

Freq (Hz)	Level (dBm)	Limit (dBm)	Margin (dB)	Factor (dB)	Condition	Raw (dBm)
4.84926G	-54.61	-30.00	-24.61	4.00	Vertical	-58.61
7.24164G	-52.09	-30.00	-22.09	6.58	Vertical	-58.67
9.6697G	-51.43	-30.00	-21.43	7.19	Vertical	-58.62

**802.11n HT40\_Nss1,(MCS0)\_1TX**  
**2422MHz\_TX**

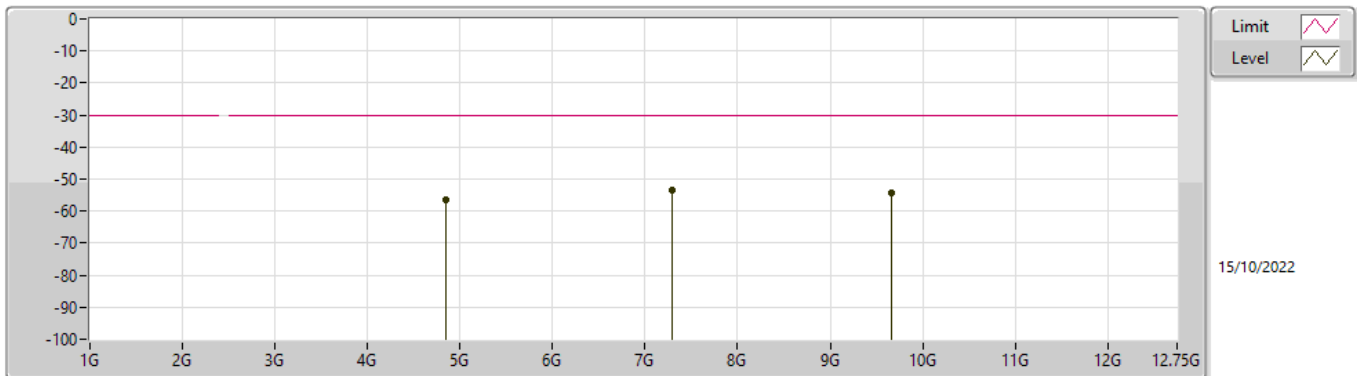

Freq (Hz)	Level (dBm)	Limit (dBm)	Margin (dB)	Factor (dB)	Condition	Raw (dBm)
4.84013G	-56.30	-30.00	-26.30	2.92	Horizontal	-59.22
7.29018G	-53.65	-30.00	-23.65	4.85	Horizontal	-58.50
9.66182G	-54.52	-30.00	-24.52	4.13	Horizontal	-58.65

**802.11n HT40\_Nss1,(MCS0)\_1TX**  
**2462MHz\_TX**

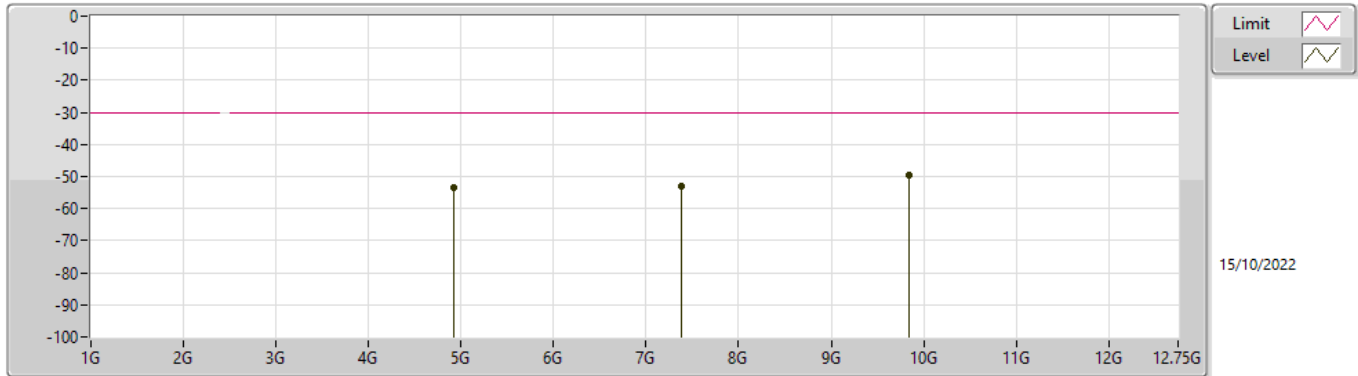

Freq (Hz)	Level (dBm)	Limit (dBm)	Margin (dB)	Factor (dB)	Condition	Raw (dBm)
4.92228G	-53.44	-30.00	-23.44	4.04	Vertical	-57.48
7.3852G	-52.92	-30.00	-22.92	6.57	Vertical	-59.49
9.8423G	-49.61	-30.00	-19.61	7.24	Vertical	-56.85

**802.11n HT40\_Nss1,(MCS0)\_1TX**  
**2462MHz\_TX**

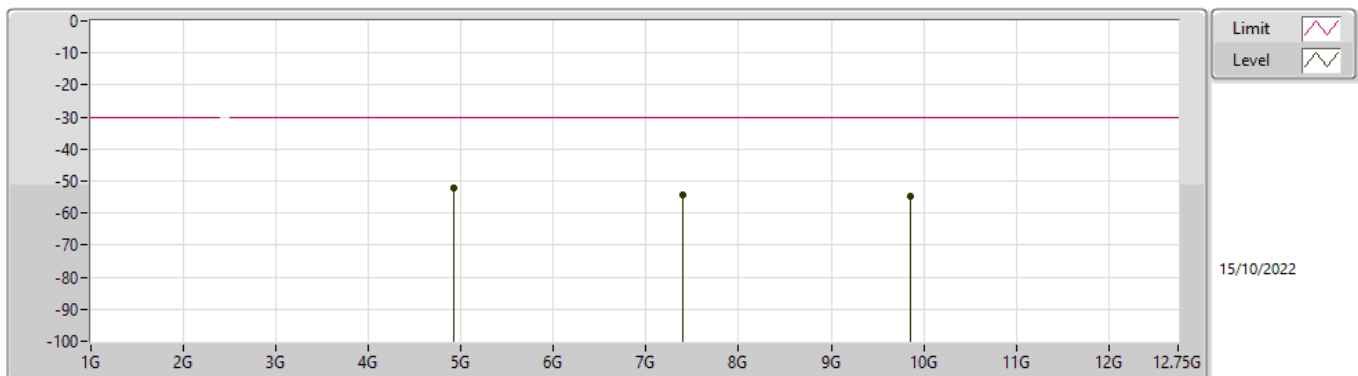

Freq (Hz)	Level (dBm)	Limit (dBm)	Margin (dB)	Factor (dB)	Condition	Raw (dBm)
4.92353G	-52.21	-30.00	-22.21	2.98	Horizontal	-55.19
7.39557G	-54.21	-30.00	-24.21	4.70	Horizontal	-58.91
9.85309G	-54.78	-30.00	-24.78	4.19	Horizontal	-58.97



Summary

Mode	Result	Type	Freq (Hz)	Level (dBm)	Limit (dBm)	Margin (dB)	Factor (dB)	Dist (m)	Condition	Azimuth (°)	Height (m)	Comments
2.4-2.4835GHz	-	-	-	-	-	-	-	-	-	-	-	-
802.11n HT40_(MCS0)_RX	Pass	AV	432M	-63.06	-57.00	-6.06	5.76	3	Horizontal	3	1.5	TDP

Result

Mode	Result	Type	Freq (Hz)	Level (dBm)	Limit (dBm)	Margin (dB)	Factor (dB)	Dist (m)	Condition	Azimuth (°)	Height (m)	Comments
802.11n HT40_(MCS0)_RX	-	-	-	-	-	-	-	-	-	-	-	-
2462MHz_RX	Pass	AV	68.2M	-67.13	-57.00	-10.13	-5.72	3	Vertical	360	1.5	-
2462MHz_RX	Pass	AV	240.01M	-71.27	-57.00	-14.27	0.32	3	Vertical	360	1.5	-
2462MHz_RX	Pass	AV	431.97M	-65.89	-57.00	-8.89	5.09	3	Vertical	360	1.5	-
2462MHz_RX	Pass	AV	240.01M	-64.97	-57.00	-7.97	1.16	3	Horizontal	0	1.5	-
2462MHz_RX	Pass	AV	432M	-63.06	-57.00	-6.06	5.76	3	Horizontal	3	1.5	TDP
2462MHz_RX	Pass	AV	528.01M	-63.08	-57.00	-6.08	7.75	3	Horizontal	47	1.5	TDP

**802.11n HT40\_(MCS0)\_RX**  
**2462MHz\_RX**

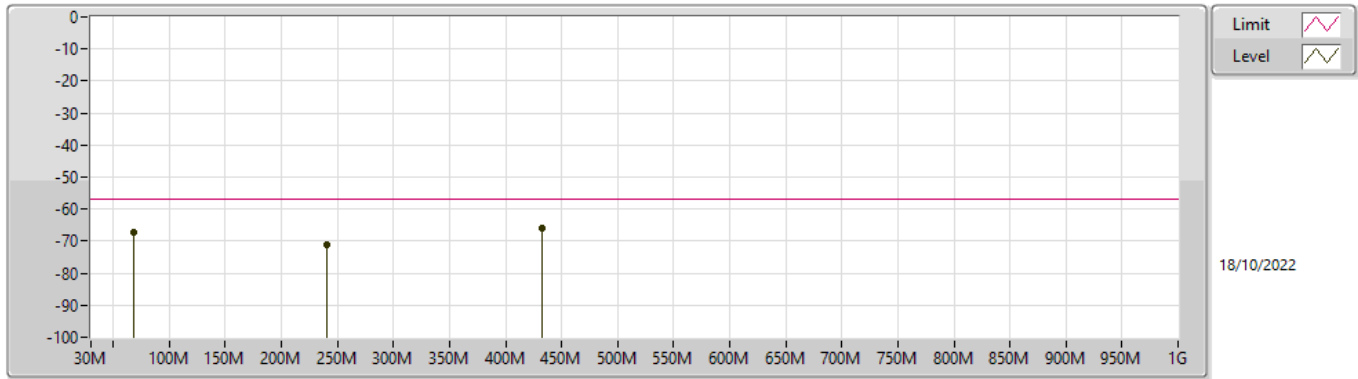

Freq (Hz)	Level (dBm)	Limit (dBm)	Margin (dB)	Factor (dB)	Condition	Raw (dBm)
68.2M	-67.13	-57.00	-10.13	-5.72	Vertical	-61.41
240.01M	-71.27	-57.00	-14.27	0.32	Vertical	-71.59
431.97M	-65.89	-57.00	-8.89	5.09	Vertical	-70.98

**802.11n HT40\_(MCS0)\_RX**  
**2462MHz\_RX**

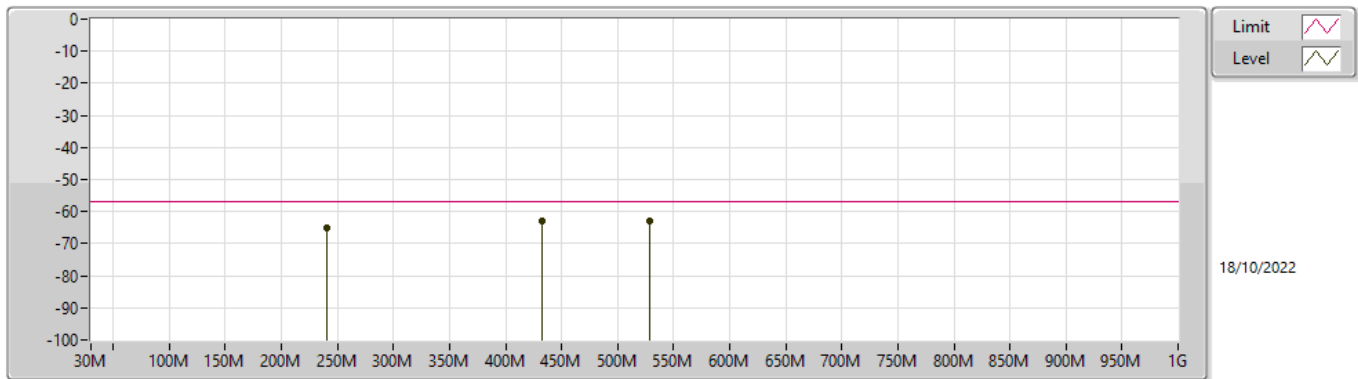

Freq (Hz)	Level (dBm)	Limit (dBm)	Margin (dB)	Factor (dB)	Condition	Raw (dBm)
240.01M	-64.97	-57.00	-7.97	1.16	Horizontal	-66.13
432M	-63.06	-57.00	-6.06	5.76	Horizontal	-68.82
528.01M	-63.08	-57.00	-6.08	7.75	Horizontal	-70.83



Summary

Mode	Result	Type	Freq (Hz)	Level (dBm)	Limit (dBm)	Margin (dB)	Factor (dB)	Dist (m)	Condition	Azimuth (°)	Height (m)	Comments
2.4-2.4835GHz	-	-	-	-	-	-	-	-	-	-	-	-
802.11n HT40_(MCS0)_RX	Pass	AV	5.99921G	-53.64	-47.00	-6.64	5.44	3	Vertical	360	1.5	-

Result

Mode	Result	Type	Freq (Hz)	Level (dBm)	Limit (dBm)	Margin (dB)	Factor (dB)	Dist (m)	Condition	Azimuth (°)	Height (m)	Comments
802.11n HT40_(MCS0)_RX	-	-	-	-	-	-	-	-	-	-	-	-
2422MHz_RX	Pass	AV	3.2291G	-58.54	-47.00	-11.54	0.58	3	Vertical	0	1.5	-
2422MHz_RX	Pass	AV	4.35564G	-55.62	-47.00	-8.62	3.38	3	Vertical	0	1.5	-
2422MHz_RX	Pass	AV	6.70974G	-53.66	-47.00	-6.66	5.97	3	Vertical	0	1.5	-
2422MHz_RX	Pass	AV	2.15955G	-59.45	-47.00	-12.45	-1.58	3	Horizontal	360	1.5	-
2422MHz_RX	Pass	AV	4.04713G	-57.67	-47.00	-10.67	1.69	3	Horizontal	360	1.5	-
2422MHz_RX	Pass	AV	6.79075G	-53.87	-47.00	-6.87	5.23	3	Horizontal	360	1.5	-
2462MHz_RX	Pass	AV	3.2291G	-58.07	-47.00	-11.07	0.58	3	Vertical	360	1.5	-
2462MHz_RX	Pass	AV	5.36519G	-55.54	-47.00	-8.54	4.24	3	Vertical	360	1.5	-
2462MHz_RX	Pass	AV	5.99921G	-53.64	-47.00	-6.64	5.44	3	Vertical	360	1.5	-
2462MHz_RX	Pass	AV	3.4366G	-58.69	-47.00	-11.69	0.56	3	Horizontal	0	1.5	-
2462MHz_RX	Pass	AV	4.11113G	-56.78	-47.00	-9.78	1.83	3	Horizontal	0	1.5	-
2462MHz_RX	Pass	AV	6.76875G	-54.32	-47.00	-7.32	5.22	3	Horizontal	0	1.5	-

**802.11n HT40\_(MCS0)\_RX**  
**2422MHz\_RX**

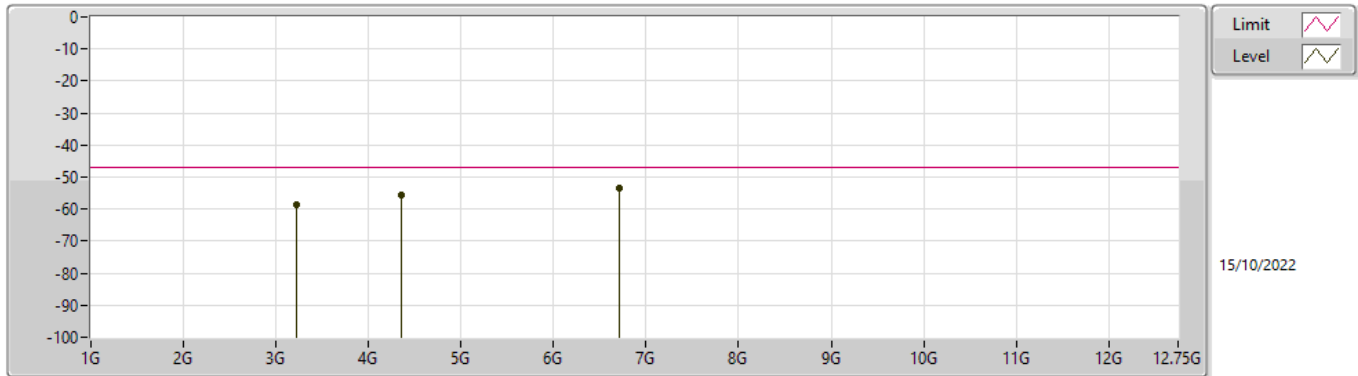

Freq (Hz)	Level (dBm)	Limit (dBm)	Margin (dB)	Factor (dB)	Condition	Raw (dBm)
3.2291G	-58.54	-47.00	-11.54	0.58	Vertical	-59.12
4.35564G	-55.62	-47.00	-8.62	3.38	Vertical	-59.00
6.70974G	-53.66	-47.00	-6.66	5.97	Vertical	-59.63

**802.11n HT40\_(MCS0)\_RX**  
**2422MHz\_RX**

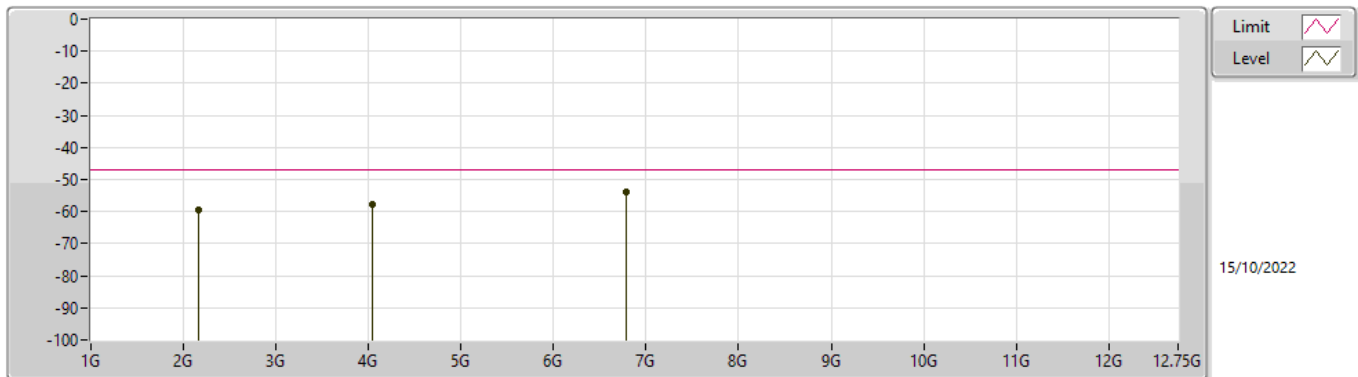

Freq (Hz)	Level (dBm)	Limit (dBm)	Margin (dB)	Factor (dB)	Condition	Raw (dBm)
2.15955G	-59.45	-47.00	-12.45	-1.58	Horizontal	-57.87
4.04713G	-57.67	-47.00	-10.67	1.69	Horizontal	-59.36
6.79075G	-53.87	-47.00	-6.87	5.23	Horizontal	-59.10

**802.11n HT40\_(MCS0)\_RX**  
**2462MHz\_RX**

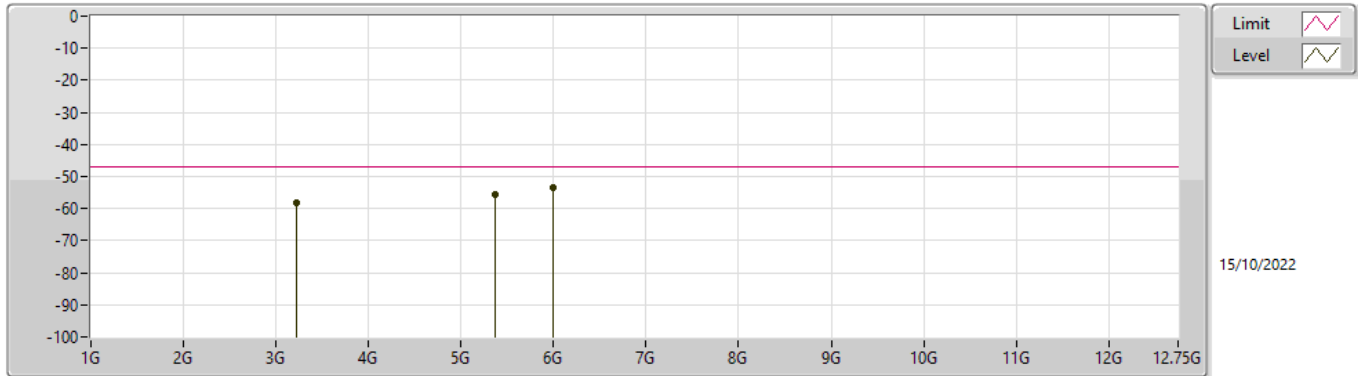

Freq (Hz)	Level (dBm)	Limit (dBm)	Margin (dB)	Factor (dB)	Condition	Raw (dBm)
3.2291G	-58.07	-47.00	-11.07	0.58	Vertical	-58.65
5.36519G	-55.54	-47.00	-8.54	4.24	Vertical	-59.78
5.99921G	-53.64	-47.00	-6.64	5.44	Vertical	-59.08

**802.11n HT40\_(MCS0)\_RX**  
**2462MHz\_RX**

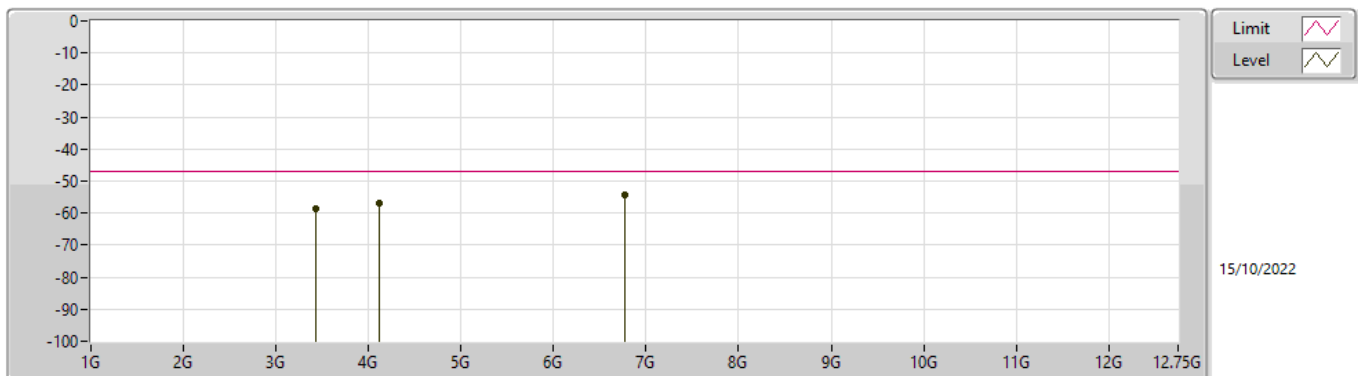

Freq (Hz)	Level (dBm)	Limit (dBm)	Margin (dB)	Factor (dB)	Condition	Raw (dBm)
3.4366G	-58.69	-47.00	-11.69	0.56	Horizontal	-59.25
4.11113G	-56.78	-47.00	-9.78	1.83	Horizontal	-58.61
6.76875G	-54.32	-47.00	-7.32	5.22	Horizontal	-59.54



Adaptivity Result						
Adaptivity Detection Threshold Level		-70 dBm/MHz				
Unwanted Signal Level		-32.6 dBm				
Modulation Mode	Freq. (MHz)	Adaptivity	Unwanted Signal Test Status	Short Control Signaling Transmissions (ms)	Channel Occupancy Time (ms)	Idle Period (us)
802.11b	2412	Pass	Pass	0.000	0.250	63.000
802.11b	2472	Pass	Pass	0.000	0.250	47.000
802.11g	2412	Pass	Pass	0.000	0.650	43.000
802.11g	2472	Pass	Pass	0.000	0.649	42.000
802.11n (HT20)	2412	Pass	Pass	0.000	0.782	61.000
802.11n (HT20)	2472	Pass	Pass	0.000	0.920	52.000
802.11n (HT40)	2422	Pass	Pass	0.000	1.357	60.000
802.11n (HT40)	2462	Pass	Pass	0.000	1.357	42.000
<b>Limit</b>		N/A	N/A	5	N/A	N/A
<b>Result</b>		<b>Complied</b>				
Note: Channel Occupancy Time and Idle Period Time follow as IEEE 802.11™ [i.3] clause 10, clause 11, clause 15, clause 16, clause 18 and clause 19 specification without restriction.						

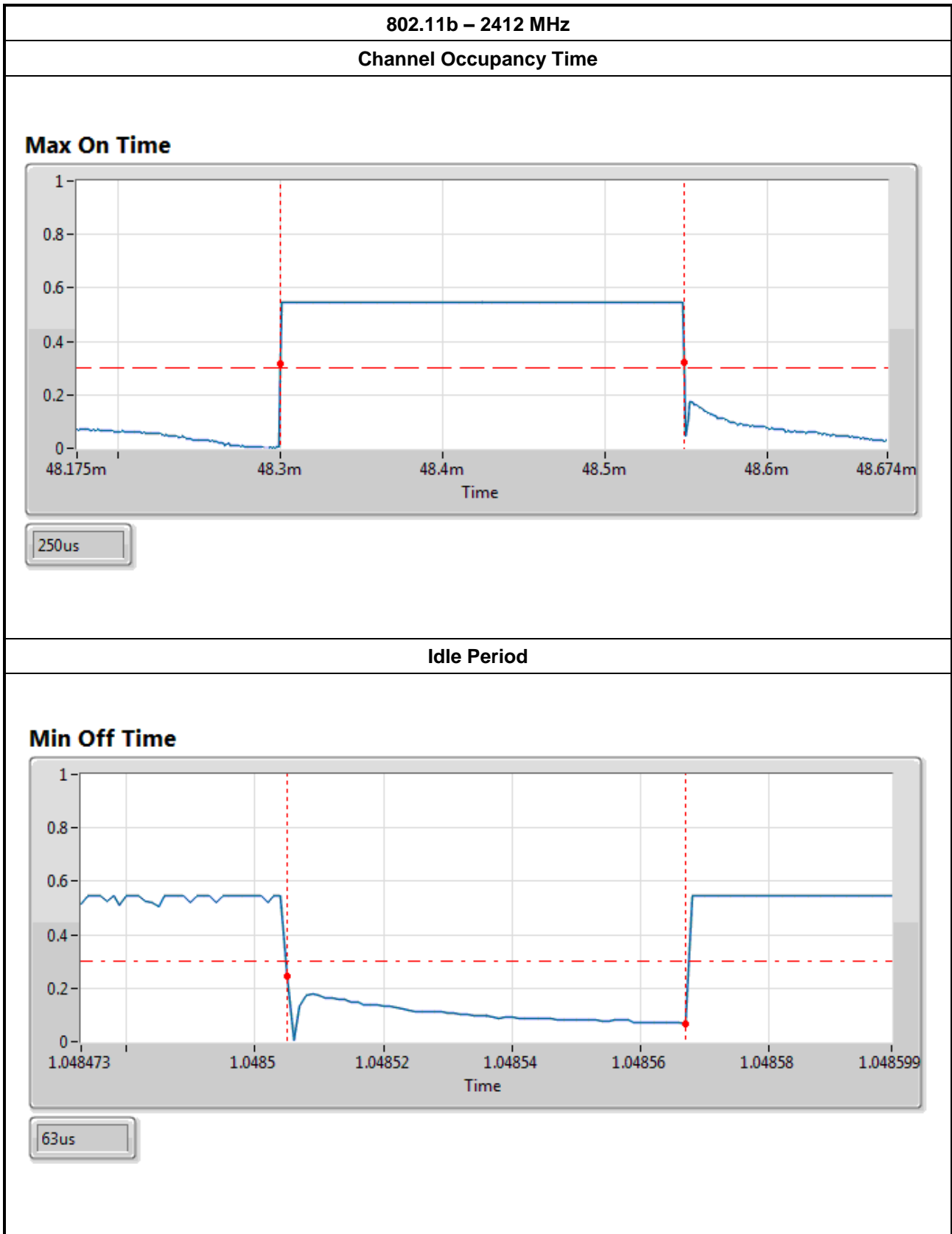

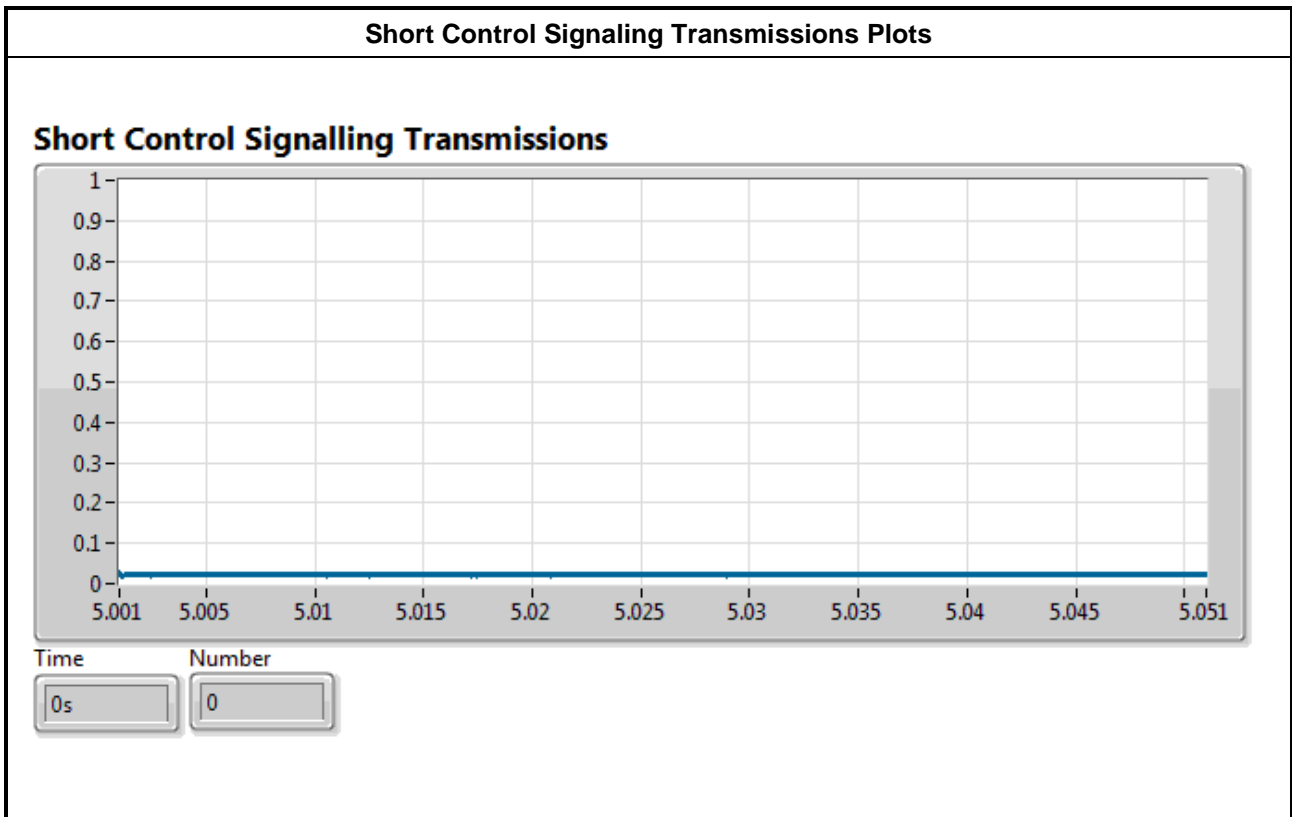
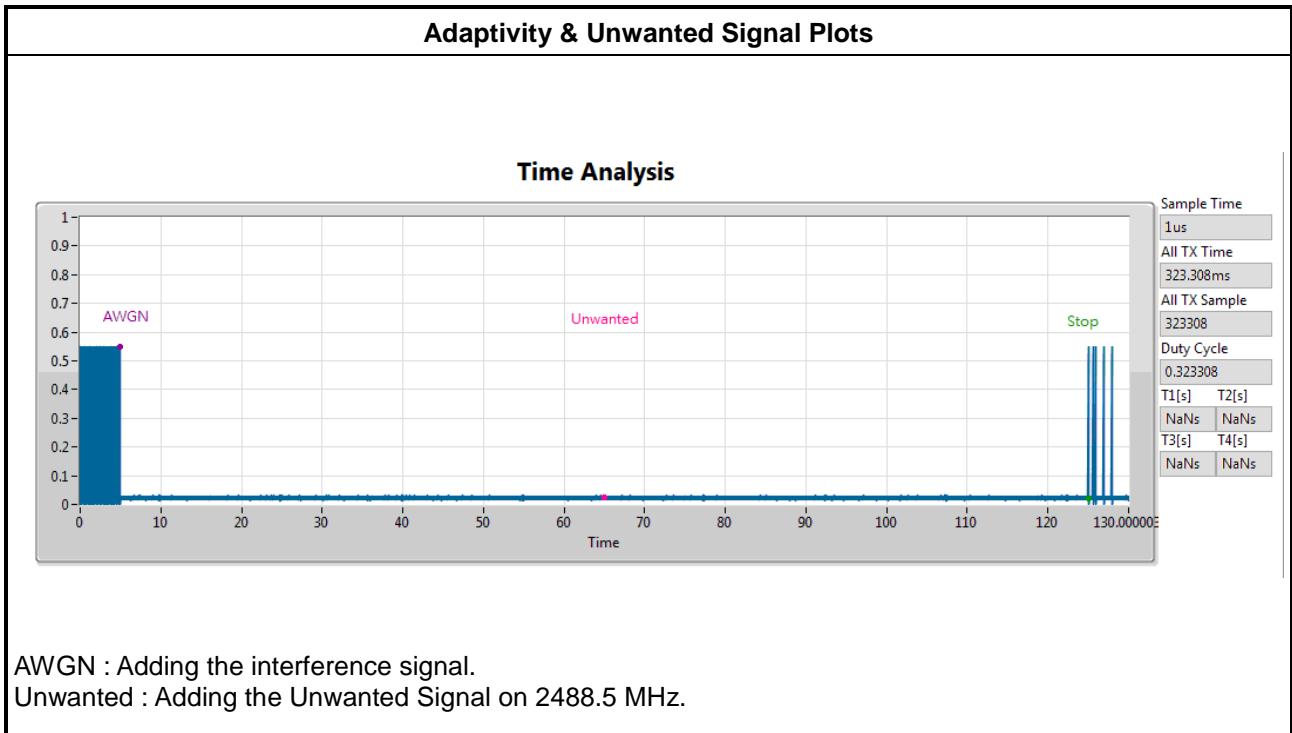



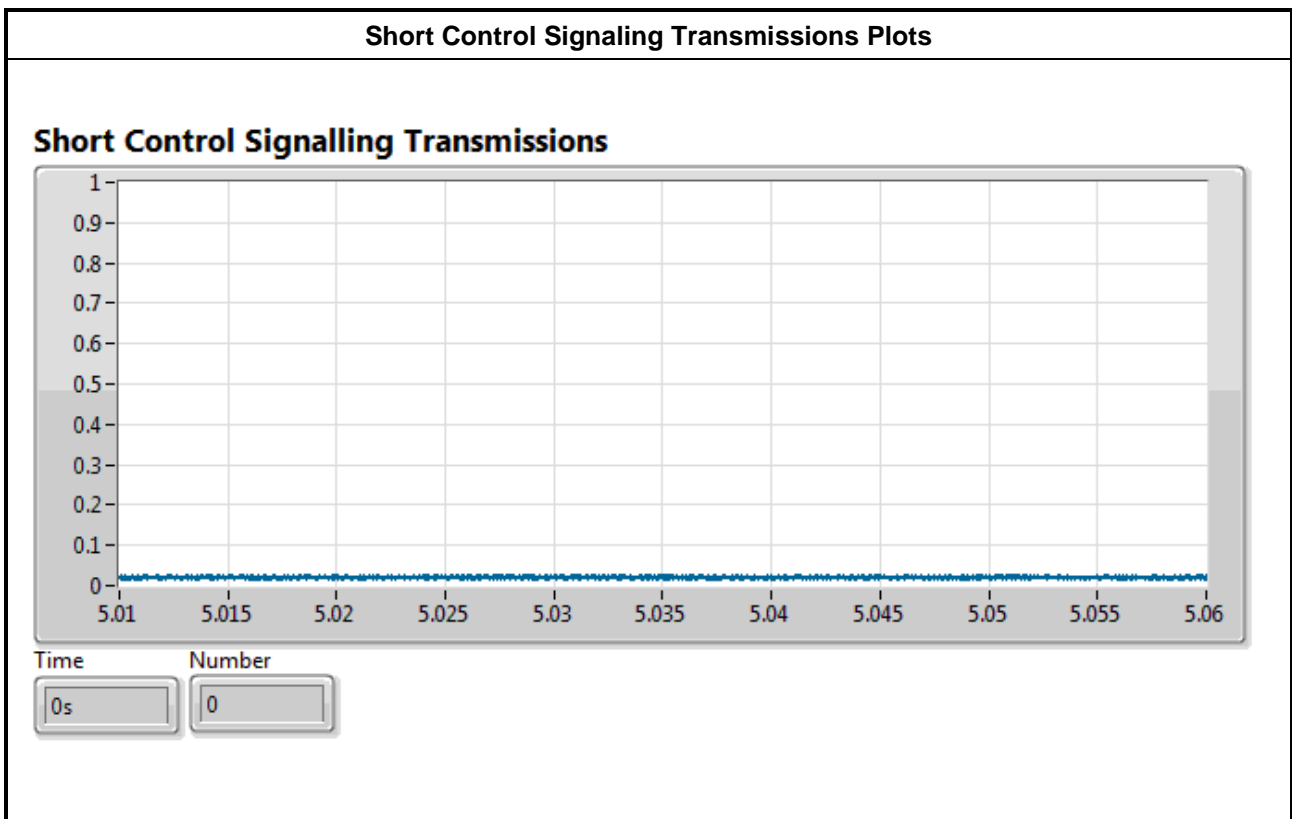
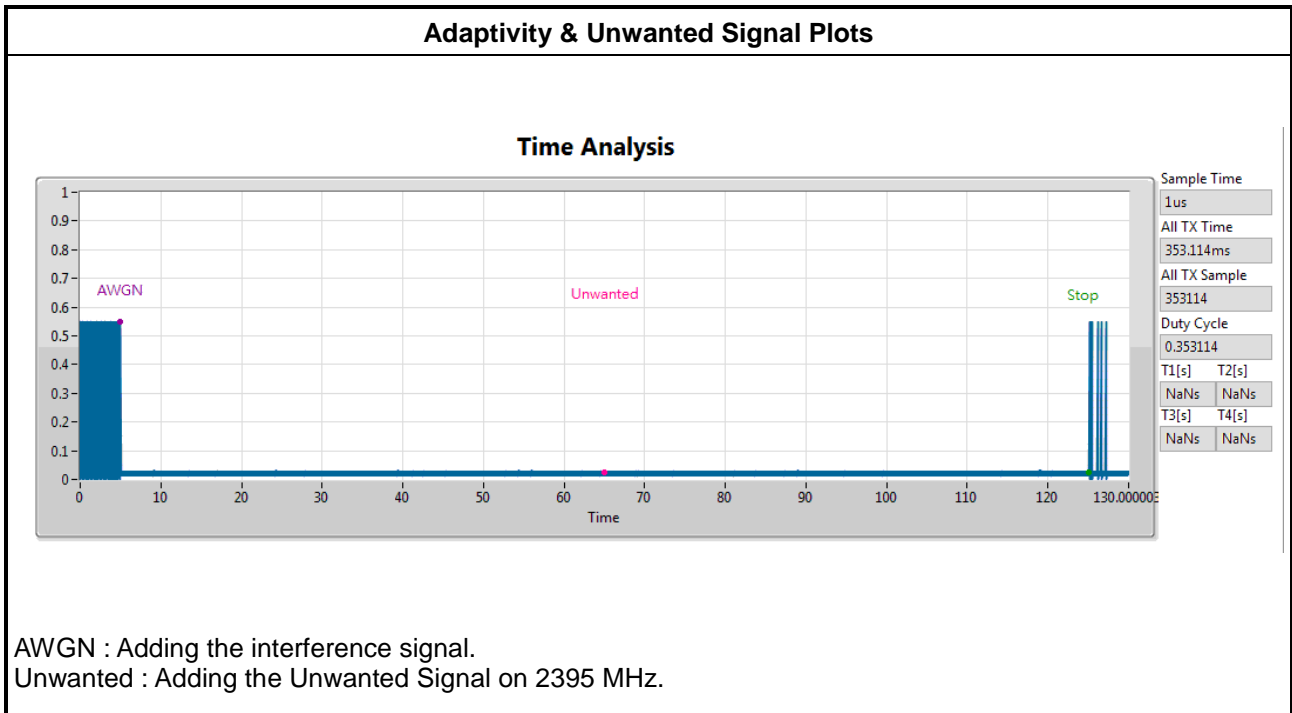

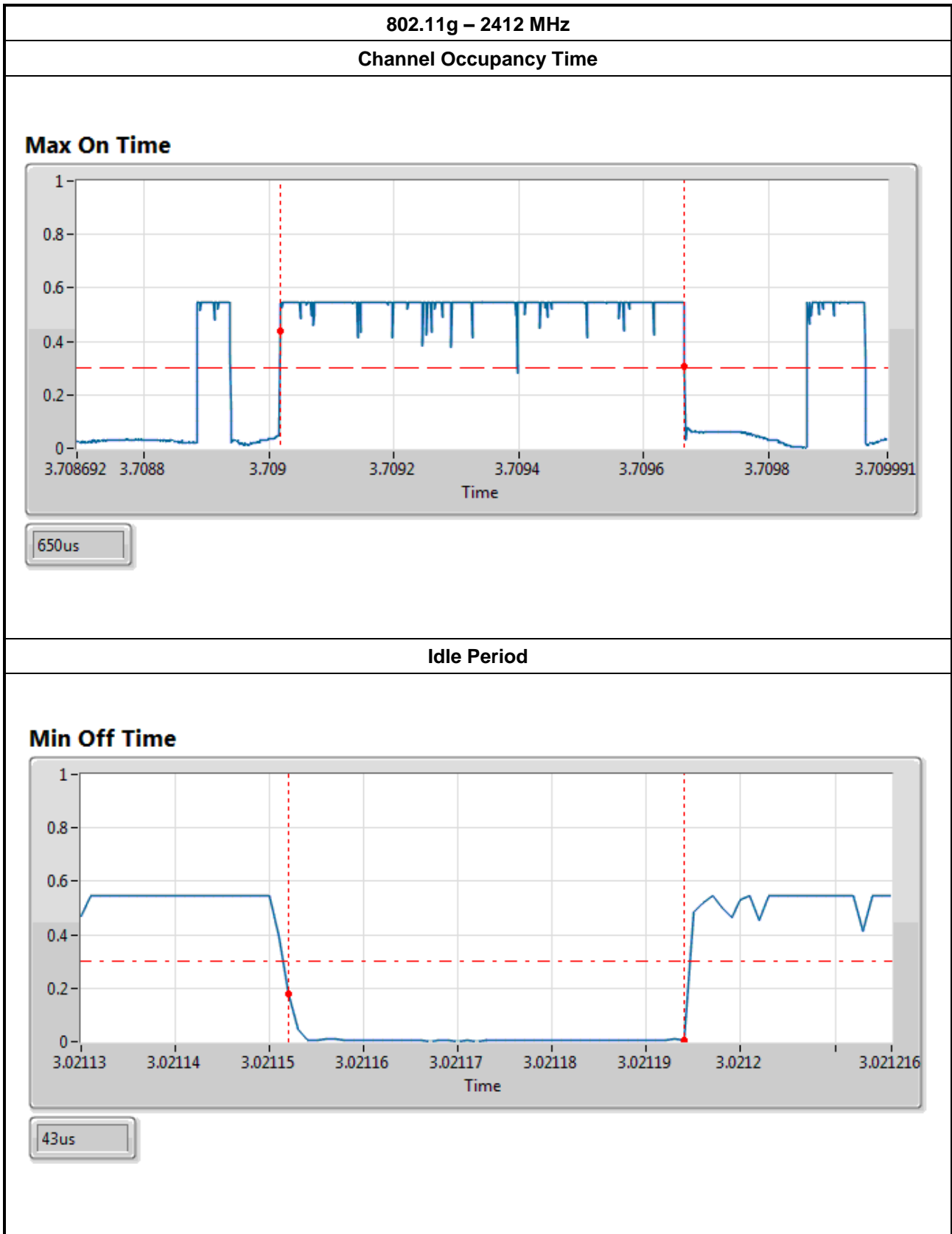

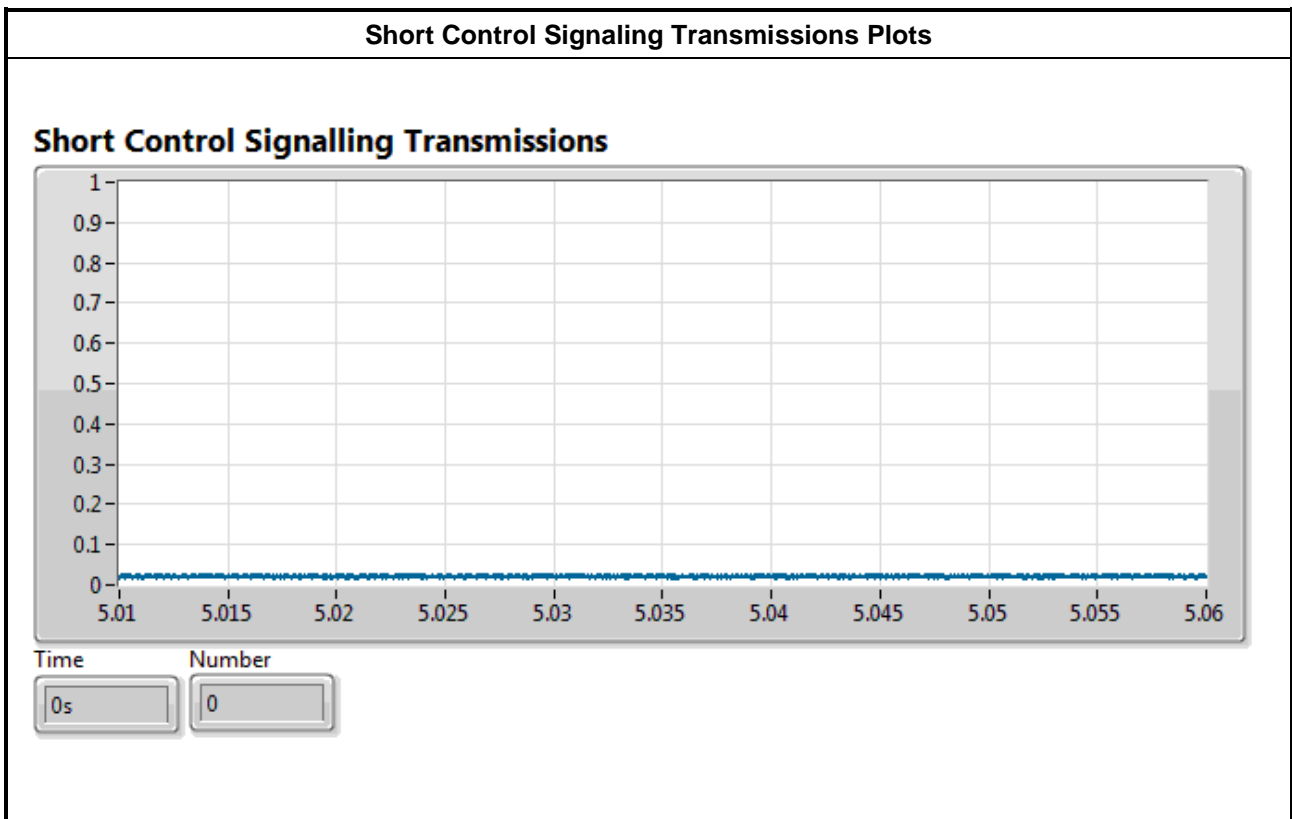
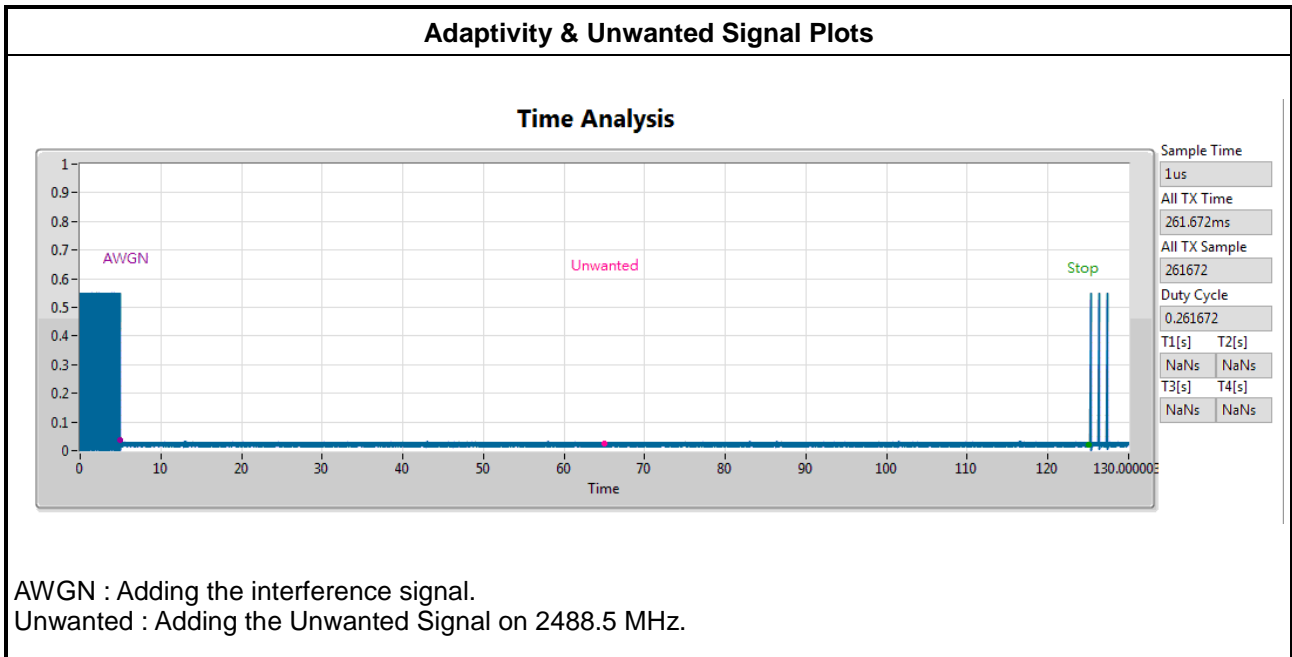



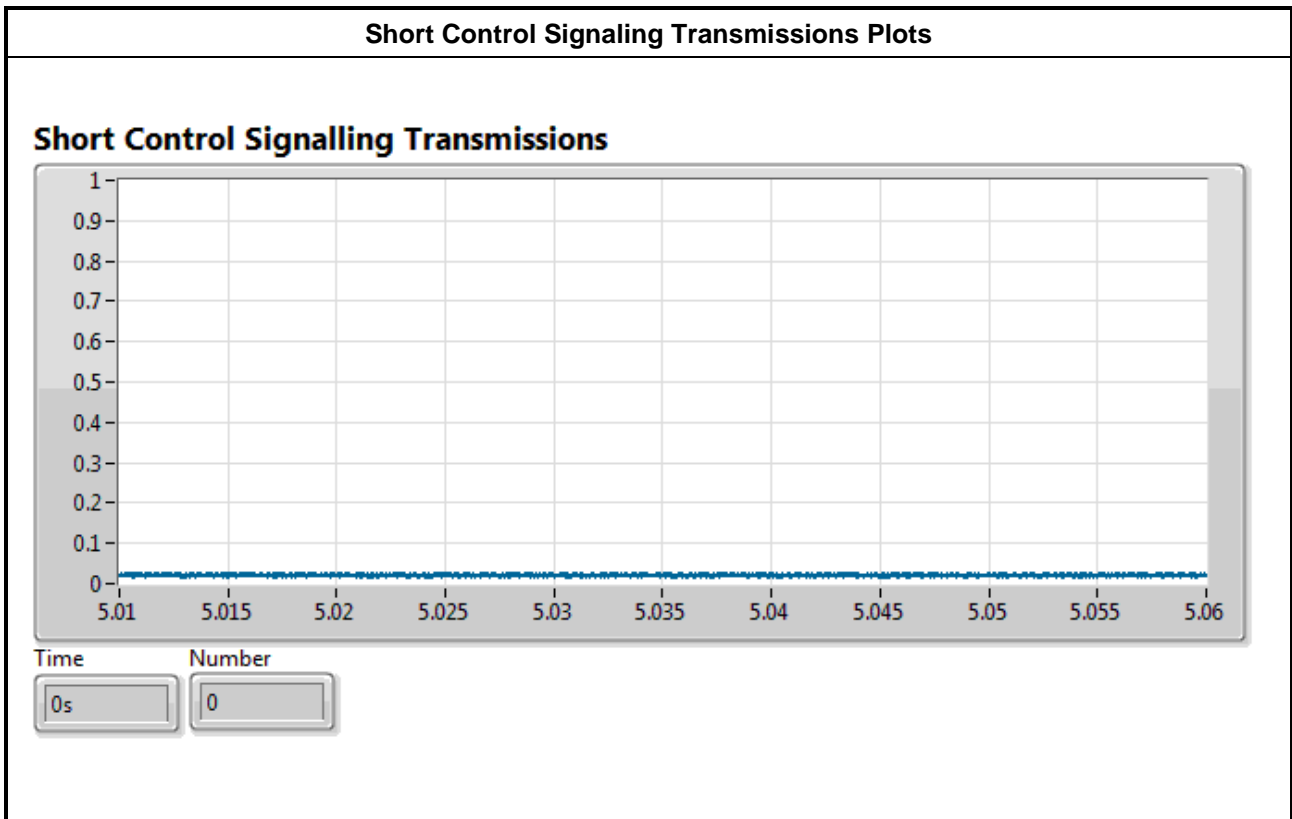
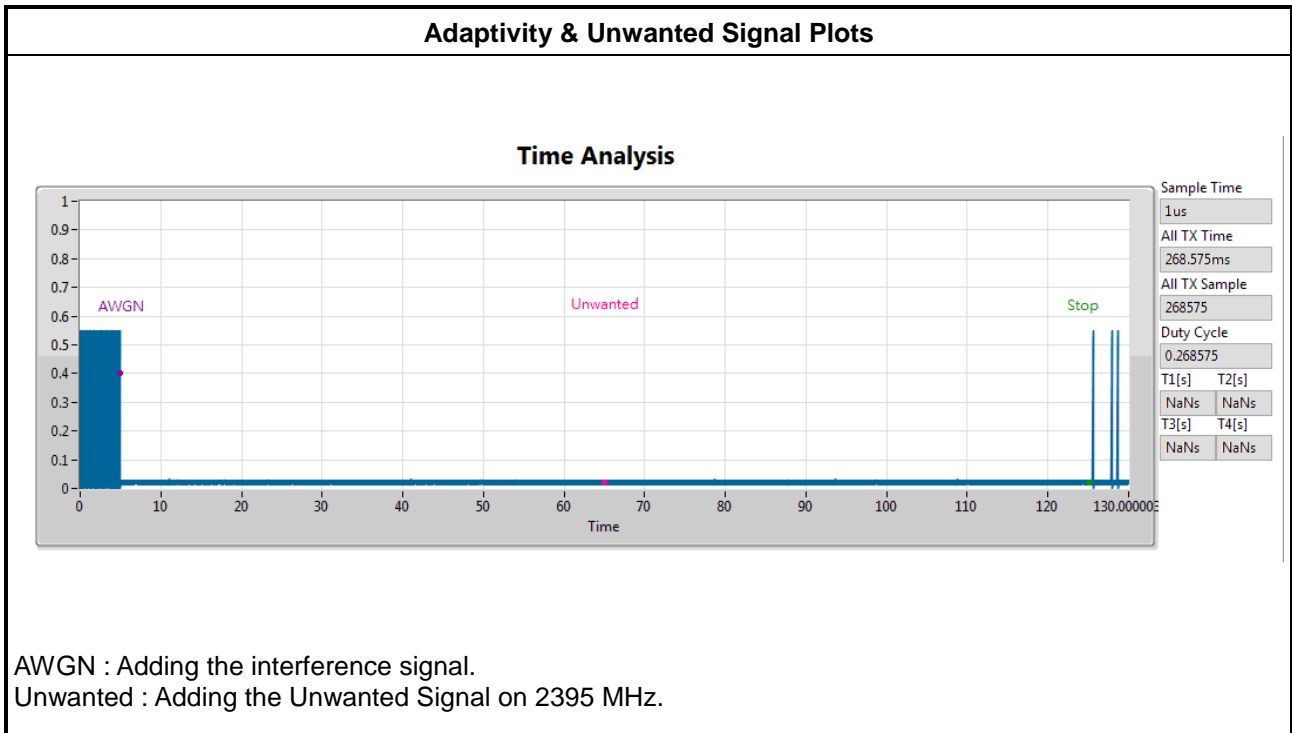

802.11n (HT20) – 2412 MHz

Channel Occupancy Time

Max On Time

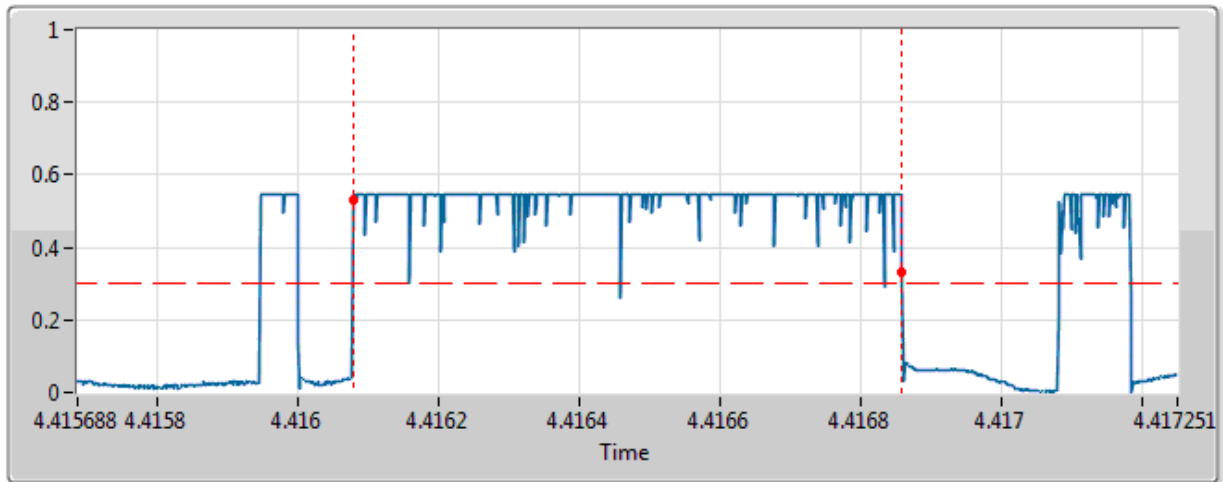

782us

Idle Period

Min Off Time

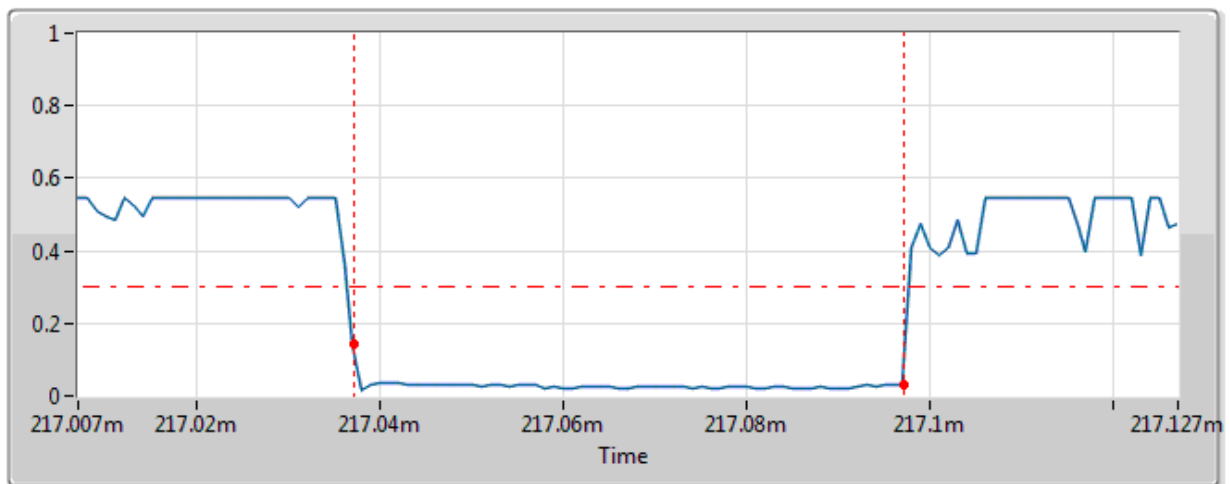

61us

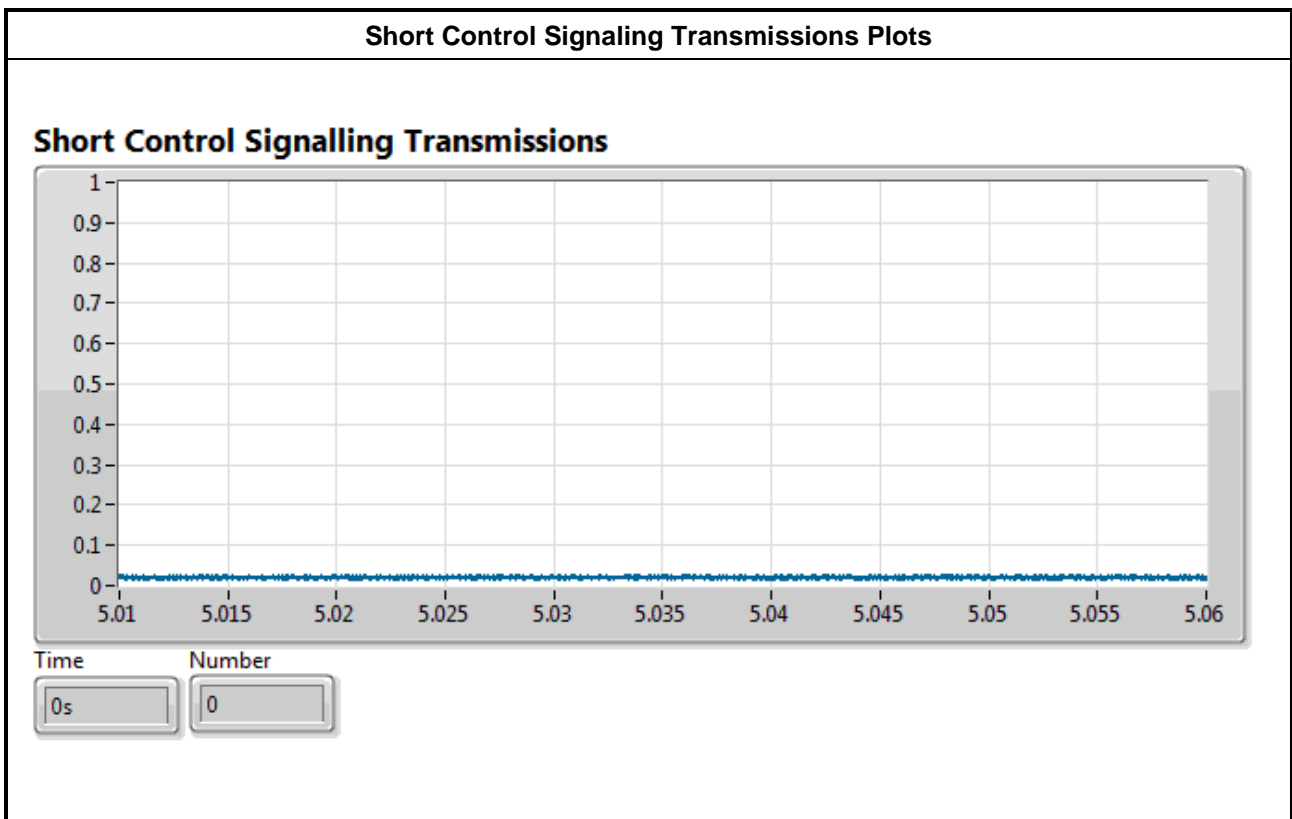
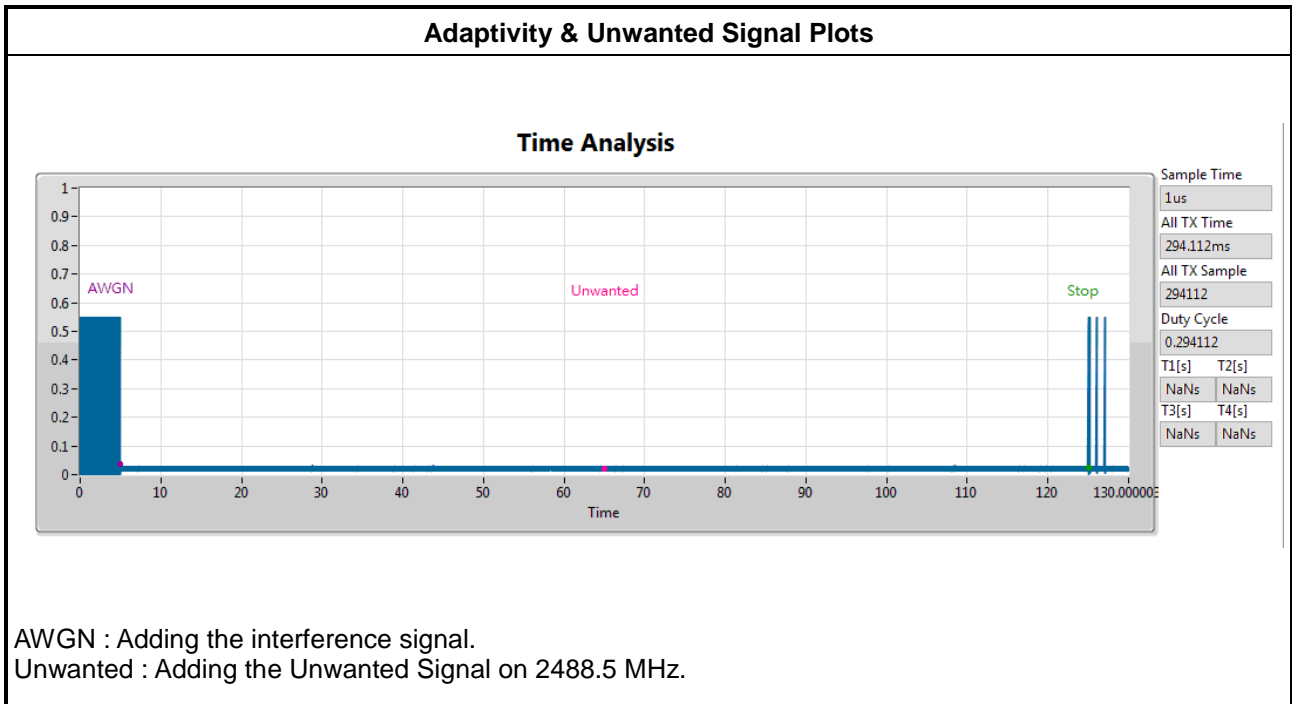

802.11n (HT20) – 2472 MHz

Channel Occupancy Time

Max On Time

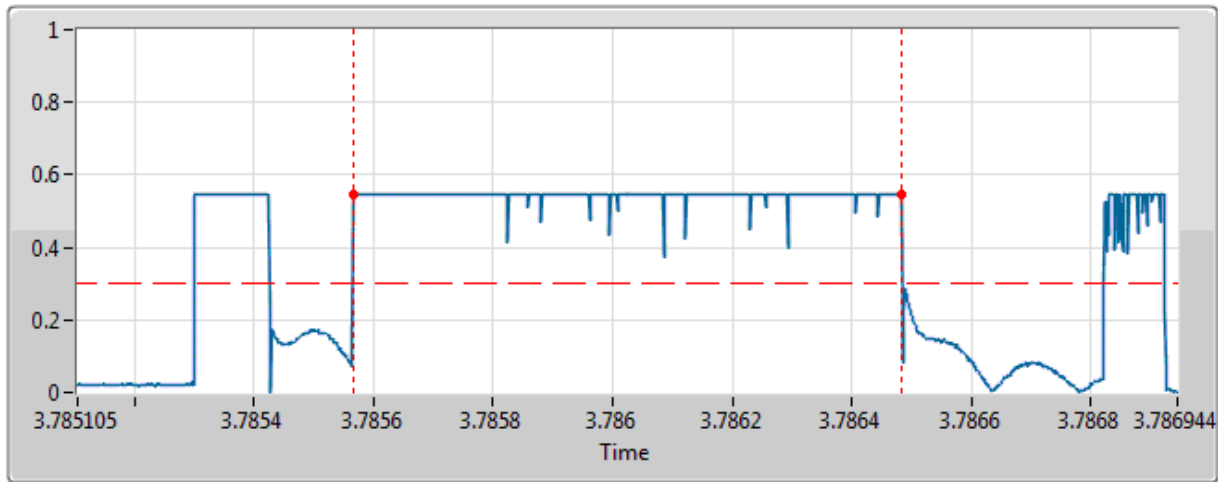

920us

Idle Period

Min Off Time

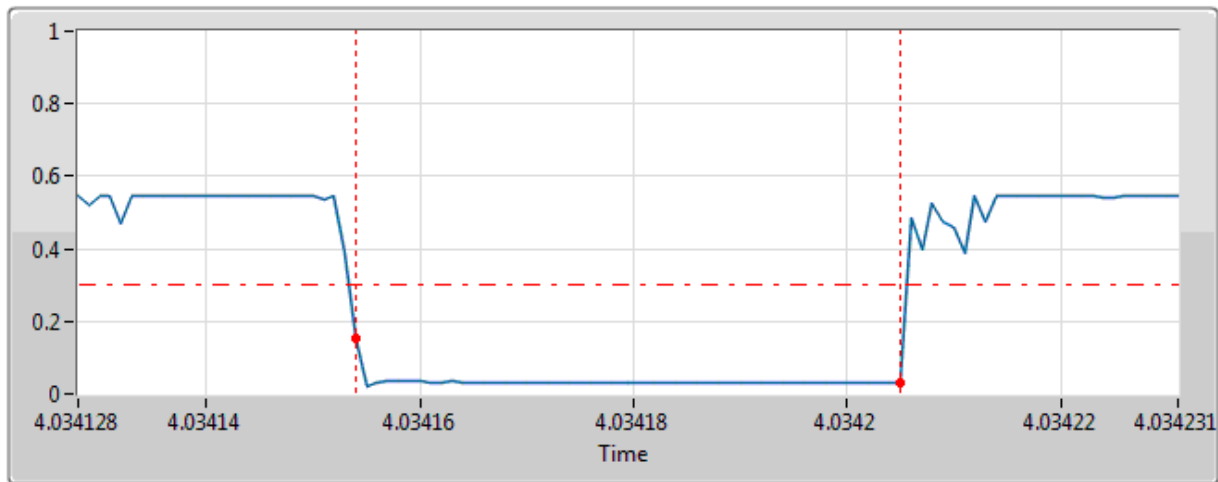

52us

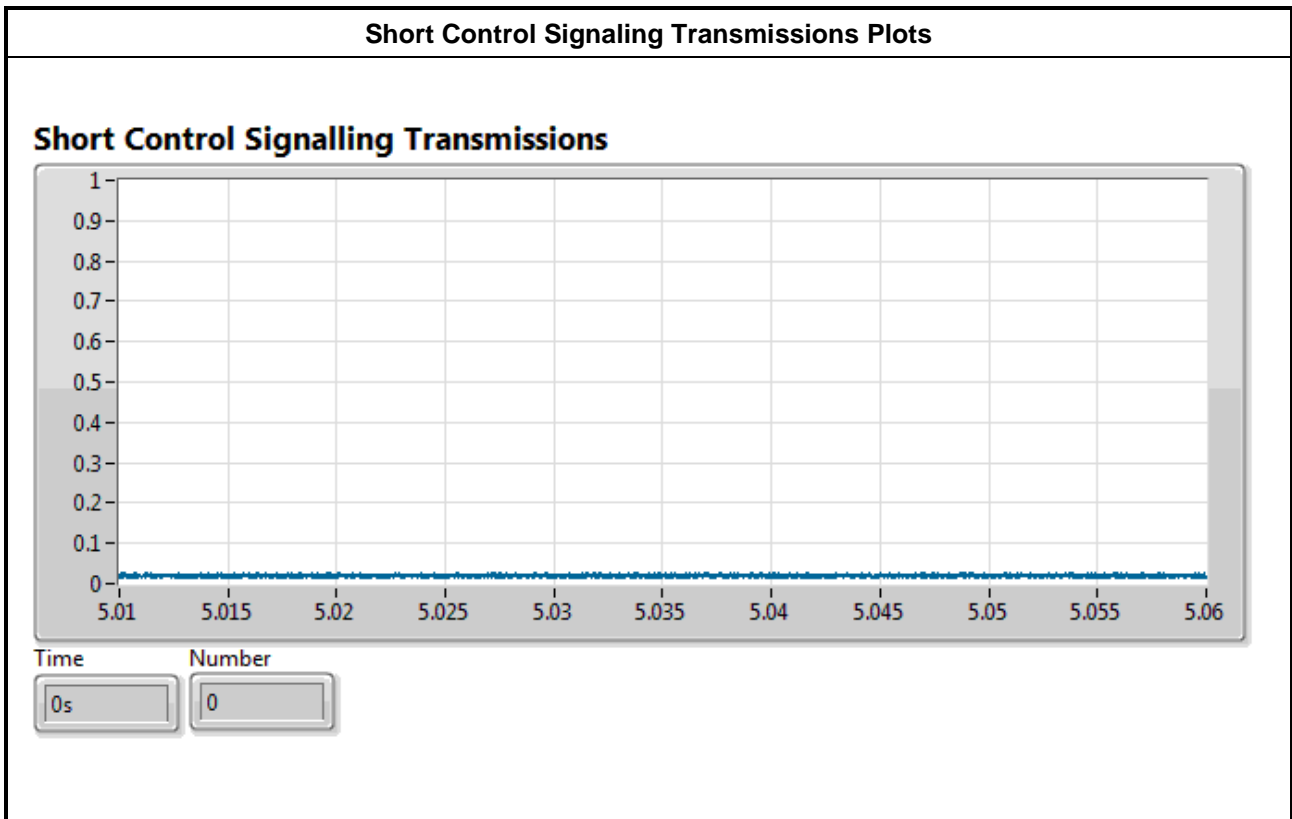
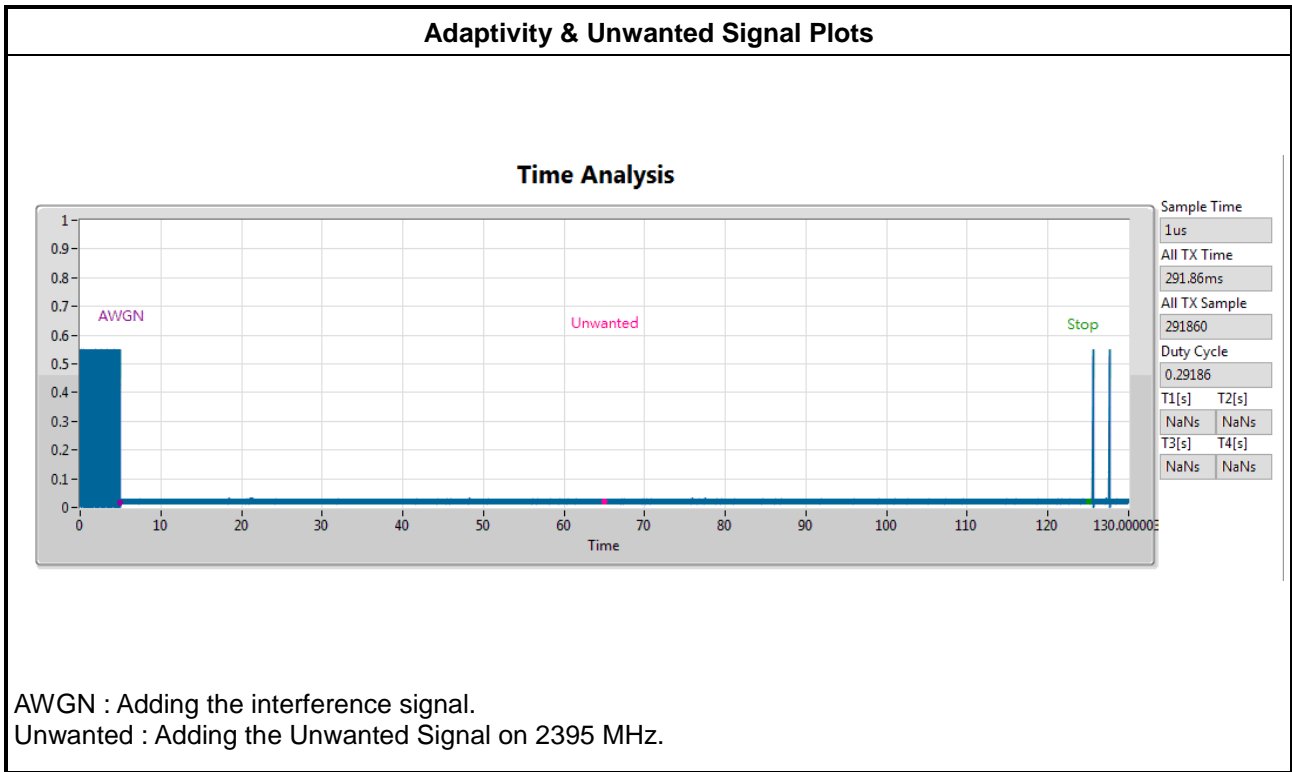

802.11n (HT40) – 2422 MHz

Channel Occupancy Time

Max On Time

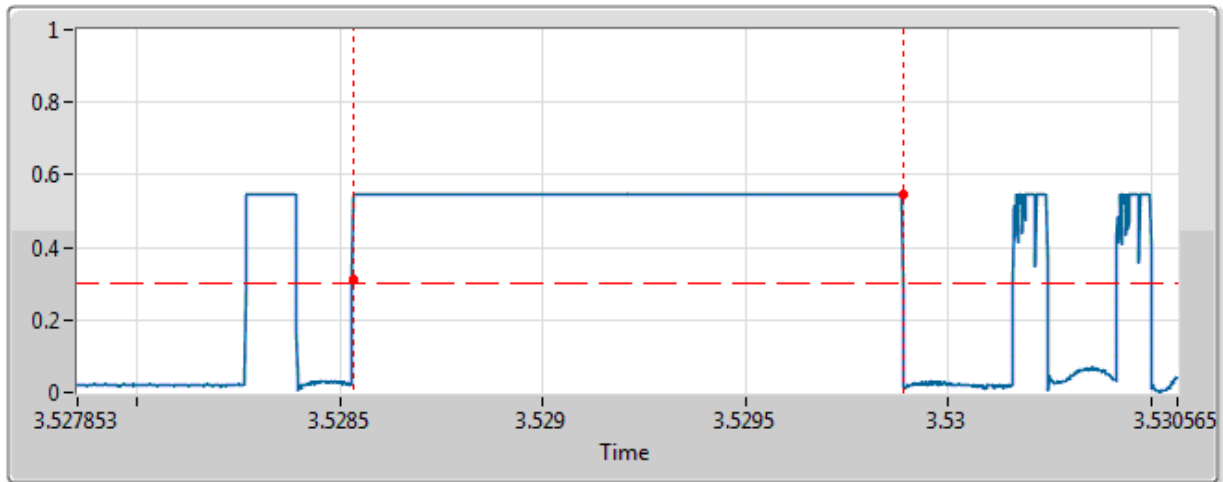

1.357ms

Idle Period

Min Off Time

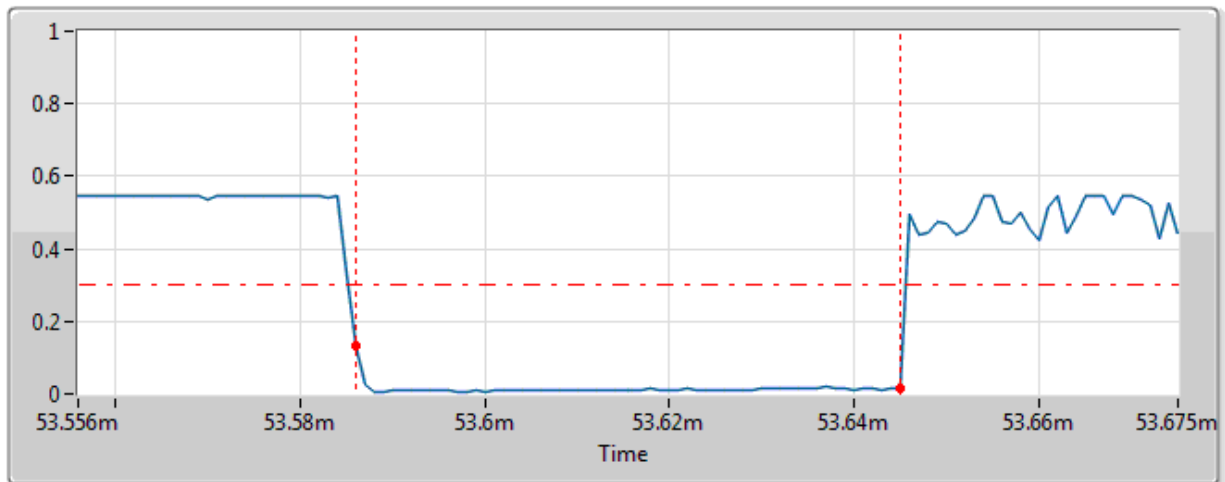

60us

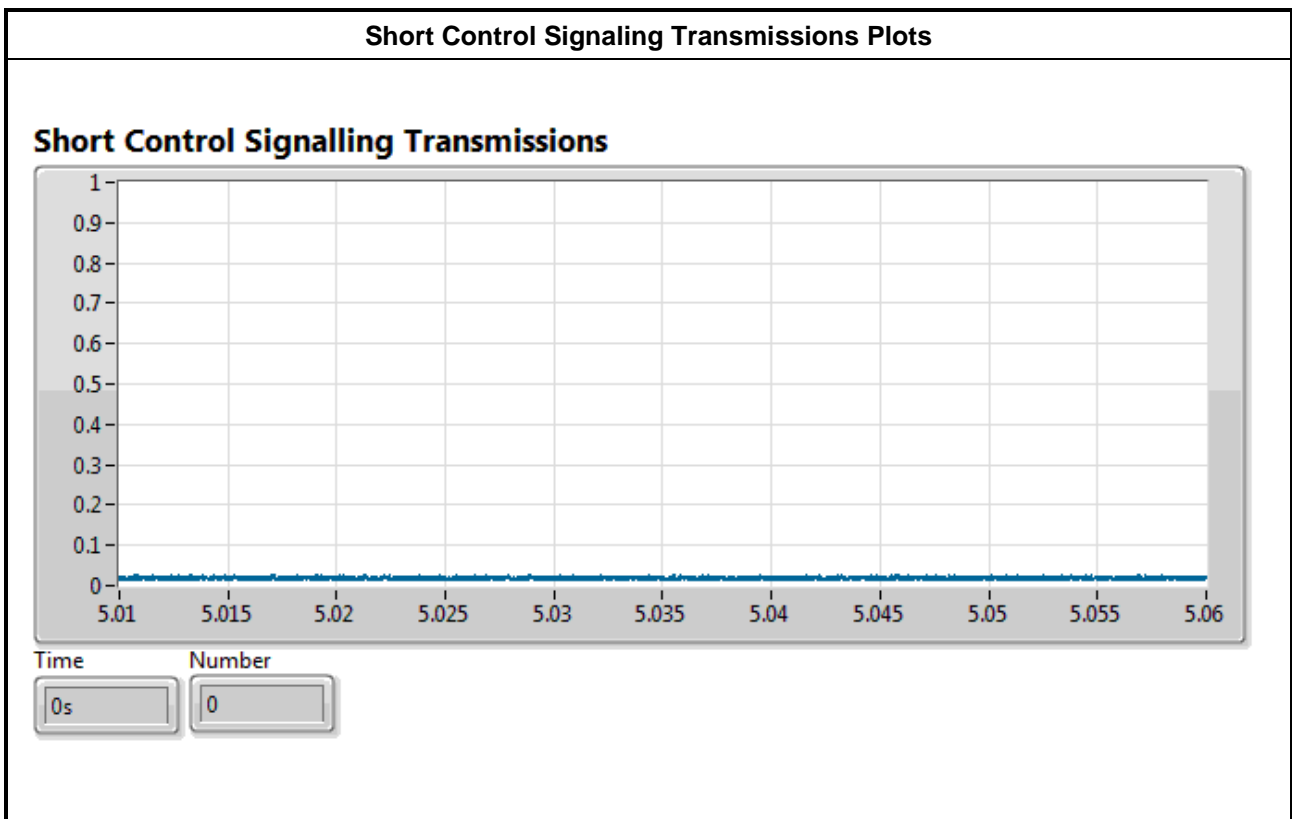
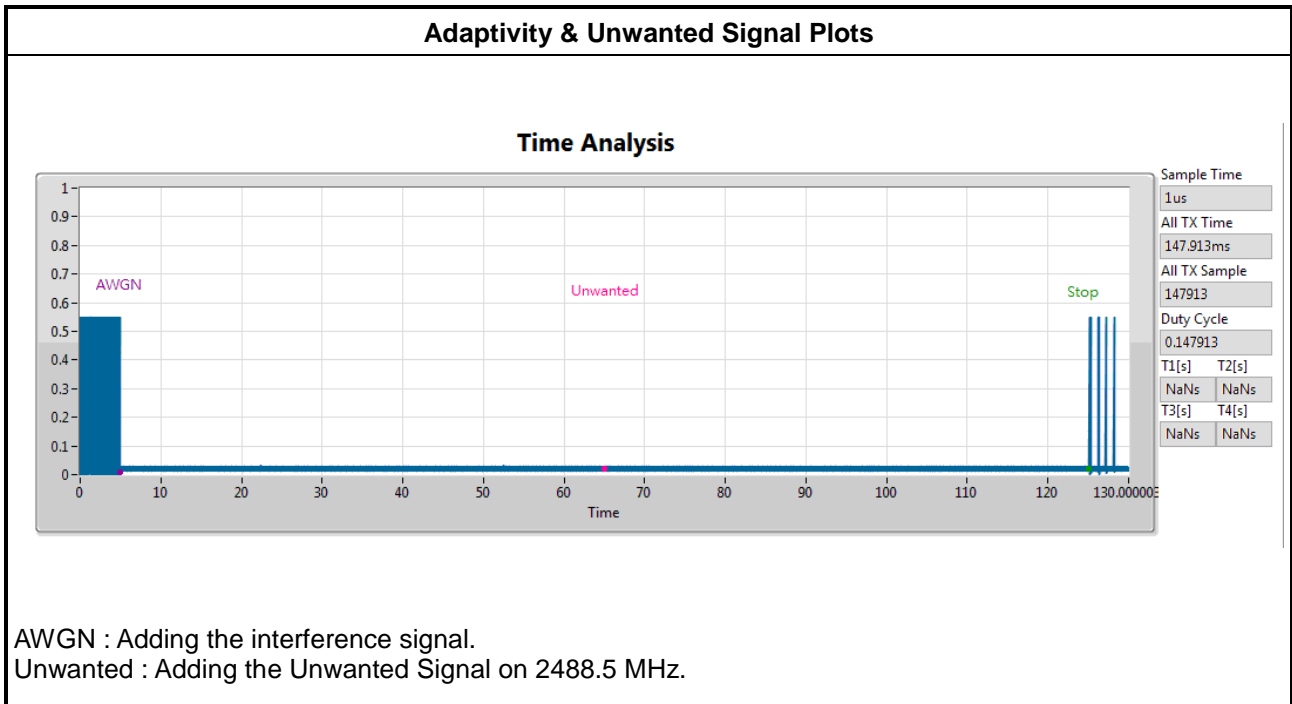

802.11n (HT40) – 2462 MHz

Channel Occupancy Time

Max On Time

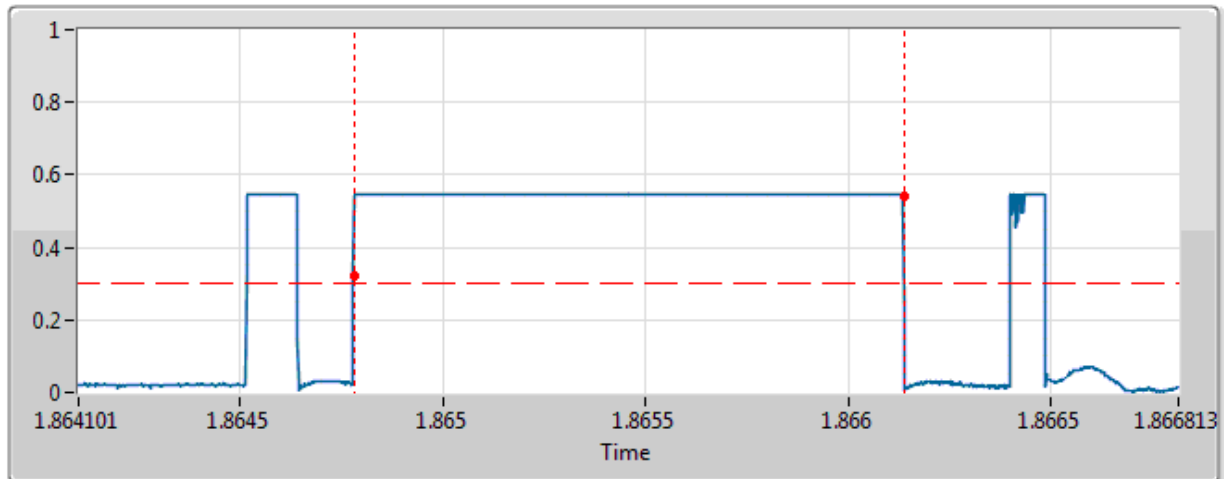

1.357ms

Idle Period

Min Off Time

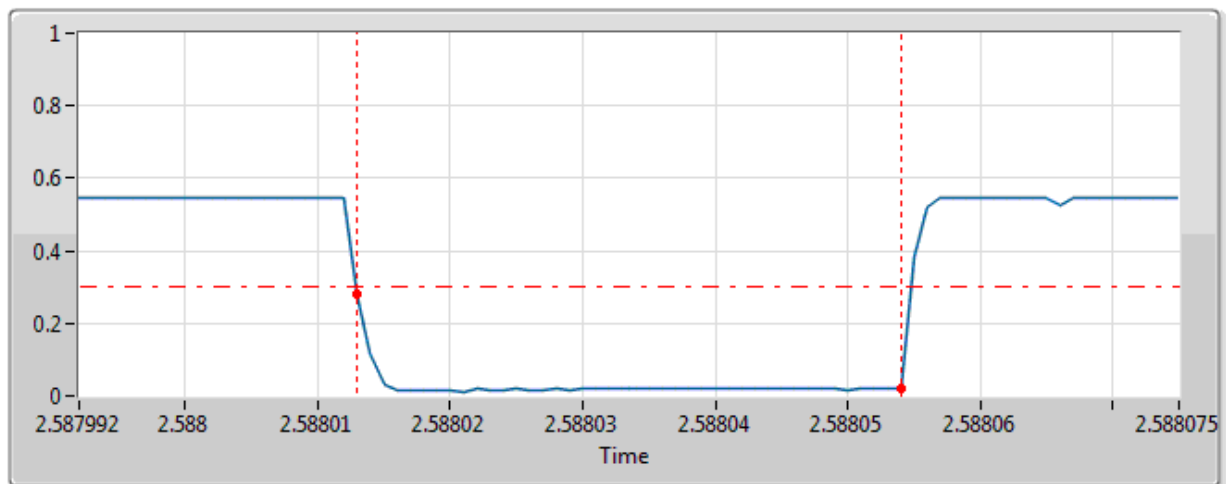

42us

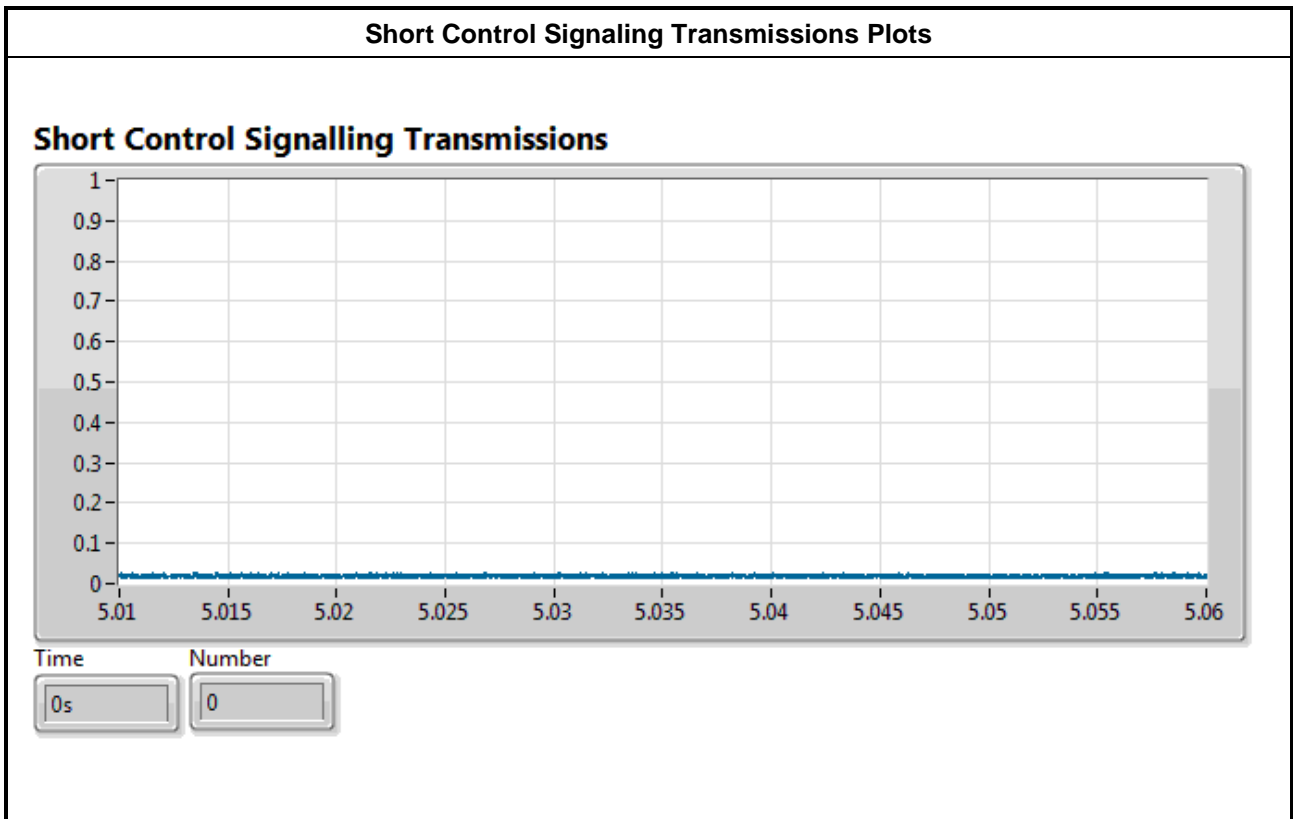
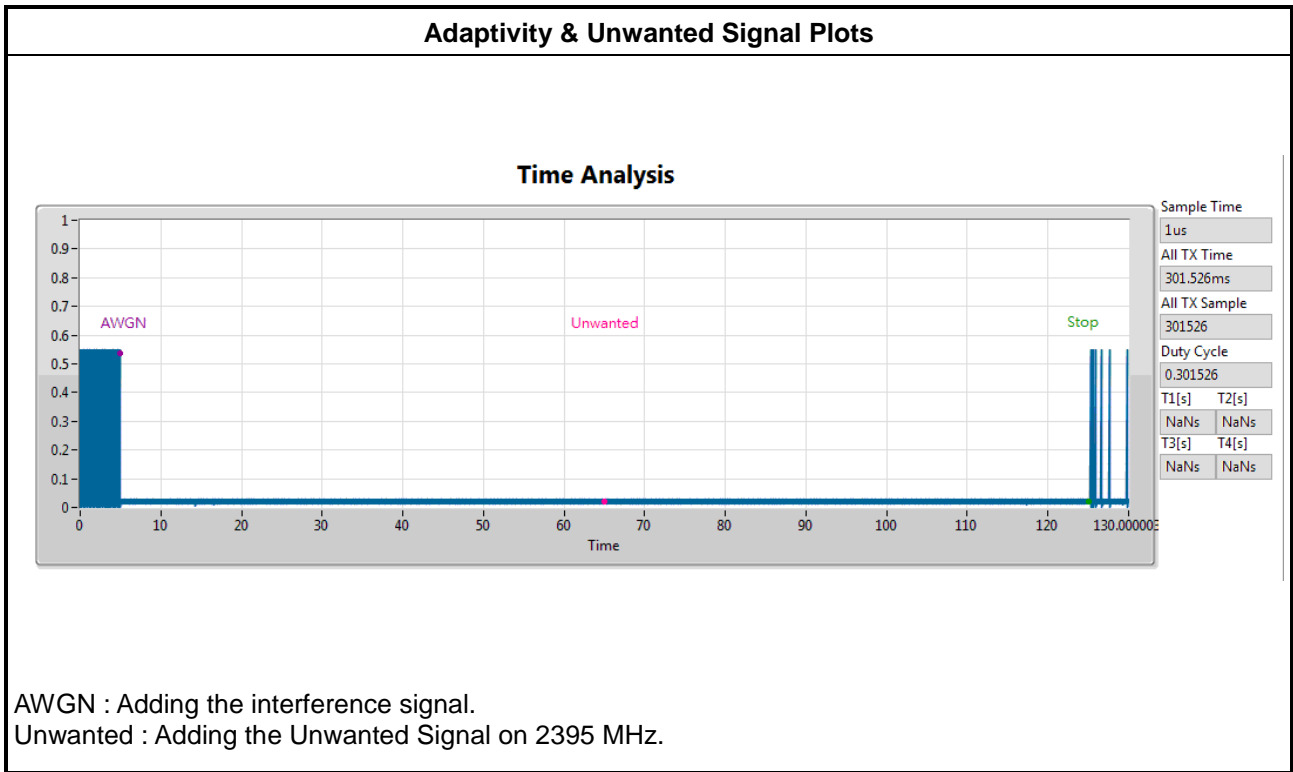

Receiver Blocking Result						
<b>P<sub>min</sub>(dBm)</b>	-96					
Modulation Mode	Operation Frequency (MHz)	Wanted Signal Mean Power from Companion Device (dBm)	Receiver Blocking Power (dBm)	Blocking Signal Frequency (MHz)	Type of Blocking Signal	Test Result
802.11b	2412	-65.6	-31.6	2380	CW	Pass
	2412	-71.6	-31.6	2300	CW	Pass
	2412	-71.6	-31.6	2330	CW	Pass
	2412	-71.6	-31.6	2360	CW	Pass
<b>Limit</b>	PER(Packet Error Rate) ≤ 10%					
<b>Result</b>	<b>Complied</b>					

Receiver Blocking Result						
<b>P<sub>min</sub>(dBm)</b>	-96					
Modulation Mode	Operation Frequency (MHz)	Wanted Signal Mean Power from Companion Device (dBm)	Receiver Blocking Power (dBm)	Blocking Signal Frequency (MHz)	Type of Blocking Signal	Test Result
802.11b	2472	-65.6	-31.6	2504	CW	Pass
	2472	-71.6	-31.6	2524	CW	Pass
	2472	-71.6	-31.6	2584	CW	Pass
	2472	-71.6	-31.6	2674	CW	Pass
<b>Limit</b>	PER(Packet Error Rate) ≤ 10%					
<b>Result</b>	<b>Complied</b>					

Receiver Blocking Result						
<b>P<sub>min</sub>(dBm)</b>	-91					
Modulation Mode	Operation Frequency (MHz)	Wanted Signal Mean Power from Companion Device (dBm)	Receiver Blocking Power (dBm)	Blocking Signal Frequency (MHz)	Type of Blocking Signal	Test Result
802.11g	2412	-65.6	-31.6	2380	CW	Pass
	2412	-71.6	-31.6	2300	CW	Pass
	2412	-71.6	-31.6	2330	CW	Pass
	2412	-71.6	-31.6	2360	CW	Pass
<b>Limit</b>	PER(Packet Error Rate) ≤ 10%					
<b>Result</b>	<b>Complied</b>					

Receiver Blocking Result						
<b>P<sub>min</sub>(dBm)</b>	-91					
Modulation Mode	Operation Frequency (MHz)	Wanted Signal Mean Power from Companion Device (dBm)	Receiver Blocking Power (dBm)	Blocking Signal Frequency (MHz)	Type of Blocking Signal	Test Result
802.11g	2472	-65.6	-31.6	2504	CW	Pass
	2472	-71.6	-31.6	2524	CW	Pass
	2472	-71.6	-31.6	2584	CW	Pass
	2472	-71.6	-31.6	2674	CW	Pass
<b>Limit</b>	PER(Packet Error Rate) ≤ 10%					
<b>Result</b>	<b>Complied</b>					

## 1. Photographs of Radiated Emissions Test Configuration

Front view



Rear view

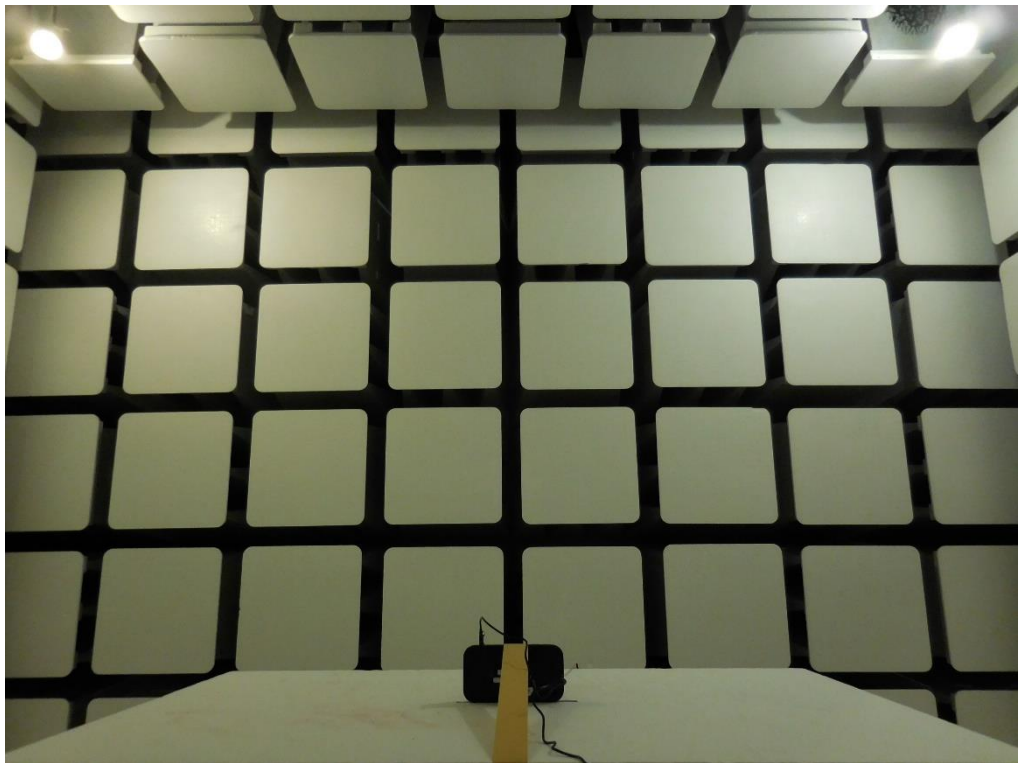

Bilog Antenna

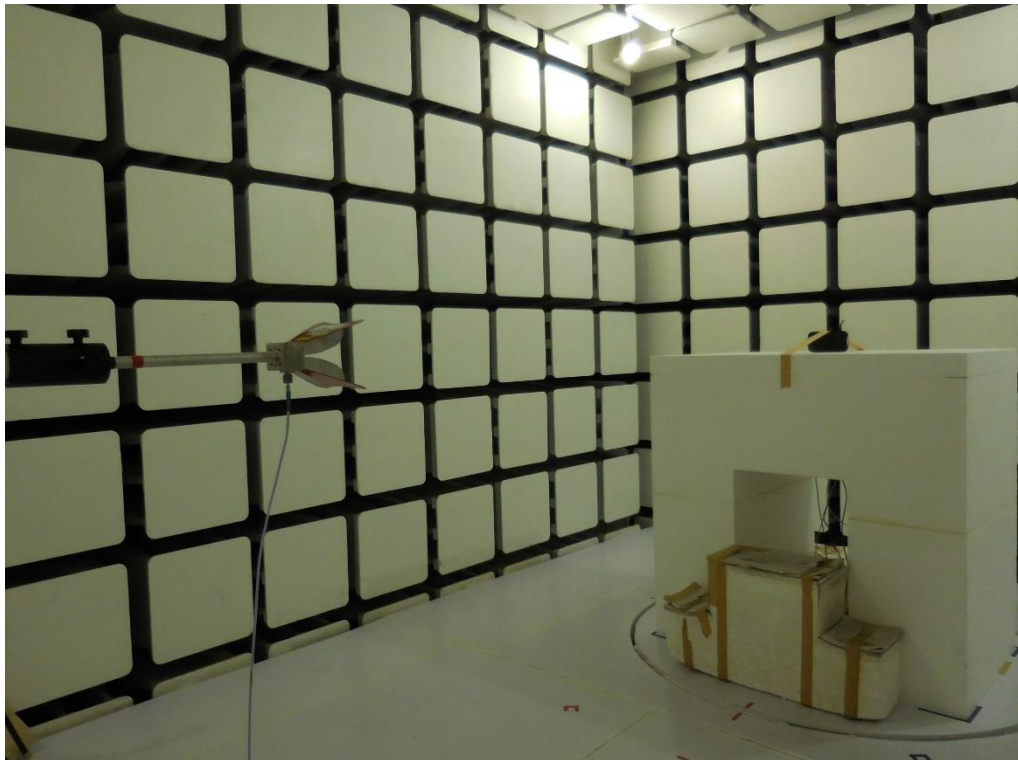

Horn Antenna

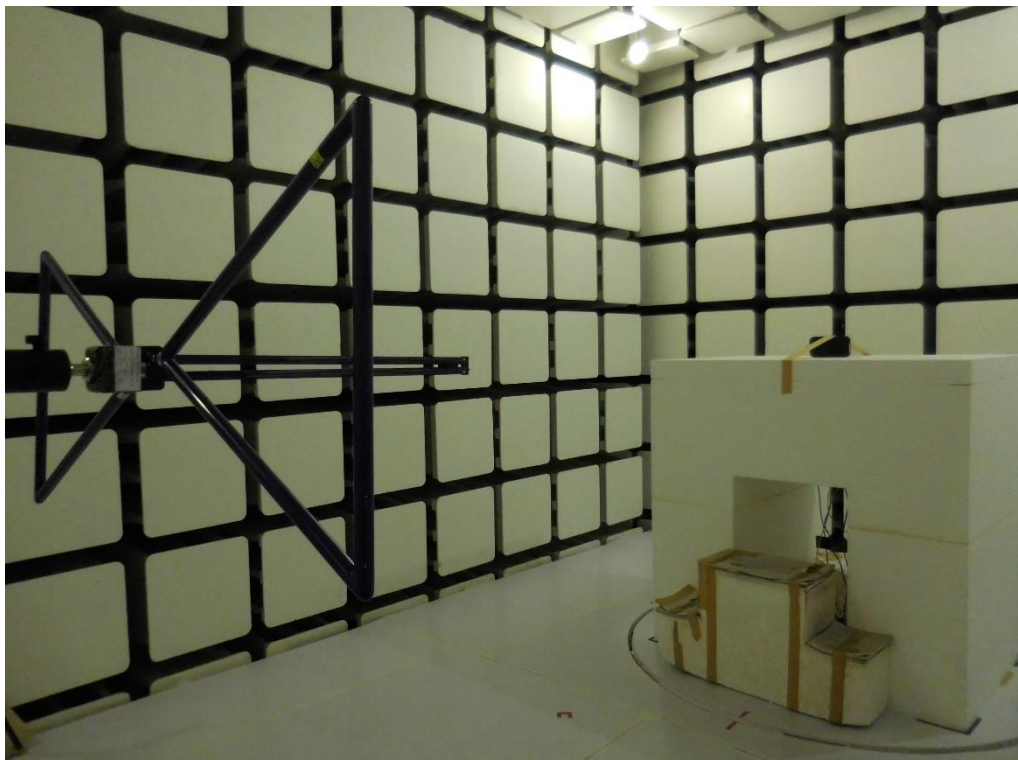

EUT take a close-up

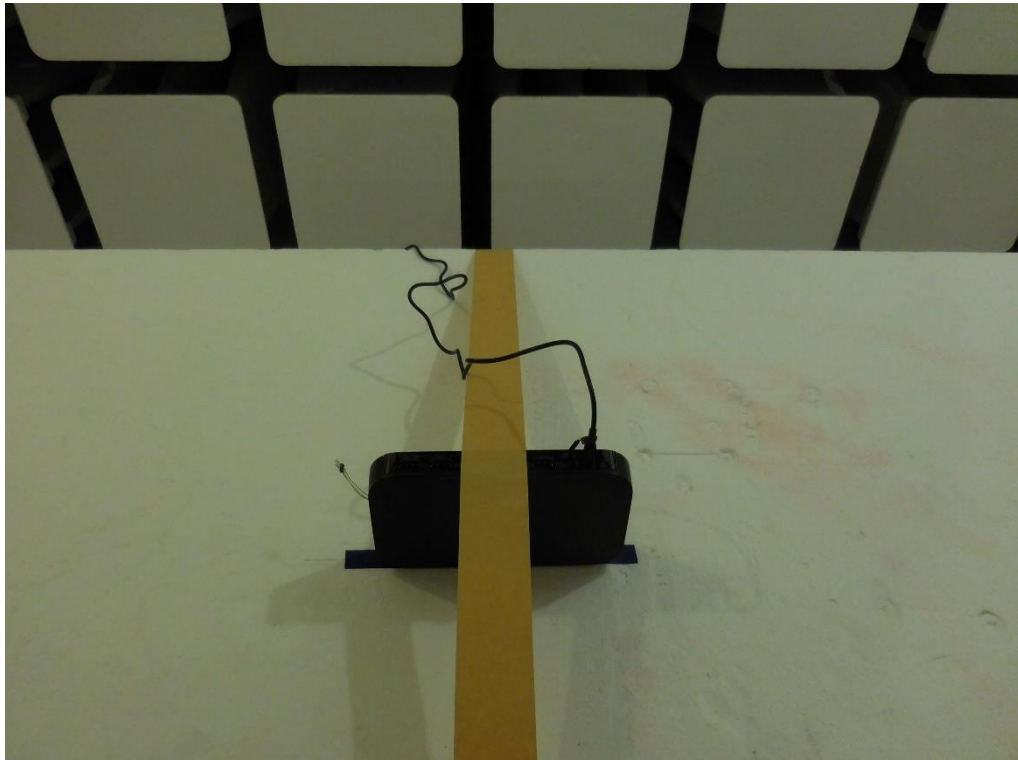

EUT take a close-up

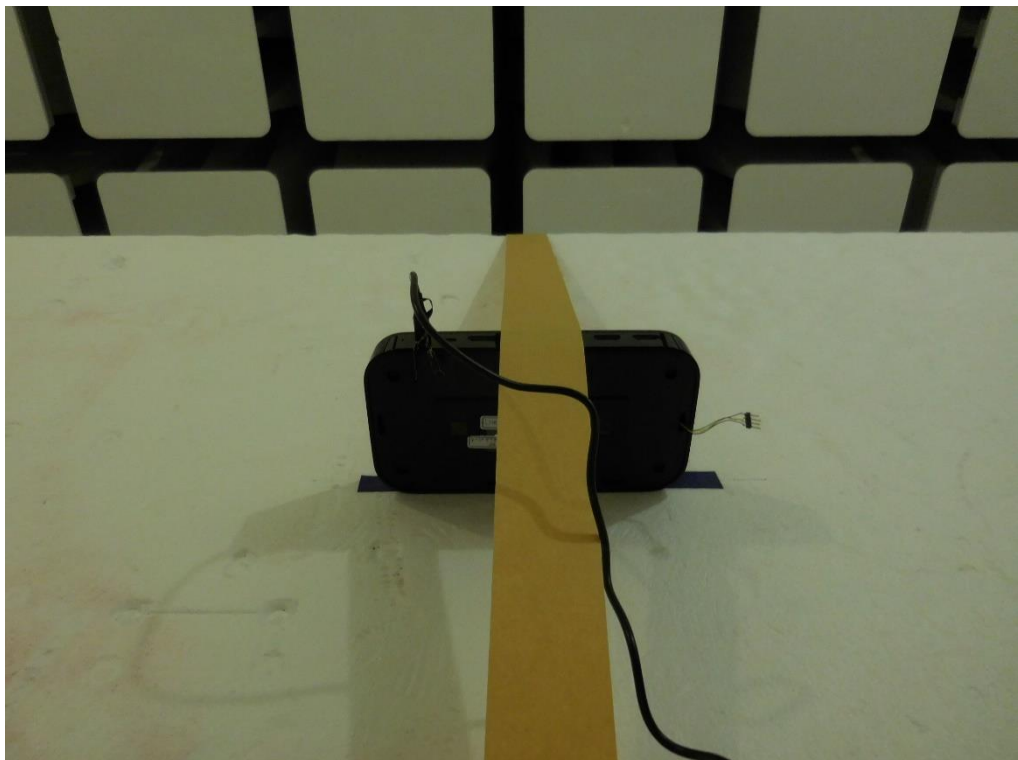

## 2. Photographs of Adaptivity Test Configuration

Front view

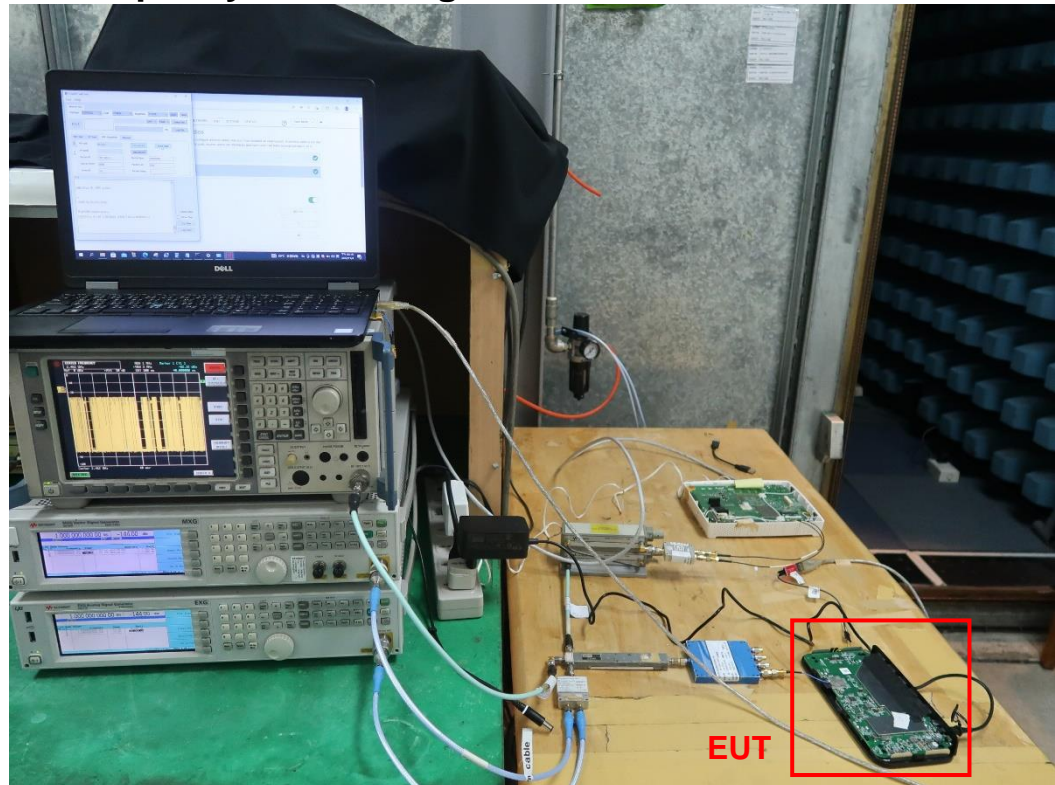

### 3. Photographs of Receiver Blocking Test Configuration

Front view



EUT take a close-up

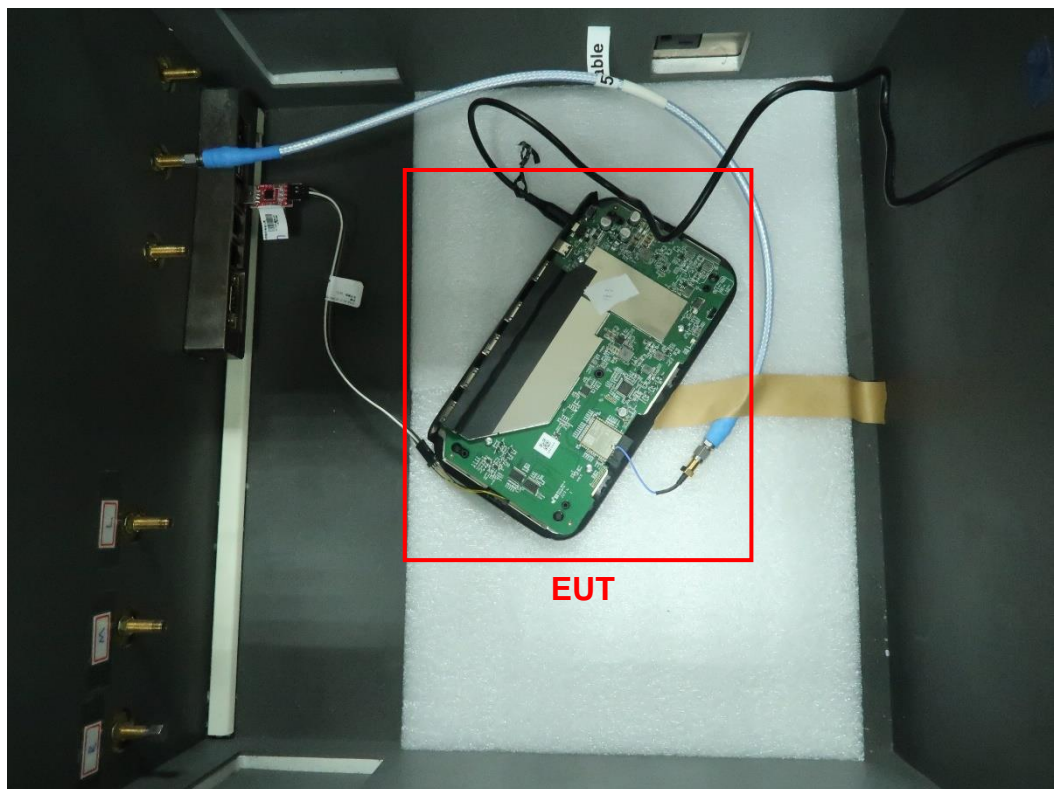

—————THE END—————

# Radio Test Report

**Equipment** : HDMI Sync Box  
**Brand Name** : PHILIPS  
**Model Name** : 9290034996  
**Applicant** : Signify (China) Investment Co., Ltd.  
Building 9, Lane 888, Tianlin Road,  
Minhang District, Shanghai 200233 China  
**Manufacturer** : Signify (China) Investment Co., Ltd.  
Building 9, Lane 888, Tianlin Road,  
Minhang District, Shanghai 200233 China  
**Standard** : EN 300 328 V2.2.2 (2019-07)

The product was received on Sep. 23, 2022, and testing was started from Oct. 17, 2022 and completed on Nov. 04, 2022. We, SPORTON INTERNATIONAL INC. Hsinhua Laboratory, would like to declare that the tested sample has been evaluated in accordance with the procedures given in EN 300 328 V2.2.2 (2019-07) and shown compliance with the applicable technical standards.

The test results in this variant report apply exclusively to the tested model / sample. Without written approval of SPORTON INTERNATIONAL INC. Hsinhua Laboratory, the test report shall not be reproduced except in full.



---

Approved by: Jackson Tsai

**SPORTON INTERNATIONAL INC. Hsinhua Laboratory**  
No.52, Huaya 1st Rd., Guishan Dist., Taoyuan City 333411, Taiwan (R.O.C.)



## Table of Contents

**HISTORY OF THIS TEST REPORT .....4**

**SUMMARY OF TEST RESULT .....5**

**1 GENERAL DESCRIPTION .....6**

1.1 Information.....6

1.2 Testing Applied Standards .....9

1.3 Testing Location Information .....9

1.4 Measurement Uncertainty .....9

**2 TEST CONFIGURATION OF EUT.....10**

2.1 Test Condition .....10

2.2 Test Channel Mode .....10

2.3 The Worst Case Measurement Configuration.....11

2.4 Accessories .....12

2.5 Support Equipment.....12

2.6 Test Setup Diagram .....13

**3 TRANSMITTER TEST RESULT .....14**

3.1 RF Output Power .....14

3.2 Power Spectral Density .....16

3.3 Occupied Channel Bandwidth .....19

3.4 Transmitter Unwanted Emissions in the Out-of-band Domain .....21

3.5 Transmitter Unwanted Emissions in the Spurious Domain .....24

**4 RECEIVER TEST RESULT .....28**

4.1 Receiver Spurious Emissions.....28

**5 RECEIVER BLOCKING TEST RESULT .....32**

5.1 Receiver Blocking.....32

**6 TEST EQUIPMENT AND CALIBRATION DATA .....36**

**APPENDIX A. TEST RESULTS OF RF OUTPUT POWER**

**APPENDIX B. TEST RESULTS OF POWER SPECTRAL DENSITY**

**APPENDIX C. TEST RESULTS OF OCCUPIED CHANNEL BANDWIDTH**

**APPENDIX D. TEST RESULTS OF TRANSMITTER UNWANTED EMISSIONS IN THE OOB DOMAIN**

**APPENDIX E. TEST RESULTS OF TRANSMITTER UNWANTED EMISSIONS IN THE SPURIOUS DOMAIN**

**APPENDIX F. TEST RESULTS OF RECEIVER SPURIOUS EMISSIONS**

**APPENDIX G. TEST RESULTS OF RECEIVER BLOCKING**



**APPENDIX H. TEST PHOTOS**

**PHOTOGRAPHS OF EUT v01**





### Summary of Test Result

Report Clause	Ref Std. Clause	Test Items	Result (PASS/FAIL)	Remark
3.1	4.3.2.2	RF Output Power	PASS	-
3.2	4.3.2.3	Power Spectral Density	PASS	-
3.3	4.3.2.7	Occupied Channel Bandwidth	PASS	-
3.4	4.3.2.8	Transmitter unwanted emissions in the out-of-band domain	PASS	-
3.5	4.3.2.9	Transmitter unwanted emissions in the spurious domain	PASS	-
4.1	4.3.2.10	Receiver spurious emissions	PASS	-
5.1	4.3.2.11	Receiver Blocking	PASS	-
1.1.8	4.3.2.12	Geo-location capability	N/A	-

<b>Declaration of Conformity:</b>
The test results with all measurement uncertainty excluded are presented in accordance with the regulation limits or requirements declared by manufacturers.
<b>Comments and explanations:</b>
None

Reviewed by: Ryan Hsiao

Report Producer: Amber Chiu

# 1 General Description

## 1.1 Information

### 1.1.1 RF General Information

Frequency Range (MHz)	Bluetooth Mode	Ch. Frequency (MHz)	Channel Number
2400-2483.5	LE	2402-2480	0-39 [40]

Band	Mode	BWch (MHz)	Nant
2.4-2.4835GHz	BT-LE(125kbps)	1.0	1TX
2.4-2.4835GHz	BT-LE(500kbps)	1.0	1TX
2400-2483.5	BT-LE(1Mbps)	1.0	1TX
2400-2483.5	BT-LE(2Mbps)	2.0	1TX

**Note:**

- ◆ Bluetooth LE uses a GFSK (125kbps/500kbps/1Mbps/2Mbps) modulation.
- ◆ BWch is the nominal channel bandwidth.

### 1.1.2 Antenna Information

Ant.	Brand	Model Name	Antenna Type	Connector	Gain (dBi)
1	ESPRESSIF	ESP32-S3-WROOM-2	PIFA antenna	N/A	2.4

Note 1: The EUT has one antenna.

**For 2.4GHz function:**

For IEEE 802.11 b/g/n mode (1TX/1RX)

Ant. 1 could transmit/receive.

**For BT function:**

For IEEE 802.15.1 Bluetooth mode (1TX/1RX)

Ant. 1 could transmit/receive.



1.1.3 EUT Information

Operational Condition	
EUT Power Type	From AC Adapter
Software / Firmware Version for Receiver Blocking	ESP32-S3_RF_Test_Bin_V108_bfedf05_20220301.bin
Type of EUT	
<input checked="" type="checkbox"/>	Stand-alone
<input type="checkbox"/>	Combined (EUT where the radio part is fully integrated within another device)
	Combined Equipment - Brand Name / Model No.: ...
<input type="checkbox"/>	Plug-in radio (EUT intended for a variety of host systems)
	Host System - Brand Name / Model No.: ...
<input type="checkbox"/>	Other:

1.1.4 Duty Cycle

Mode	DC	DCF (dB)
BT-LE(1Mbps)	0.84	0.757
BT-LE(125kbps)	0.924	0.343
BT-LE(500kbps)	0.896	0.477
BT-LE(2Mbps)	0.558	2.534

1.1.5 Table for Multiple Listing

Table for Explanation of 2nd Source.

Object/part or Description (location)	Location	Main source (SKU 1)	2nd source (SKU 2)
level shift	U37	Brand: UTC Model: ULSF0204G-P14-R	Brand: TI Model: LSF0204PWR
Power IC	U2	Brand: GMT Model: G5335QT1U	Brand: ANPEC Model: APW8713EQBI-TRG
IO IC	U27,U56	Brand: NOVOSENSE Model: NCA9555	Brand: NXP Model: PCA9555APW
Fuse	F1	Brand: Littelfuse Model: 2016L260/24	Brand: PTTC Model: 2016P260TF/24

From the above SKU, all of SKUs were verified and Main source (SKU 1) was selected as representative SKU for the test and its data was recorded in this report.

1.1.6 Table for Existing Change

This product is an extension of original one reported under Sporton project number: ER271604AL

Below is the table for the change of the product with respect to the original one.

Modifications	Performance Checking
<ol style="list-style-type: none"> <li>Change thermal absorber</li> <li>Add 5pcs gasket</li> </ol>	<ol style="list-style-type: none"> <li>The worst case of Radiated Unwanted Emissions was evaluated, and the test result of original report was found to be the worst case scenario.</li> <li>Photographs of EUT.</li> </ol>



1.1.7 Adaptive Equipment

Adaptive Equipment	
<input checked="" type="checkbox"/>	non-Adaptive Equipment
<input type="checkbox"/>	Adaptive Equipment without the possibility to switch to a non-adaptive mode:
<input type="checkbox"/>	Maximum declared RF Output power of less than 10 dBm e.i.r.p.
<input type="checkbox"/>	The equipment has implemented an LBT based DAA mechanism:
<input type="checkbox"/>	The equipment is Frame Based equipment
<input type="checkbox"/>	The equipment is Load Based equipment
<input type="checkbox"/>	The equipment can switch dynamically between Frame Based and Load Based equipment
<input type="checkbox"/>	The equipment has implemented an non-LBT based DAA mechanism
<input type="checkbox"/>	The equipment can operate in more than one adaptive mode
<input type="checkbox"/>	Adaptive Equipment which can also operate in a non-adaptive mode

1.1.8 Geo-location capability supported by the equipment

Geo-location capability supported by the equipment	
<input type="checkbox"/>	Yes
<input type="checkbox"/>	The geographical location determined by the equipment as defined in EN 300 328, clause 4.3.2.12.3 is not accessible to the user.
<input checked="" type="checkbox"/>	No

## 1.2 Testing Applied Standards

According to the specifications of the manufacturer, the EUT must comply with the requirements of the following standards:

- ♦ EN 300 328 V2.2.2 (2019-07)

## 1.3 Testing Location Information

Test Lab. : Sporton International Inc. Hsinhua Laboratory				
<input checked="" type="checkbox"/> Hsinhua (TAF: 3785)	ADD: No.52, Huaya 1st Rd., Guishan Dist., Taoyuan City 333411, Taiwan (R.O.C.)			
	TEL: 886-3-327-3456	FAX: 886-3-327-0973		
Test Condition	Test Site No.	Test Engineer	Test Environment	Test Date
RF Conducted	TH06-HY	Jin	22.6~26.4°C / 51~57%	24/Oct/2022
Radiated	05CH01-HY	Wayne	21.5~22.3°C / 53~58%	17/Oct/2022~18/Oct/2022
Receiver Blocking	DFS01-HY	Wayne	21~24.3°C / 56~58%	04/Nov/2022
<input type="checkbox"/> Wen 33rd.St. (TAF: 3785)	ADD: No.14-1, Ln. 19, Wen 33rd St., Guishan Dist., Taoyuan City 333010, Taiwan (R.O.C.)			
	TEL: 886-3-318-0787	FAX: 886-3-318-0287		

## 1.4 Measurement Uncertainty

ISO/IEC 17025 requires that an estimate of the measurement uncertainties associated with the emissions test results be included in the report. The measurement uncertainties given below are based on a 95% confidence level (based on a coverage factor (k=2))

Parameter	Uncertainty	Remark
RF Output Power	1.2 dB	Confidence levels of 95%
Power Spectral Density	1.2 dB	Confidence levels of 95%
Duty cycle, Tx-sequence, Tx-gap	1 %	Confidence levels of 95%
Adaptivity	1 %	Confidence levels of 95%
Occupied Channel Bandwidth	0.05 MHz	Confidence levels of 95%
Receiver Blocking	1 %	Confidence levels of 95%
Radiated Spurious Emissions	4.8 dB	Confidence levels of 95%



## 2 Test Configuration of EUT

### 2.1 Test Condition

Condition Item	Abbreviation/Remark	Remark
Tnom	Tnom	20°C
Tmin	Tmin	0°C
Tmax	Tmax	40°C
-	Vmax	230V



### 2.2 Test Channel Mode

Test Software Version	EspRFTestTool_v2.8
-----------------------	--------------------

Mode	Power Setting
BT-LE(1Mbps)	-
2402MHz	11
2440MHz	10
2480MHz	10
BT-LE(2Mbps)	-
2402MHz	11
2440MHz	10
2480MHz	10
BT-LE(125kbps)	-
2402MHz	11
2440MHz	10
2480MHz	10
BT-LE(500kbps)	-
2402MHz	11
2440MHz	10
2480MHz	10

### 2.3 The Worst Case Measurement Configuration

The Worst Case Mode for Following Conformance Tests	
<b>Test Items</b>	RF Output Power, Power Spectral Density, Occupied Channel Bandwidth Transmitter unwanted emissions in the OOB domain
<b>Test Condition</b>	Conducted measurement at transmit chains

The Worst Case Mode for Following Conformance Tests			
<b>Test Item</b>	Transmitter Unwanted Emissions in The Spurious Domain Receiver Spurious Emissions		
<b>Test Condition</b>	Radiated measurement		
<b>Operating Mode</b>	Transmit / Receive		
<b>1</b>	Adapter mode		
<b>Orthogonal Planes of EUT</b>	<b>X Plane</b>	<b>Y Plane</b>	<b>Z Plane</b>
			
<b>Worst Planes of EUT</b>		V	

The Worst Case Mode for Following Conformance Tests	
<b>Test Items</b>	Receiver Blocking
<b>Test Condition</b>	Conducted measurement at a receive chain

## 2.4 Accessories

Accessories				
AC Adapter	Brand Name	PHILIPS	Model Name	S024CSM1200200
	Power Rating	I/P: 100-240Vac, 0.6A, O/P: 12.0Vdc, 2.0A		
	Power Cord	1.25 meter, non-shielded cable, w/o ferrite core		
HDMI Cable	Signal Line	1.0 meter, shielded cable, w/o ferrite core		

Reminder: Regarding to more detail and other information, please refer to user manual.

## 2.5 Support Equipment

Support Equipment - RF Conducted				
No.	Equipment	Brand Name	Model Name	Remark
1	Notebook	HP	HSTNN-I42C	-
2	Adapter for NB	HP	HSTNN-CA40	-
3	USB Cable	CHANG YANG	E210567	-
4	CP2102 USB to UART Bridge	segger	CP2102	-

Support Equipment - Adaptivity				
No.	Equipment	Brand Name	Model Name	Remark
1	AP (Master)	Inteno	EG400	-
2	Notebook	DELL	Latitude E5570	-
3	CP2102 USB to UART Bridge	segger	CP2102	-

Support Equipment - Receiver Blocking				
No.	Equipment	Brand Name	Model Name	Remark
1	Shielding Box	H.C.E	G2424F-D	-
2	Notebook	DELL	Latitude E5570	-
3	CP2102 USB to UART Bridge	segger	CP2102	-

## 2.6 Test Setup Diagram

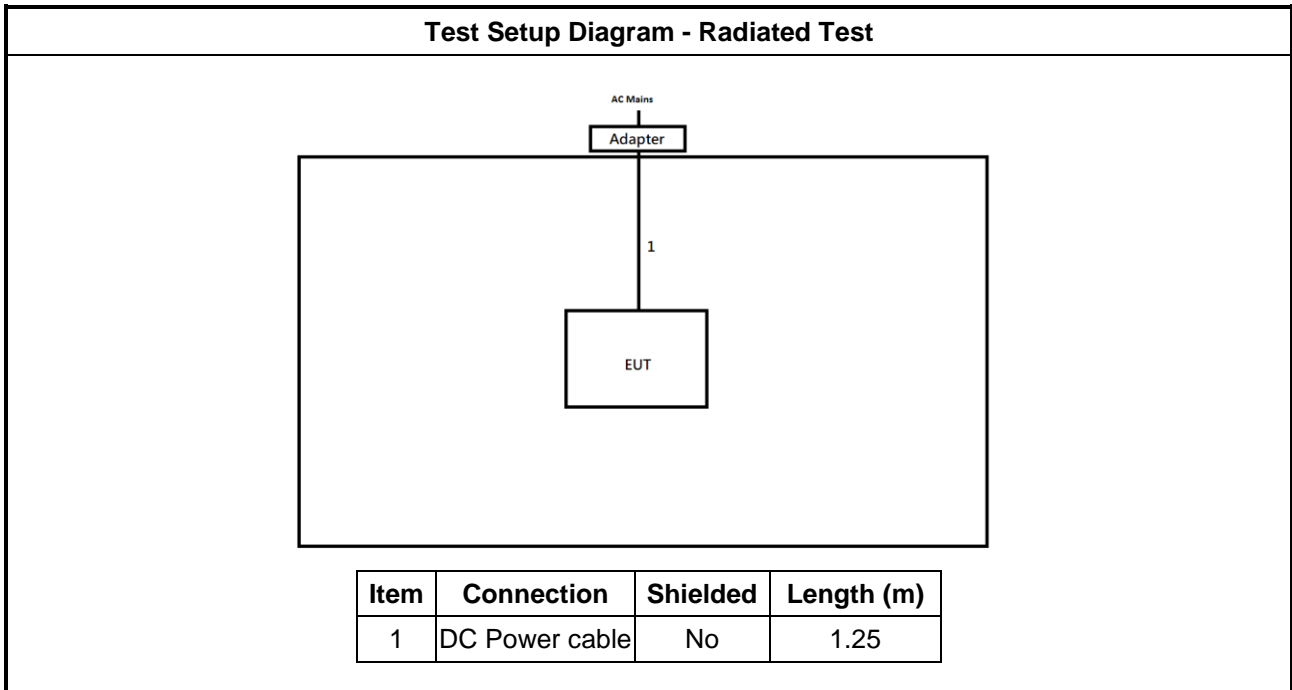

### 3 Transmitter Test Result

#### 3.1 RF Output Power

##### 3.1.1 RF Output Power Limit

RF Output Power Limit
<input checked="" type="checkbox"/> Mean equivalent isotropic radiated power (e.i.r.p.) ≤ 20 dBm

##### 3.1.2 Measuring Instruments

Refer a test equipment and calibration data table in this test report.

##### 3.1.3 Test Procedures

Test Method
<input checked="" type="checkbox"/> The measurements shall be performed at both normal environmental conditions and at the extremes of the operating temperature range.
<input checked="" type="checkbox"/> Refer as EN 300 328, clause 5.4.2.2.1 for conducted measurement.
<p>Step 1: Use a fast power sensor suitable for 2,4 GHz and capable of 1 MS/s.            Use the following settings:</p> <ul style="list-style-type: none"> <li>- Sample speed 1 MS/s or faster.</li> <li>- The samples shall represent the RMS power of the signal.</li> <li>- Measurement duration: For adaptive equipment, the measurement duration shall be long enough to ensure a minimum number of bursts (at least 10) are captured.</li> </ul> <p>NOTE 1: For adaptive equipment, to increase the measurement accuracy, a higher number of bursts may be used.</p> <p>Step 2: For conducted measurements on devices with multiple transmit chains:</p> <ul style="list-style-type: none"> <li>- Connect one power sensor to each transmit port for a synchronous measurement on all transmit ports.</li> <li>- Trigger the power sensors so that they start sampling at the same time.              Make sure the time difference between the samples of all sensors is less than half the time between the samples of all sensors is less than 500 ns.</li> <li>- For each instant in time, sum the power of the individual samples of all ports and store them. Use these stored samples in all following steps.</li> </ul> <p>Step 3: Find the start and stop times of each burst in the stored measurement samples.            NOTE 2: The start and stop times are defined as the points where the power is at least 30 dB the RMS burst power calculated in step 4.</p> <p>Step 4: Between the start and stop times of each individual burst calculate the RMS power over the burst using the formula below. Save these Pburst values, as well as the start and stop times for each burst.</p> $P_{burst} = \frac{1}{k} \sum_{n=1}^k P_{sample}(n)$ <p style="text-align: center;">with 'k' being the total number of samples and 'n' the actual sample number</p> <p>Step 5: The highest of all Pburst values (value "A" in dBm) will be used for maximum e.i.r.p. calculations.</p>

Step 6: Add the (stated) antenna assembly gain "G" in dBi of the individual antenna.  
 If applicable, add the additional beamforming gain "Y" in dB.  
 If more than one antenna assembly is intended for this power setting, the maximum overall antenna gain (G or G + Y) shall be used. The RF Output Power (P) shall be calculated using the formula below:  
 $P = A + G + Y$   
 This value, which shall comply with the limit given in clauses 4.3.2.2.3, shall be recorded in the test report.

Refer as EN 300 328, clause 5.4.2.2.2 for radiated measurement.

### 3.1.4 Test Setup

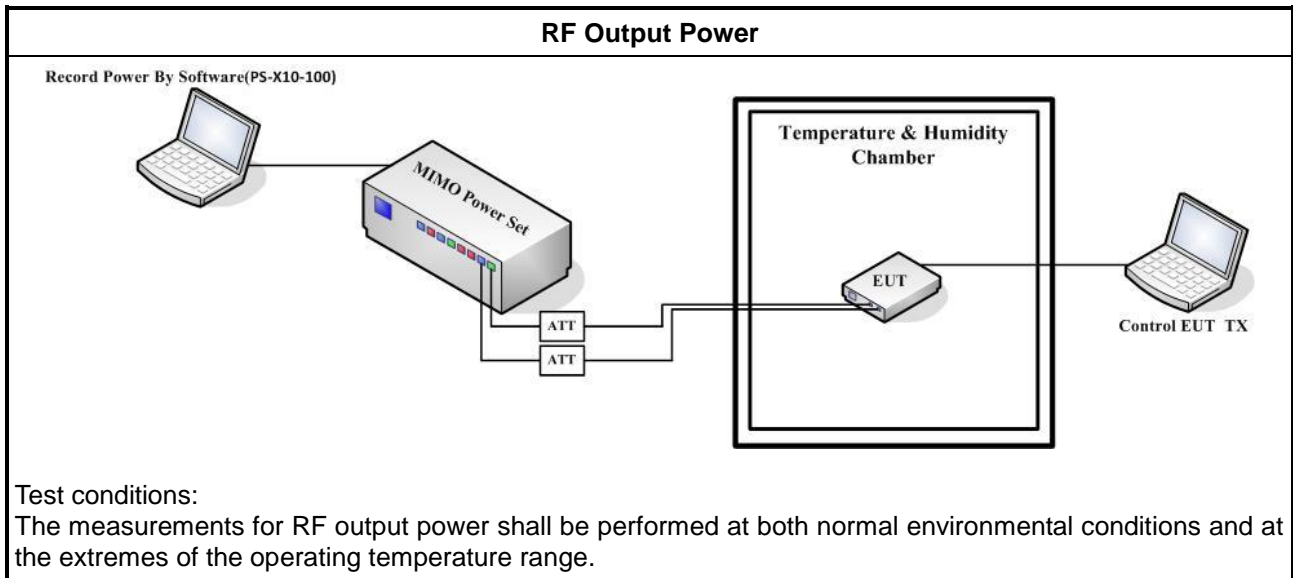

### 3.1.5 Test Result of RF Output Power

Refer as Appendix A

### 3.2 Power Spectral Density

#### 3.2.1 Power Spectral Density Limit

Power Density Limit	
<input checked="" type="checkbox"/>	Mean equivalent isotropic radiated power (e.i.r.p.) density $\leq 10$ dBm/MHz

#### 3.2.2 Measuring Instruments

Refer a test equipment and calibration data table in this test report.

#### 3.2.3 Test Procedures

Test Method	
<input checked="" type="checkbox"/>	Power spectral density shall be measured using one of the options below.
<input type="checkbox"/>	Option 1: For equipment with continuous and non-continuous transmissions. Refer as EN 300 328, clause 5.4.3.2.1.
<input checked="" type="checkbox"/>	Option 2: For equipment with continuous transmission capability or for equipment operating (or with the capability to operate) with a constant duty cycle (e.g. Frame Based equipment). Refer as EN 300 328, clause 5.4.3.2.1.
<input checked="" type="checkbox"/>	Refer as EN 300 328, clause 5.4.3.2.1 for conducted measurement.
<input type="checkbox"/>	Option 1:
Step 1:	Connect the UUT to the spectrum analyzer and use the following settings: - Start & Stop Frequency: 2400 MHz ~ 2483.5MHz - Resolution BW: 10 kHz - Video BW: 30 kHz - Sweep Points: > 8 350 - Detector Mode: RMS - Trace Mode: Max Hold - Sweep time: For non-continuous transmissions: 2 x Channel Occupancy Time x number of sweep points For continuous transmissions: 10s; the sweep time may be increased further until a value where the sweep time has no impact on the RMS value of the signal For non-continuous signals, wait for the trace to stabilize.
Step 2:	For conducted measurements on smart antenna systems using either operating mode 2 or operating mode 3 (see clause 5.3.2.2), repeat the measurement for each of the transmit ports. For each sampling point (frequency domain), add up the coincident power values (in mW) for the different transmit chains and use this as the new data set.
Step 3:	Add up the values for power for all the samples in the file using the formula below. $P_{Sum} = \sum_{n=1}^k P_{sample}(n)$ with 'k' being the total number of samples and 'n' the actual sample number
Step 4:	Normalize the individual values for power (in dBm) so that the sum is equal to the RF Output Power (e.i.r.p.) measured in clause 5.4.2 and save the corrected data. The following formulas can be used: $C_{Corr} = P_{Sum} - P_{e.i.r.p.}$ $P_{Samplecorr}(n) = P_{Sample}(n) - C_{Corr}$ with 'n' being the actual sample number

Step 5:	Starting from the first sample $P_{\text{Samplecorr}}(n)$ (lowest frequency), add up the power (in mW) of the following samples representing a 1 MHz segment and record the results for power and position (i.e. sample #1 to sample #100). This is the Power Spectral Density (e.i.r.p.) for the first 1 MHz segment which shall be recorded.
Step 6:	Shift the start point of the samples added up in step 5 by one sample and repeat the procedure in step 5 (i.e. sample #2 to #101).
Step 7:	Repeat step 6 until the end of the data set and record the Power Spectral Density values for each of the 1 MHz segments. From all the recorded results, the highest value is the maximum Power Spectral Density for the UUT. This value, which shall comply with the limit given in clause 4.3.2.3.3, shall be recorded in the test report.
<input checked="" type="checkbox"/> Option 2:	
Step 1:	Connect the UUT to the spectrum analyser and use the following settings: - Centre Frequency: The centre frequency of the channel under test - RBW: 1 MHz - VBW: 3 MHz - Frequency Span: 2 x Nominal Bandwidth (e.g. 40 MHz for a 20 MHz channel) - Detector Mode: Peak - Trace Mode: Max Hold
Step 2:	When the trace is complete, find the peak value of the power envelope and record the frequency.
Step 3:	Make the following changes to the settings of the spectrum analyser: - Centre Frequency: Equal to the frequency recorded in step 2 - Frequency Span: 3 MHz - RBW: 1 MHz - VBW: 3 MHz - Sweep Time: 1 minute - Detector Mode: RMS - Trace Mode: Max Hold
Step 4:	When the trace is complete, the trace shall be captured using the "Hold" or "View" option on the spectrum analyser. Find the peak value of the trace and place the analyser marker on this peak. This level is recorded as the highest mean power (power spectral density) $D$ in a 1 MHz band. Alternatively, where a spectrum analyser is equipped with a function to measure power spectral density, this function may be used to display the power spectral density $D$ in dBm / MHz. In case of conducted measurements on smart antenna systems operating in a mode with multiple transmit chains active simultaneously, the power spectral density of each transmit chain shall be measured separately to calculate the total power spectral density (value $D$ in dBm / MHz) for the UUT.
Step 5:	The maximum Power Spectral Density (PSD) e.i.r.p. is calculated from the above measured power spectral density $D$ , the observed Duty Cycle (DC) (see clause 5.4.2.2.1.3, step 4), the applicable antenna assembly gain $G$ in dBi and if applicable the beamforming gain $Y$ in dB, according to the formula below. This value shall be recorded in the test report. If more than one antenna assembly is intended for this power setting, the gain of the antenna assembly with the highest gain shall be used. $\text{PSD} = D + G + Y + 10 \times \log(1 / \text{DC}) \quad (\text{dBm} / \text{MHz})$
<input type="checkbox"/> Refer as EN 300 328, clause 5.4.3.2.2 for radiated measurement.	

### 3.2.4 Test Setup

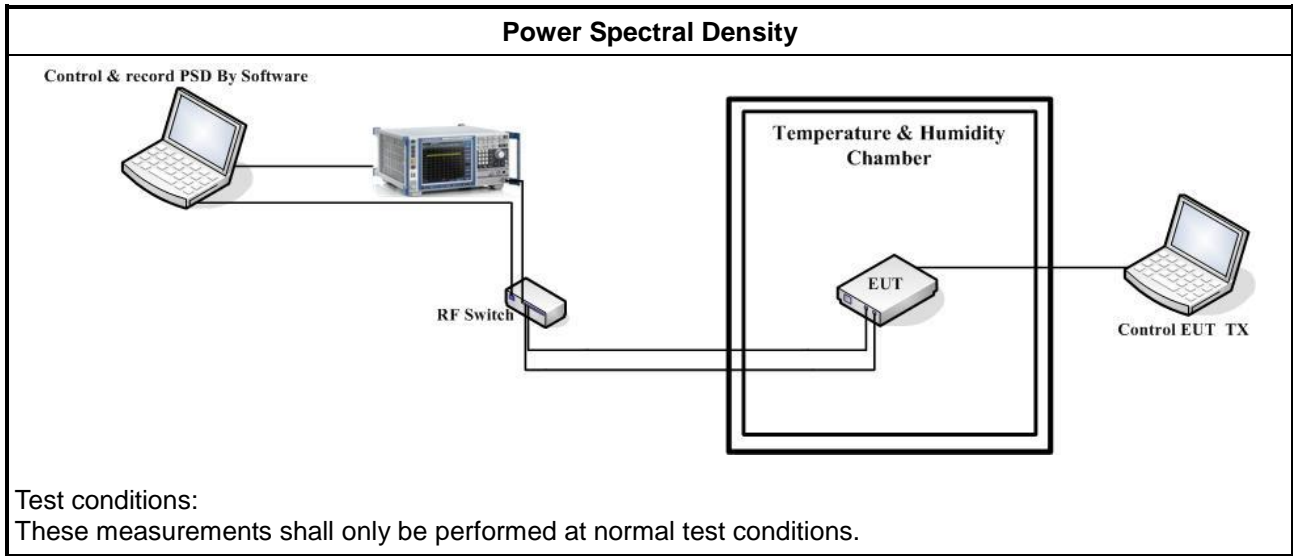

### 3.2.5 Test Result of Power Spectral Density

Refer as Appendix B

### 3.3 Occupied Channel Bandwidth

#### 3.3.1 Occupied Channel Bandwidth Limit

Occupied Channel Bandwidth Limit
<b>Type of Frequency Hopping Equipment:</b>
<input type="checkbox"/> Occupied Channel Bandwidth for each hopping frequency fall completely within 2.4 GHz – 2.4835 GHz.
<input type="checkbox"/> For non-adaptive equipment with e.i.r.p greater than 10 dBm, Occupied Channel Bandwidth $\leq$ 5 MHz.
<b>Type of Equipment Using Wide Band Modulations Other than FHSS:</b>
<input checked="" type="checkbox"/> Occupied Channel Bandwidth fall completely within 2.4 GHz – 2.4835 GHz.
<input type="checkbox"/> For non-adaptive equipment with e.i.r.p greater than 10 dBm, Occupied Channel Bandwidth $\leq$ 20 MHz.

#### 3.3.2 Measuring Instruments

Refer a test equipment and calibration data table in this test report.

#### 3.3.3 Test Procedures

Test Method
<input checked="" type="checkbox"/> Refer as EN 300 328, clause 5.4.7.2.1 for conducted measurement.
<p>Step 1: Connect the UUT to the spectrum analyzer and use the following settings:</p> <ul style="list-style-type: none"> <li>- Centre Frequency : The centre frequency of the channel under test.</li> <li>- Resolution BW : <math>\sim</math> 1 % of the span without going below 1 %.</li> <li>- Video BW : <math>3 \times</math> RBW.</li> <li>- Frequency Span : <math>2 \times</math> Occupied Channel Bandwidth (e.g. 40 MHz for a 20 MHz channel)</li> <li>- Detector Mode : RMS.</li> <li>- Trace Mode : Max Hold.</li> <li>- Sweep Time : 1s.</li> </ul> <p>Step 2: Wait until the trace is completed. Find the peak value of the trace and place the analyzer marker on this peak.</p> <p>Step 3: Use the 99 % bandwidth function of the spectrum analyzer to measure the Occupied Channel Bandwidth of the UUT ,This value shall be recorded. NOTE: Make sure that the power envelope is sufficiently above the noise floor of the analyzer to avoid the noise signals left and right from the power envelope being taken into account by this measurement.</p>
<input type="checkbox"/> Refer as EN 300 328, clause 5.4.7.2.2 for radiated measurement.

### 3.3.4 Test Setup

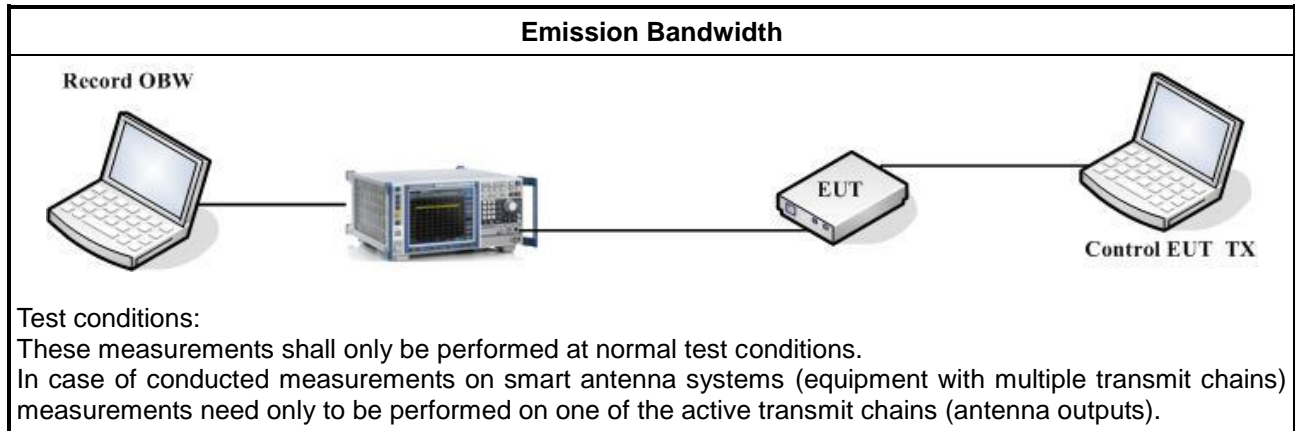

### 3.3.5 Test Result of Occupied Channel Bandwidth

Refer as Appendix C

### 3.4 Transmitter Unwanted Emissions in the Out-of-band Domain

#### 3.4.1 Transmitter Unwanted Emissions in the Out-of-band Domain Limit

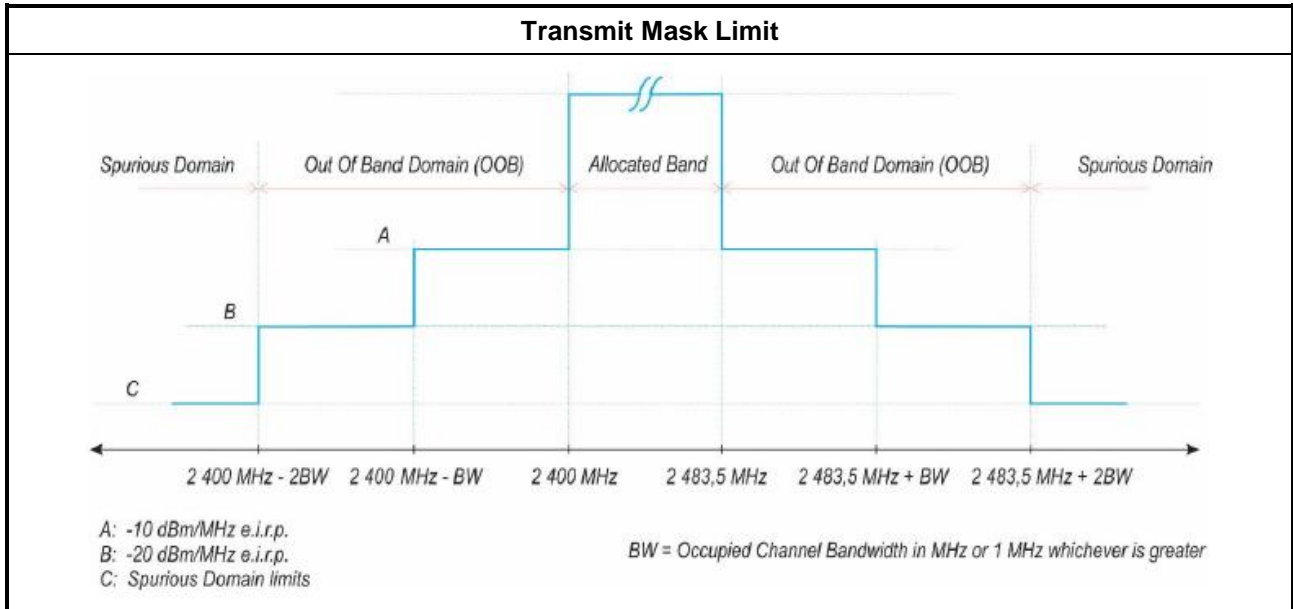

#### 3.4.2 Measuring Instruments

Refer a test equipment and calibration data table in this test report.

#### 3.4.3 Test Procedures

Test Method
<input checked="" type="checkbox"/> Refer as EN 300 328, clause 5.4.8.2.1 for conducted measurement.
<p>Step 1: Connect the UUT to the spectrum analyzer and use the following settings:</p> <ul style="list-style-type: none"> <li>- Centre Frequency : 2 484 MHz</li> <li>- Span : 0 Hz</li> <li>- Resolution BW : 1 MHz</li> <li>- Filter mode : Channel filter</li> <li>- Video BW : 3MHz</li> <li>- Detector Mode : RMS</li> <li>- Trace Mode : Clear / Write</li> <li>- Sweep Mode : Continuous</li> <li>- Sweep Points : Sweep Time [s] / (1 <math>\mu</math>s) or 5 000 whichever is greater</li> <li>- Trigger Mode : Video trigger</li> <li>- Sweep Time : &gt; 120 % of the duration of the longest burst detected during the measurement of the RF Output Power.</li> </ul> <p>NOTE 1: In case video triggering is not possible, an external trigger source may be used.</p>

Step 2: (segment 2 483,5 MHz to 2 483,5 MHz + BW)

- Adjust the trigger level to select the transmissions with the highest power level.
- For frequency hopping equipment operating in a normal hopping mode, the different hops will result in signal bursts with different power levels. In this case the burst with the highest power level shall be selected.
- Set a window (start and stop lines) to match with the start and end of the burst and in which the RMS power shall be measured using the Time Domain Power function.
- Select RMS power to be measured within the selected window and note the result which is the RMS power within this 1 MHz segment (2 483,5 MHz to 2 484,5 MHz). Compare this value with the applicable limit provided by the mask.
- Increase the centre frequency in steps of 1 MHz and repeat this measurement for every 1 MHz segment within the range 2 483,5 MHz to 2 483,5 MHz + BW. The centre frequency of the last 1 MHz segment shall be set to 2 483,5 MHz + BW - 0,5 MHz (which means this may partly overlap with the previous 1 MHz segment).

Step 3: (segment 2 483,5 MHz + BW to 2 483,5 MHz + 2BW)

- Change the centre frequency of the analyzer to 2 484 MHz + BW and perform the measurement for the first 1 MHz segment within range 2 483,5 MHz + BW to 2 483,5 MHz + 2BW. Increase the centre frequency in 1 MHz steps and repeat the measurements to cover this whole range. The centre frequency of the last 1 MHz segment shall be set to 2 483,5 MHz + 2 BW - 0,5 MHz.

Step 4: (segment 2 400 MHz - BW to 2 400 MHz)

- Change the centre frequency of the analyzer to 2 399,5 MHz and perform the measurement for the first 1 MHz segment within range 2 400 MHz - BW to 2 400 MHz. Reduce the centre frequency in 1 MHz steps and repeat the measurements to cover this whole range. The centre frequency of the last 1 MHz segment shall be set to 2 400 MHz - 2BW + 0,5 MHz.

Step 5: (segment 2 400 MHz - 2BW to 2 400 MHz - BW)

- Change the centre frequency of the analyzer to 2 399,5 MHz - BW and perform the measurement for the first 1 MHz segment within range 2 400 MHz - 2BW to 2 400 MHz - BW. Reduce the centre frequency in 1 MHz steps and repeat the measurements to cover this whole range. The centre frequency of the last 1 MHz segment shall be set to 2 400 MHz - 2BW + 0,5 MHz.

Step 6: - In case of conducted measurements on equipment with a single transmit chain, the declared antenna assembly gain "G" in dBi shall be added to the results for each of the 1 MHz segments and compared with the limits provided by the mask given in figures 1 or 3. If more than one antenna assembly is intended for this power setting, the antenna with the highest gain shall be considered.

- In case of conducted measurements on smart antenna systems (equipment with multiple transmit chains), the measurements need to be repeated for each of the active transmit chains. The declared antenna assembly gain "G" in dBi for a single antenna shall be added to these results. If more than one antenna assembly is intended for this power setting, the antenna with the highest gain shall be considered. Comparison with the applicable limits shall be done using any of the options given below:

- Option 1: the results for each of the transmit chains for the corresponding 1 MHz segments shall be added. The additional beamforming gain "Y" in dB shall be added as well and the resulting values compared with the limits provided by the mask given in figures 1 or 3.
- Option 2: the limits provided by the mask given in figures 1 or 3 shall be reduced by  $10 \times \log_{10}(Ach)$  and the additional beamforming gain "Y" in dB. The results for each of the transmit chains shall be individually compared with these reduced limits.

NOTE 2: Ach refers to the number of active transmit chains. It shall be recorded whether the equipment complies with the mask provided in figures 1 or 3.

Refer as EN 300 328, clause 5.4.8.2.2 for radiated measurement.

### 3.4.4 Test Setup

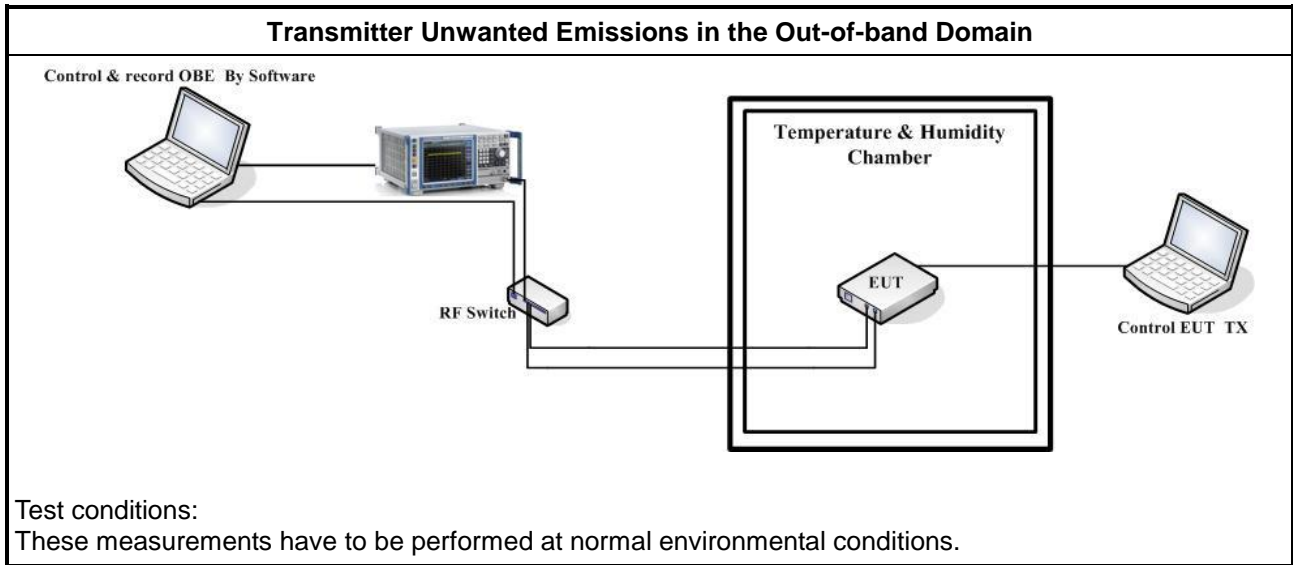

### 3.4.5 Test Result of Transmitter Unwanted Emissions in the Out-of-band Domain

Refer as Appendix D

### 3.5 Transmitter Unwanted Emissions in the Spurious Domain

#### 3.5.1 Transmitter Unwanted Emissions in the Spurious Domain Limit

Frequency Range	Maximum Power	Bandwidth
30 MHz to 47 MHz	-36 dBm	100 kHz
47 MHz to 74 MHz	-54 dBm	100 kHz
74 MHz to 87,5 MHz	-36 dBm	100 kHz
87,5 MHz to 118 MHz	-54 dBm	100 kHz
118 MHz to 174 MHz	-36 dBm	100 kHz
174 MHz to 230 MHz	-54 dBm	100 kHz
230 MHz to 470 MHz	-36 dBm	100 kHz
470 MHz to 694 MHz	-54 dBm	100 kHz
694 MHz to 1 GHz	-36 dBm	100 kHz
1 GHz to 12,75 GHz	-30 dBm	1 MHz

Note 1: spurious domain  $\leq (2400 \text{ MHz} - 2N)$  and spurious domain  $\geq (2483.5 \text{ MHz} + 2N)$ ;  
 $N = \text{MAX}(1, \text{Occupied Channel Bandwidth}) \text{ MHz}$

#### 3.5.2 Measuring Instruments

Refer a test equipment and calibration data table in this test report.

**3.5.3 Test Procedures**

<b>Test Method</b>	
<input type="checkbox"/>	Refer as EN 300 328, clause 5.4.9.2.1 for conducted measurement. Conducted spurious emissions and radiated by the cabinet with the antenna connector(s) terminated by a specified load (cabinet radiation).
<input checked="" type="checkbox"/>	Refer as EN 300 328, clause 5.4.9.2.2 for radiated measurement.
<p>Pre-scan: The test procedure below shall be used to identify potential unwanted emissions of the UUT.</p> <p>Step 1: The sensitivity of the spectrum analyzer should be such that the noise floor is at least 12 dB below the limits given in tables 4 or 12.</p> <p>Step 2: The emissions over the range 30 MHz to 1 000 MHz shall be identified.            Spectrum analyzer settings :            - Resolution bandwidth : 100 kHz            - Video bandwidth : 300 kHz            - Detector mode : Peak            - Filter type : 3 dB (Gaussian)            - Trace Mode : Max Hold            - Sweep Points : ≥ 19 400            NOTE 1: For spectrum analyzers not supporting this high number of sweep points, the frequency band may need to be segmented.            - Sweep time:            • For non-continuous transmissions (duty cycle less than 100 %), the sweep time shall be sufficiently long, such that for each 100 kHz frequency step, the measurement time is greater than two transmissions of the UUT.            • For Frequency Hopping equipment operating in a normal operating (hopping not disabled) mode, the sweep time shall be further increased to capture multiple transmissions on the same hopping frequency in different hopping sequences.            Allow the trace to stabilize. Any emissions identified during the sweeps above and that fall within the 6 dB range below the applicable limit or above, shall be individually measured using the procedure in clause 5.4.9.2.1.3 and compared to the limits given in tables 4 or 12.</p> <p>Step 3: The emissions over the range 1 GHz to 12,75 GHz shall be identified.            Spectrum analyzer settings:            - Resolution bandwidth : 1 MHz            - Video bandwidth : 3 MHz            - Filter type : 3 dB (Gaussian)            - Detector mode : Peak            - Trace Mode : Max Hold            - Sweep Points : ≥ 23 500            NOTE 2: For spectrum analyzers not supporting this high number of sweep points, the frequency band may need to be segmented.            - Sweep time:            • For non-continuous transmissions (duty cycle less than 100 %), the sweep time shall be sufficiently long, such that for each 1 MHz frequency step, the measurement time is greater than two transmissions of the UUT.            • For Frequency Hopping equipment operating in a normal operating (hopping not disabled) mode, the sweep time shall be further increased to capture multiple transmissions on the same hopping frequency in different hopping sequences.            Allow the trace to stabilize. Any emissions identified during the sweeps above that fall within the 6 dB range below the applicable limit or above, shall be individually measured using the procedure in clause 5.4.9.2.1.3 and compared to the limits given in tables 4 or 12.            Frequency Hopping equipment may generate a block (or several blocks) of spurious emissions anywhere within the spurious domain. If this is the case, only the highest peak of each block of emissions shall be measured using the procedure in clause 5.4.9.2.1.3.</p>	

Step 4: In case of conducted measurements on smart antenna systems (equipment with multiple transmit chains), the steps 2 and 3 need to be repeated for each of the active transmit chains (Ach). The limits used to identify emissions during this pre-scan need to be reduced with  $10 \times \log_{10}(\text{Ach})$  (number of active transmit chains).

Measurement of the emissions identified during the pre-scan

Step 1: The level of the emissions shall be measured using the following spectrum analyzer settings:

- Measurement Mode : Time Domain Power
- Centre Frequency : Frequency of emission identified during the pre-scan
- Resolution Bandwidth : 100 kHz (< 1 GHz) / 1 MHz (> 1 GHz)
- Video Bandwidth : 300 kHz (< 1 GHz) / 3 MHz (> 1 GHz)
- Frequency Span : Zero Span
- Sweep mode : Single Sweep
- Sweep time : >120 % of the duration of the longest burst detected during the measurement of the RF Output Power
- Sweep points : Sweep time [ $\mu\text{s}$ ] / (1  $\mu\text{s}$ ) with a maximum of 30 000
- Trigger : Video (burst signals) or Manual (continuous signals)
- Detector : RMS

Step 2: Set a window where the start and stop indicators match the start and end of the burst with the highest level and record the value of the power measured within this window. If the spurious emission to be measured is a continuous transmission, the measurement window shall be set to match the start and stop times of the sweep.

Step 3: In case of conducted measurements on smart antenna systems (equipment with multiple transmit chains), step 2 needs to be repeated for each of the active transmit chains (Ach). Sum the measured power (within the observed window) for each of the active transmit chains.

Step 4: The value defined in step 3 shall be compared to the limits defined in tables 4 or 12.

### 3.5.4 Test Setup

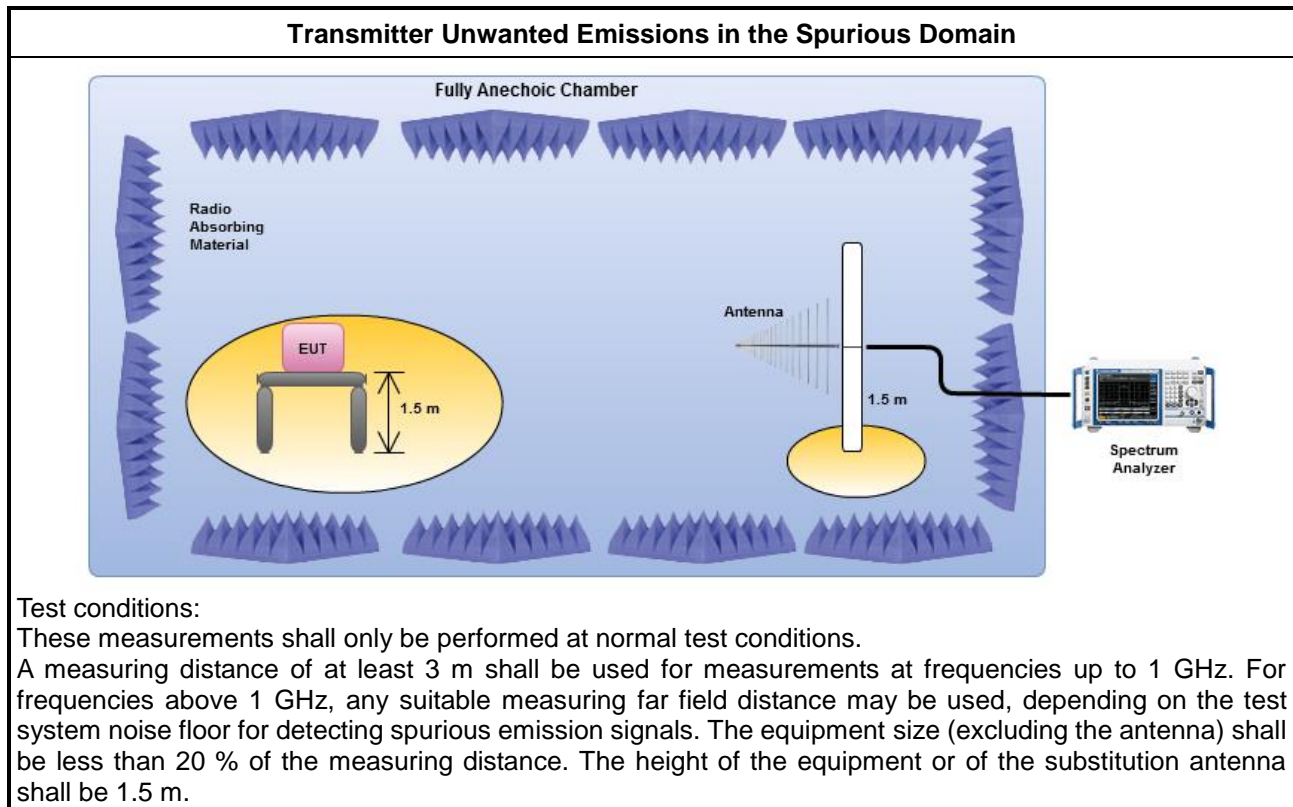



### **3.5.5 Transmitter Radiated Unwanted Emissions**

Refer as Appendix E



## **4 Receiver Test Result**

### **4.1 Receiver Spurious Emissions**

#### **4.1.1 Receiver Spurious Emissions Limit**

<b>Frequency Range</b>	<b>Maximum Power</b>	<b>Bandwidth</b>
30 MHz to 1 GHz	-57 dBm	100 kHz
1 GHz to 12,75 GHz	-47 dBm	1 MHz

#### **4.1.2 Measuring Instruments**

Refer a test equipment and calibration data table in this test report.

**4.1.3 Test Procedures**

<b>Test Method</b>	
<input type="checkbox"/>	Refer as EN 300 328, clause 5.4.10.2.1 for conducted measurement. Conducted spurious emissions and radiated by the cabinet with the antenna connector(s) terminated by a specified load (cabinet radiation).
<input checked="" type="checkbox"/>	Refer as EN 300 328, clause 5.4.10.2.2 for radiated measurement.
<p>Pre-scan: The test procedure below shall be used to identify potential unwanted emissions of the UUT.</p> <p>Step 1: The sensitivity of the spectrum analyzer should be such that the noise floor is at least 12 dB below the limits given in tables 5 or 13.</p> <p>Step 2: The emissions over the range 30 MHz to 1 000 MHz shall be identified.            Spectrum analyzer settings :            - Resolution bandwidth : 100 kHz            - Video bandwidth : 300 kHz            - Filter type : 3 dB (Gaussian)            - Detector mode : Peak            - Trace Mode : Max Hold            - Sweep Points : ≥ 19 400            NOTE 1: For spectrum analyzers not supporting this high number of sweep points, the frequency band may need to be segmented.            - Sweep time : Auto            Allow the trace to stabilize. Any emissions identified during the sweeps above and that fall within the 6 dB range below the applicable limit or above, shall be individually measured using the procedure in clause 5.4.10.2.1.3 and compared to the limits given in tables 5 or 13.</p> <p>Step 3: The emissions over the range 1 GHz to 12,75 GHz shall be identified.            Spectrum analyzer settings:            - Resolution bandwidth : 1 MHz            - Video bandwidth : 3 MHz            - Filter type : 3 dB (Gaussian)            - Detector mode : Peak            - Trace Mode : Max Hold            - Sweep Points : ≥ 23 500            NOTE 2: For spectrum analyzers not supporting this high number of sweep points, the frequency band may need to be segmented.            - Sweep time: Auto            Allow the trace to stabilize. Any emissions identified during the sweeps above that fall within the 6 dB range below the applicable limit or above, shall be individually measured using the procedure in clause 5.4.10.2.1.3 and compared to the limits given in tables 5 or 13.            Frequency Hopping equipment may generate a block (or several blocks) of spurious emissions anywhere within the spurious domain. If this is the case, only the highest peak of each block of emissions shall be measured using the procedure in clause 5.4.10.2.1.3.</p>	

- Step 4: In case of conducted measurements on smart antenna systems (equipment with multiple transmit chains), the steps 2 and 3 need to be repeated for each of the active transmit chains (Ach). The limits used to identify emissions during this pre-scan need to be reduced with  $10 \times \log_{10}$  (Ach) (number of active transmit chains).
- Measurement of the emissions identified during the pre-scan
- Step 1: The level of the emissions shall be measured using the following spectrum analyzer settings:
- Measurement Mode : Time Domain Power
  - Centre Frequency : Frequency of emission identified during the pre-scan
  - Resolution Bandwidth : 100 kHz (< 1 GHz) / 1 MHz (> 1 GHz)
  - Video Bandwidth : 300 kHz (< 1 GHz) / 3 MHz (> 1 GHz)
  - Frequency Span : Zero Span
  - Sweep mode : Single Sweep
  - Sweep time : 30 ms
  - Sweep Point :  $\geq 30\ 000$
  - Trigger : Video (for burst signals) or Manual (for continuous signals)
  - Detector : RMS
- Step 2: Set a window where the start and stop indicators match the start and end of the burst with the highest level and record the value of the power measured within this window. If the spurious emission to be measured is a continuous transmission, the measurement window shall be set to the start and stop times of the sweep.
- Step 3: In case of conducted measurements on smart antenna systems (equipment with multiple receive chains), step 2 needs to be repeated for each of the active receive chains (Ach). Sum the measured power (within the observed window) for each of the active receive chains
- Step 4: The value defined in step 3 shall be compared to the limits defined in tables 5 or 13.

#### 4.1.4 Test Setup

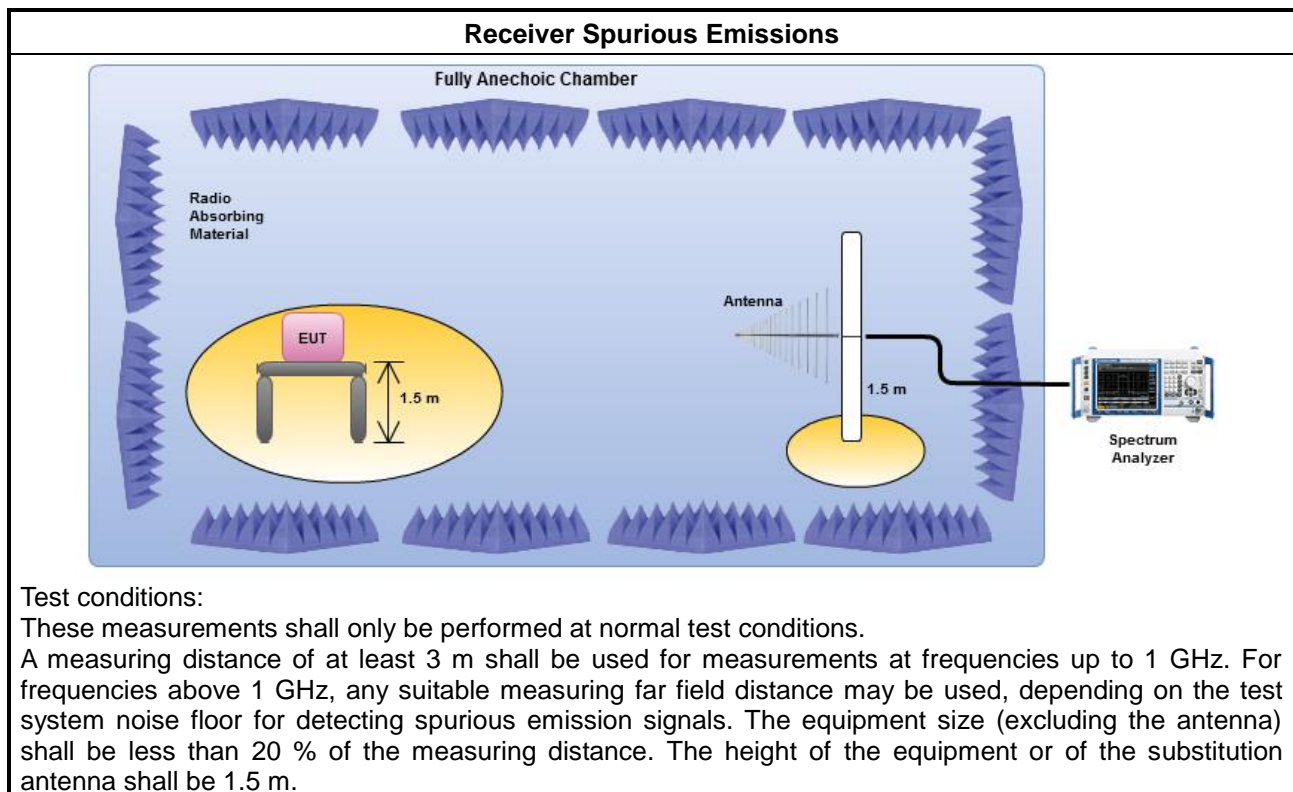



#### **4.1.5 Receiver Radiated Spurious Emissions**

Refer as Appendix F

## 5 Receiver Blocking Test Result

### 5.1 Receiver Blocking

#### 5.1.1 Receiver Blocking Limit

Receiver Blocking Limit	
<input type="checkbox"/>	Receiver Category 1: Adaptive equipment with a maximum RF output power greater than 10 dBm e.i.r.p. shall be considered as receiver category 1 equipment.
<input checked="" type="checkbox"/>	Receiver Category 2: Non-adaptive equipment with a Medium Utilization (MU) factor greater than 1 % and less than or equal to 10 % or adaptive equipment with a maximum RF output power of 10 dBm e.i.r.p. shall be considered as receiver category 2 equipment.
<input type="checkbox"/>	Receiver Category 3: Non-adaptive equipment with a maximum Medium Utilization (MU) factor of 1 % or adaptive equipment with a maximum RF output power of 0 dBm e.i.r.p. shall be considered as receiver category 3 equipment.

Table 1: Receiver Blocking Parameters for Receiver Category 1 Equipment			
Wanted signal mean power from companion device (dBm) (see notes 1 and 4)	Blocking signal frequency (MHz)	Blocking signal power (dBm) (see note 2)	Type of blocking signal
(-133 dBm + 10 × log <sub>10</sub> (OCBW)) or -68 dBm whichever is less (see note 2)	2 380 2 504	-34	CW
(-139 dBm + 10 × log <sub>10</sub> (OCBW)) or -74 dBm whichever is less (see note 3)	2 300, 2 330 2 360, 2 524 2 584, 2 674		
<p>NOTE 1: OCBW is in Hz.</p> <p>NOTE 2: In case of radiated measurements using a companion device and the level of the wanted signal from the companion device cannot be determined, a relative test may be performed using a wanted signal up to P<sub>min</sub> + 26 dB where P<sub>min</sub> is the minimum level of wanted signal required to meet the minimum performance criteria as defined in clause 4.3.1.12.3 in the absence of any blocking signal.</p> <p>NOTE 3: In case of radiated measurements using a companion device and the level of the wanted signal from the companion device cannot be determined, a relative test may be performed using a wanted signal up to P<sub>min</sub> + 20 dB where P<sub>min</sub> is the minimum level of wanted signal required to meet the minimum performance criteria as defined in clause 4.3.1.12.3 in the absence of any blocking signal.</p> <p>NOTE 4: The level specified is the level at the UUT receiver input assuming a 0 dBi antenna assembly gain. In case of conducted measurements, this level has to be corrected for the (in-band) antenna assembly gain (G). In case of radiated measurements, this level is equivalent to a power flux density (PFD) in front of the UUT antenna with the UUT being configured/positioned as recorded in clause 5.4.3.2.2.</p>			

<b>Table 2: Receiver Blocking Parameters for Receiver Category 2 Equipment</b>			
<b>Wanted signal mean power from companion device (dBm) (see notes 1 and 3)</b>	<b>Blocking signal frequency (MHz)</b>	<b>Blocking signal power (dBm) (see note 2)</b>	<b>Type of blocking signal</b>
(-139 dBm + 10 × log <sub>10</sub> (OCBW) + 10 dB) or (-74 dBm + 10 dB) whichever is less (see note 2)	2 380, 2 504 2 300, 2 584	-34	CW
<p>NOTE 1: OCBW is in Hz.            NOTE 2: In case of radiated measurements using a companion device and the level of the wanted signal from the companion device cannot be determined, a relative test may be performed using a wanted signal up to P<sub>min</sub> + 26 dB where P<sub>min</sub> is the minimum level of wanted signal required to meet the minimum performance criteria as defined in clause 4.3.1.12.3 in the absence of any blocking signal.            NOTE 3: The level specified is the level at the UUT receiver input assuming a 0 dBi antenna assembly gain. In case of conducted measurements, this level has to be corrected for the (in-band) antenna assembly gain (G). In case of radiated measurements, this level is equivalent to a power flux density (PFD) in front of the UUT antenna with the UUT being configured/positioned as recorded in clause 5.4.3.2.2.</p>			

<b>Table 3: Receiver Blocking Parameters for Receiver Category 3 Equipment</b>			
<b>Wanted signal mean power from companion device (dBm) (see notes 1 and 3)</b>	<b>Blocking signal frequency (MHz)</b>	<b>Blocking signal power (dBm) (see note 2)</b>	<b>Type of blocking signal</b>
(-139 dBm + 10 × log <sub>10</sub> (OCBW) + 20 dB) or (-74 dBm + 20 dB) whichever is less (see note 2)	2 380, 2 504 2 300, 2 584	-34	CW
<p>NOTE 1: OCBW is in Hz.            NOTE 2: In case of radiated measurements using a companion device and the level of the wanted signal from the companion device cannot be determined, a relative test may be performed using a wanted signal up to P<sub>min</sub> + 30 dB where P<sub>min</sub> is the minimum level of wanted signal required to meet the minimum performance criteria as defined in clause 4.3.1.12.3 in the absence of any blocking signal.            NOTE 3: The level specified is the level at the UUT receiver input assuming a 0 dBi antenna assembly gain. In case of conducted measurements, this level has to be corrected for the (in-band) antenna assembly gain (G). In case of radiated measurements, this level is equivalent to a power flux density (PFD) in front of the UUT antenna with the UUT being configured/positioned as recorded in clause 5.4.3.2.2.</p>			

**5.1.2 Measuring Instruments**

Refer a test equipment and calibration data table in this test report.

**5.1.3 Test Procedures**

<b>Test Method</b>	
<input checked="" type="checkbox"/>	Refer as EN 300 328, clause 5.4.11.2.1 for conducted measurement.
<input checked="" type="checkbox"/>	For systems using multiple receive chains only one chain (antenna port) need to be tested. All other receiver inputs shall be terminated. For non-frequency hopping equipment, the UUT shall be set to the lowest operating channel.
	Step 1 The blocking signal generator is set to the first frequency as defined in the appropriate table corresponding to the receiver category and type of equipment.
	Step 2 With the blocking signal generator switched off, a communication link is established between the UUT and the associated companion device using the test setup shown in figure 6.  Unless the option provided in note 2 of the applicable table referred to in clause 5.4.11.2.1 is used, the level of the wanted signal shall be set to the value provided in the table corresponding to the receiver category and type of equipment. The test procedure defined in clause 5.4.2, and more in particular clause 5.4.2.2.1.2, can be used to measure the (conducted) level of the wanted signal however no correction shall be made for antenna gain of the companion device (step 6 in clause 5.4.2.2.1.2 shall be ignored). This level may be measured directly at the output of the companion device and a correction is made for the coupling loss into the UUT. The actual level for the wanted signal shall be recorded in the test report.  When the option provided in note 2 of the applicable table referred to in clause 5.4.11.2.1 is used, the attenuation of the variable attenuator shall be increased in 1 dB steps to a value at which the minimum performance criteria as specified in clause 4.3.1.12.3 or clause 4.3.2.11.3 is still met. The resulting level for the wanted signal at the input of the UUT is Pmin. This signal level (Pmin) is increased by the value provided in note 2 of the applicable table corresponding to the receiver category and type of equipment.
	Step 3 The blocking signal at the UUT is set to the level provided in the table corresponding to the receiver category and type of equipment.
	Step 4 Repeat step 2 and step 3 for each remaining combination of frequency and level for the blocking signal as provided in the table corresponding to the receiver category and type of equipment.  For non-FHSS equipment, repeat step 2 to step 4 with the UUT operating at the highest operating channel on which the blocking test has to be performed (see clause 5.4.11.1).  It shall be assessed and recorded in the test report whether the UUT complies with the Receiver Blocking requirement.
<input type="checkbox"/>	Refer as EN 300 328, clause 5.4.11.2.2 for radiated measurement.

### 5.1.4 Test Setup

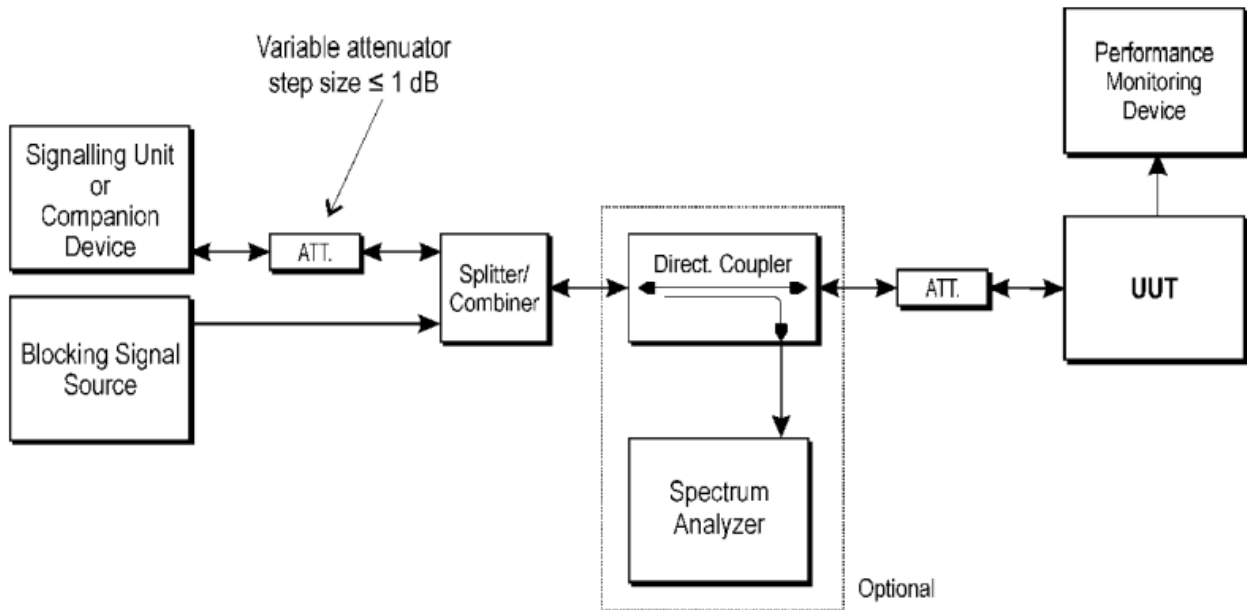

### 5.1.5 Test Result of Receiver Blocking

Refer as Appendix G



## 6 Test Equipment and Calibration Data

### Instrument for Conducted Test

Instrument	Manufacturer /Brand	Model No.	Serial No.	Spec.	Calibration Date	Calibration Due Date
Signal Analyzer	R&S	FSV 40	101013	10Hz~40GHz	01/Apr/2022	31/Mar/2023
Programmable Temp. & Humi. Chamber	Giant Force	GTH-225-40-C P-AR	MAA1611-005	-40~100°C	15/Dec/2021	14/Dec/2022
Signal Generator	Keysight	N5171B	MY53051240	9kHz~6GHz	24/Nov/2021	23/Nov/2022
USB Wideband Power Sensor	Agilent	U2021XA	MY54320011	50MHz~18GHz	17/Aug/2022	16/Aug/2023
USB Wideband Power Sensor	Agilent	U2021XA	MY54320013	50MHz~18GHz	17/Aug/2022	16/Aug/2023
SENSE-300328_FS	Sporton	V5.10.7.13	N/A	N/A	N/A	N/A

### Instrument for Radiated Test

Instrument	Manufacturer /Brand	Model No.	Serial No.	Spec.	Calibration Date	Calibration Due Date
Signal Analyzer	R&S	FSV40	101514	10Hz~40GHz	04/May/2022	03/May/2023
Amplifier	Agilent	8447D	2944A11146	100kHz~1.3GHz	01/Sep/2022	31/Aug/2023
Microwave Preamplifier	EMC INSTRUMENT	EMC051845BE	980241	1GHz~18GHz	13/May/2022	12/May/2023
Bilog Antenna & 6dB Attenuator	SCHAFFNER	CBL6111C & N-6-06	2737 & AT-N0603	30MHz~1GHz	28/Aug/2022	27/Aug/2023
Double Ridged Guide Horn Antenna	ETS-LINDGREN	3117	00091920	1GHz~18GHz	25/Nov/2021	24/Nov/2022
RF Cable	Jye Bao	SUOFLEX 104	CB001+F1403+SN329367/4	30MHz~1GHz	16/Mar/2022	15/Mar/2023
RF Cable	HUBER+SUHNER	SUOFLEX 104	SN345669/4+MY34919/4	1GHz~40GHz	16/Mar/2022	15/Mar/2023
SENSE-300328_FS	Sporton	V5.10.7.13	N/A	N/A	N/A	N/A

### Instrument for Receiver Blocking Test

Instrument	Manufacturer /Brand	Model No.	Serial No.	Spec.	Calibration Date	Calibration Due Date
Wireless connectivity tester	R&S	CMW270	100855	70MHz ~6GHz	24/Nov/2021	23/Nov/2022
Signal Generator	Keysight	N5171B	MY53051240	9kHz~6GHz	24/Nov/2021	23/Nov/2022



Summary

Mode	EIRP (dBm)	EIRP (W)
2.4-2.4835GHz	-	-
BT-LE(1Mbps)	9.82	0.00959
BT-LE(2Mbps)	9.95	0.00989
BT-LE(125kbps)	9.99	0.00998
BT-LE(500kbps)	9.82	0.00959

Result

Mode	Result	Gain (dBi)	Sum (dBm)	EIRP (dBm)	EIRP Lim. (dBm)
BT-LE(1Mbps)	-	-	-	-	-
2402MHz_Tnom	Pass	2.40	7.39	9.79	20.00
2402MHz_Tmin	Pass	2.40	7.15	9.55	20.00
2402MHz_Tmax	Pass	2.40	7.42	9.82	20.00
2440MHz_Tnom	Pass	2.40	5.33	7.73	20.00
2440MHz_Tmin	Pass	2.40	5.44	7.84	20.00
2440MHz_Tmax	Pass	2.40	5.56	7.96	20.00
2480MHz_Tnom	Pass	2.40	6.04	8.44	20.00
2480MHz_Tmin	Pass	2.40	5.86	8.26	20.00
2480MHz_Tmax	Pass	2.40	4.92	7.32	20.00
BT-LE(2Mbps)	-	-	-	-	-
2402MHz_Tnom	Pass	2.40	7.50	9.90	20.00
2402MHz_Tmin	Pass	2.40	7.54	9.94	20.00
2402MHz_Tmax	Pass	2.40	7.55	9.95	20.00
2440MHz_Tnom	Pass	2.40	5.45	7.85	20.00
2440MHz_Tmin	Pass	2.40	5.59	7.99	20.00
2440MHz_Tmax	Pass	2.40	5.69	8.09	20.00
2480MHz_Tnom	Pass	2.40	6.09	8.49	20.00
2480MHz_Tmin	Pass	2.40	6.21	8.61	20.00
2480MHz_Tmax	Pass	2.40	6.27	8.67	20.00
BT-LE(125kbps)	-	-	-	-	-
2402MHz_Tnom	Pass	2.40	7.35	9.75	20.00
2402MHz_Tmin	Pass	2.40	7.24	9.64	20.00
2402MHz_Tmax	Pass	2.40	7.59	9.99	20.00
2440MHz_Tnom	Pass	2.40	5.22	7.62	20.00
2440MHz_Tmin	Pass	2.40	5.11	7.51	20.00
2440MHz_Tmax	Pass	2.40	5.46	7.86	20.00
2480MHz_Tnom	Pass	2.40	5.88	8.28	20.00
2480MHz_Tmin	Pass	2.40	5.90	8.30	20.00
2480MHz_Tmax	Pass	2.40	6.02	8.42	20.00
BT-LE(500kbps)	-	-	-	-	-
2402MHz_Tnom	Pass	2.40	7.39	9.79	20.00
2402MHz_Tmin	Pass	2.40	7.34	9.74	20.00
2402MHz_Tmax	Pass	2.40	7.42	9.82	20.00
2440MHz_Tnom	Pass	2.40	5.32	7.72	20.00
2440MHz_Tmin	Pass	2.40	5.28	7.68	20.00
2440MHz_Tmax	Pass	2.40	5.46	7.86	20.00
2480MHz_Tnom	Pass	2.40	5.95	8.35	20.00
2480MHz_Tmin	Pass	2.40	5.88	8.28	20.00
2480MHz_Tmax	Pass	2.40	5.98	8.38	20.00

Port X = Port X output power; Total Power = Total power measure all transmit ports simultaneously.



Summary

Mode	EIRP PD (dBm/MHz)
2.4-2.4835GHz	-
BT-LE(1Mbps)	8.91
BT-LE(2Mbps)	8.12
BT-LE(125kbps)	8.96
BT-LE(500kbps)	8.86

RBW=1MHz

Result

Mode	Result	Gain (dBi)	PD (dBm/MHz)	EIRP PD (dBm/MHz)	EIRP PD Limit (dBm/MHz)
BT-LE(1Mbps)	-	-	-	-	-
2402MHz_Tnom	Pass	2.40	6.51	8.91	10.00
2440MHz_Tnom	Pass	2.40	4.71	7.11	10.00
2480MHz_Tnom	Pass	2.40	5.10	7.50	10.00
BT-LE(2Mbps)	-	-	-	-	-
2402MHz_Tnom	Pass	2.40	5.72	8.12	10.00
2440MHz_Tnom	Pass	2.40	3.77	6.17	10.00
2480MHz_Tnom	Pass	2.40	4.34	6.74	10.00
BT-LE(125kbps)	-	-	-	-	-
2402MHz_Tnom	Pass	2.40	6.56	8.96	10.00
2440MHz_Tnom	Pass	2.40	5.08	7.48	10.00
2480MHz_Tnom	Pass	2.40	5.12	7.52	10.00
BT-LE(500kbps)	-	-	-	-	-
2402MHz_Tnom	Pass	2.40	6.46	8.86	10.00
2440MHz_Tnom	Pass	2.40	4.91	7.31	10.00
2480MHz_Tnom	Pass	2.40	5.01	7.41	10.00

RBW=1MHz;  
Port X = Port X power density;



Summary

Mode	OBW (Hz)	ITU-Code
2.4-2.4835GHz	-	-
BT-LE(1Mbps)	1.031M	1M03F1D
BT-LE(2Mbps)	2.045M	2M05F1D
BT-LE(125kbps)	1.028M	1M03F1D
BT-LE(500kbps)	1.017M	1M02F1D

OBW = 99% occupied bandwidth

Result

Mode	Result	Limit (Hz)	fl-OBW (Hz)	fh-OBW (Hz)	OBW (Hz)
BT-LE(1Mbps)	-	-	-	-	-
2402MHz_Tnom	Pass	2.4-2.4835G	2.401473G	2.402503G	1.029M
2480MHz_Tnom	Pass	2.4-2.4835G	2.479471G	2.480503G	1.031M
BT-LE(2Mbps)	-	-	-	-	-
2402MHz_Tnom	Pass	2.4-2.4835G	2.400965G	2.403009G	2.045M
2480MHz_Tnom	Pass	2.4-2.4835G	2.478963G	2.481007G	2.045M
BT-LE(125kbps)	-	-	-	-	-
2402MHz_Tnom	Pass	2.4-2.4835G	2.401473G	2.402502G	1.028M
2480MHz_Tnom	Pass	2.4-2.4835G	2.479474G	2.4805G	1.025M
BT-LE(500kbps)	-	-	-	-	-
2402MHz_Tnom	Pass	2.4-2.4835G	2.40148G	2.402496G	1.015M
2480MHz_Tnom	Pass	2.4-2.4835G	2.479478G	2.480496G	1.017M

fl-OBW = fl lower edge 99% occupied bandwidth; fh-OBW = fh higher edge 99% occupied bandwidth; OBW = 99% occupied bandwidth; N dB = 6dB down bandwidth

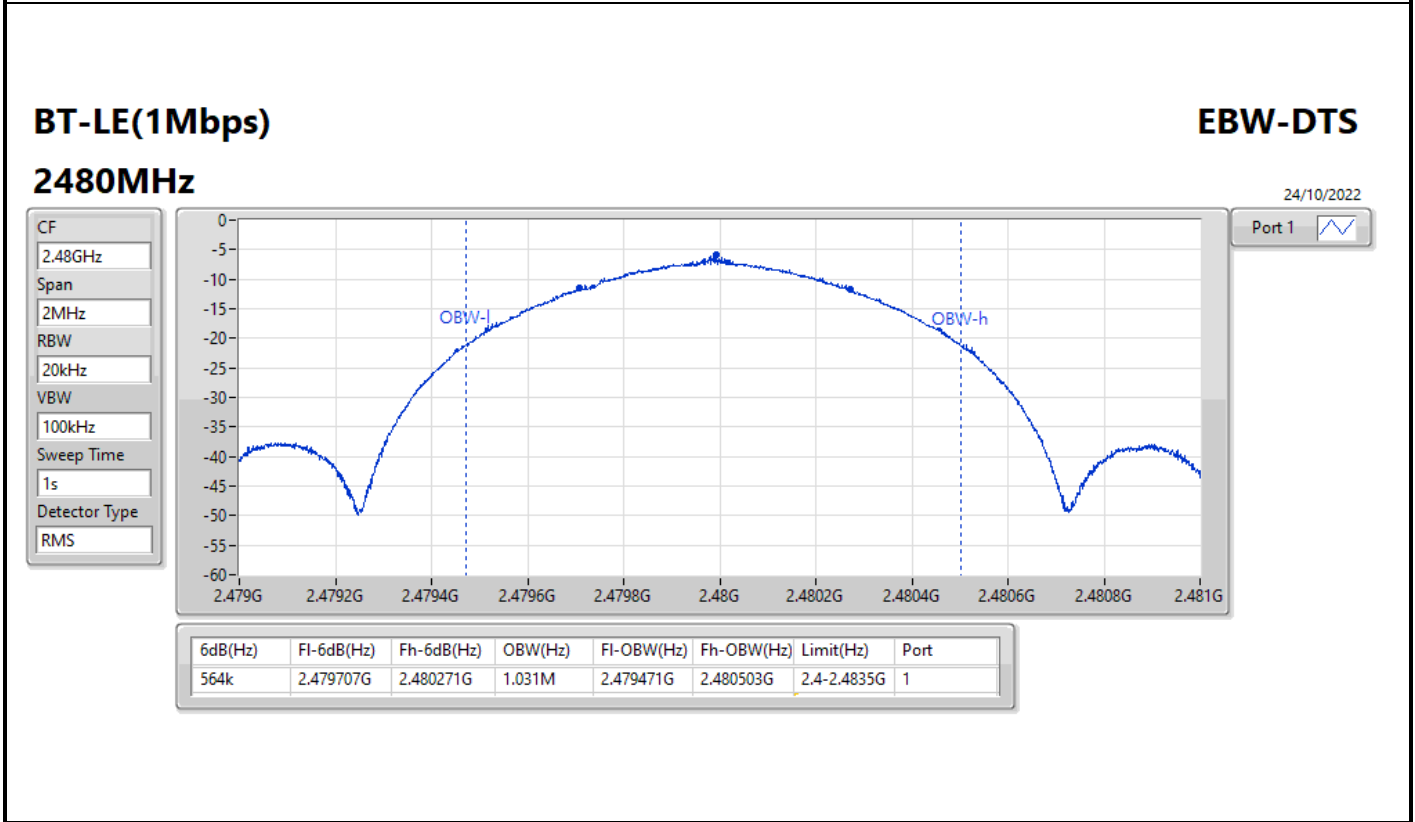
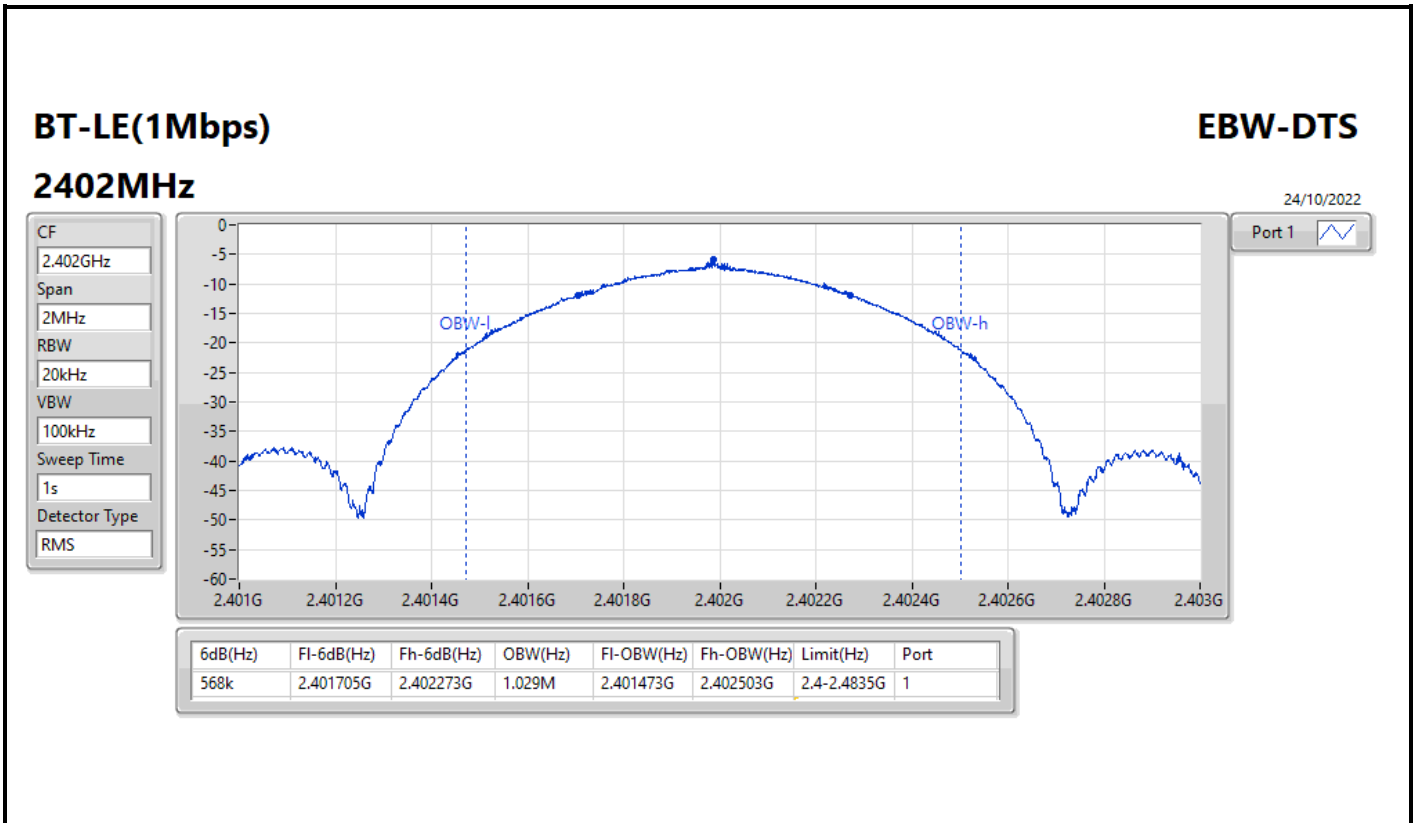

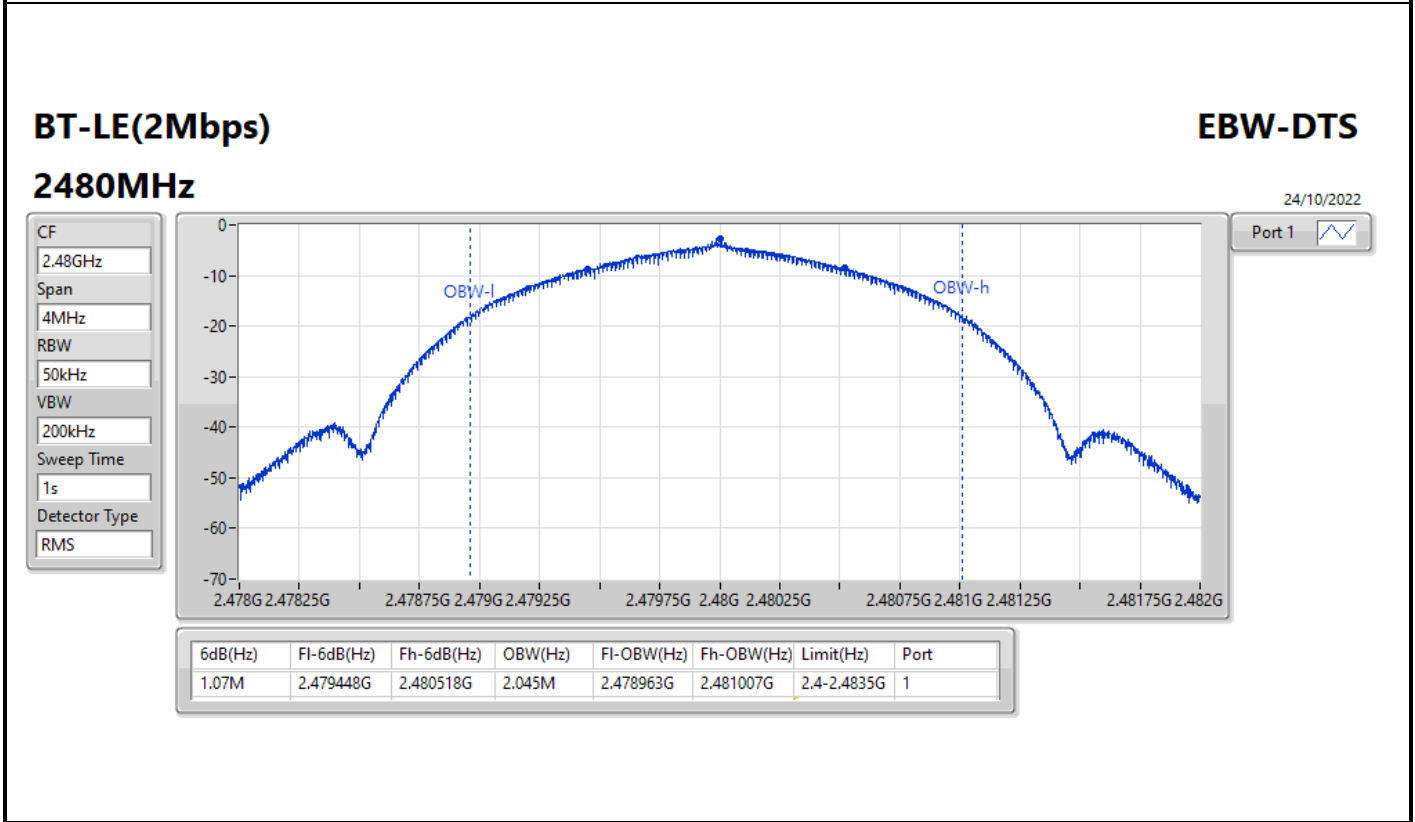
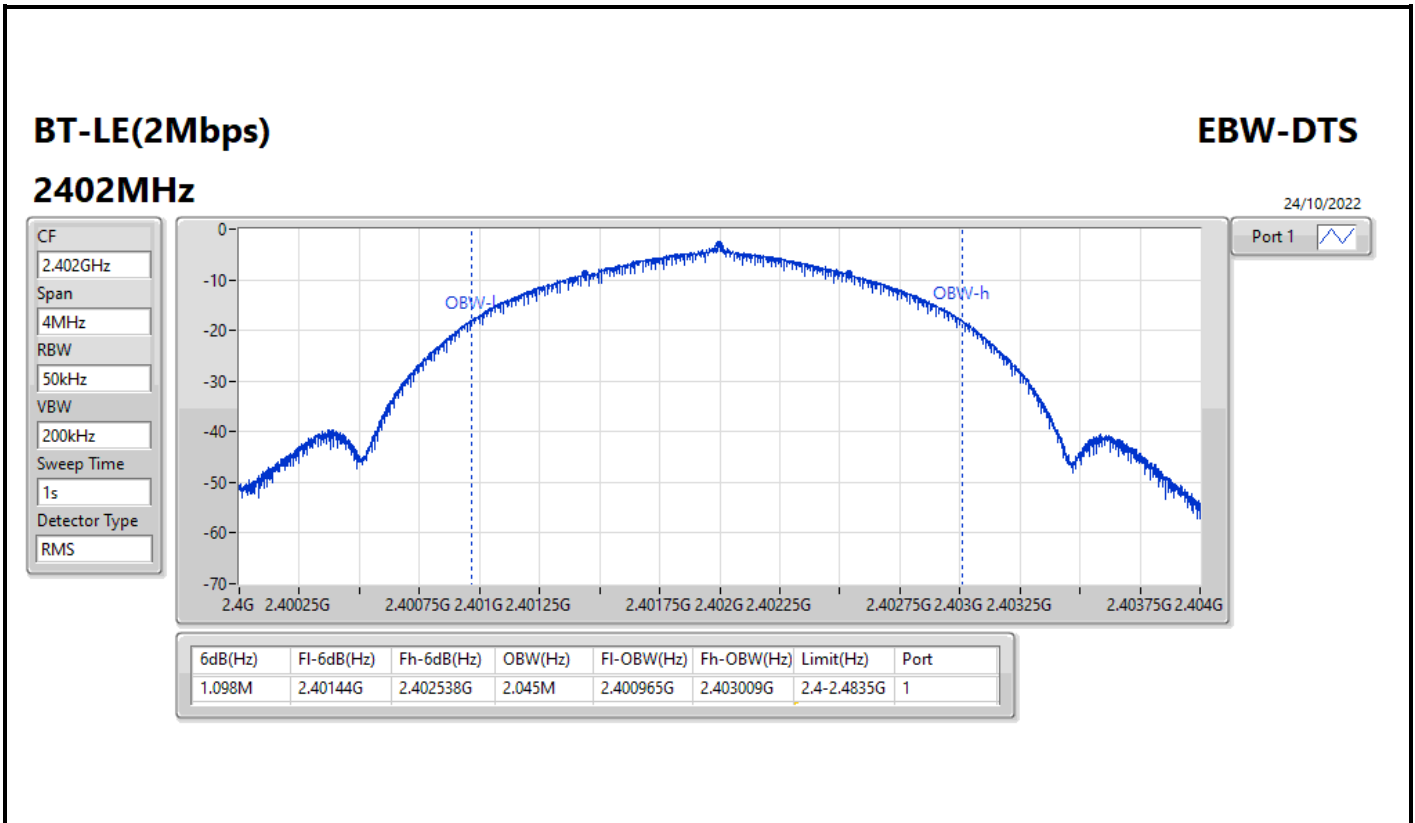

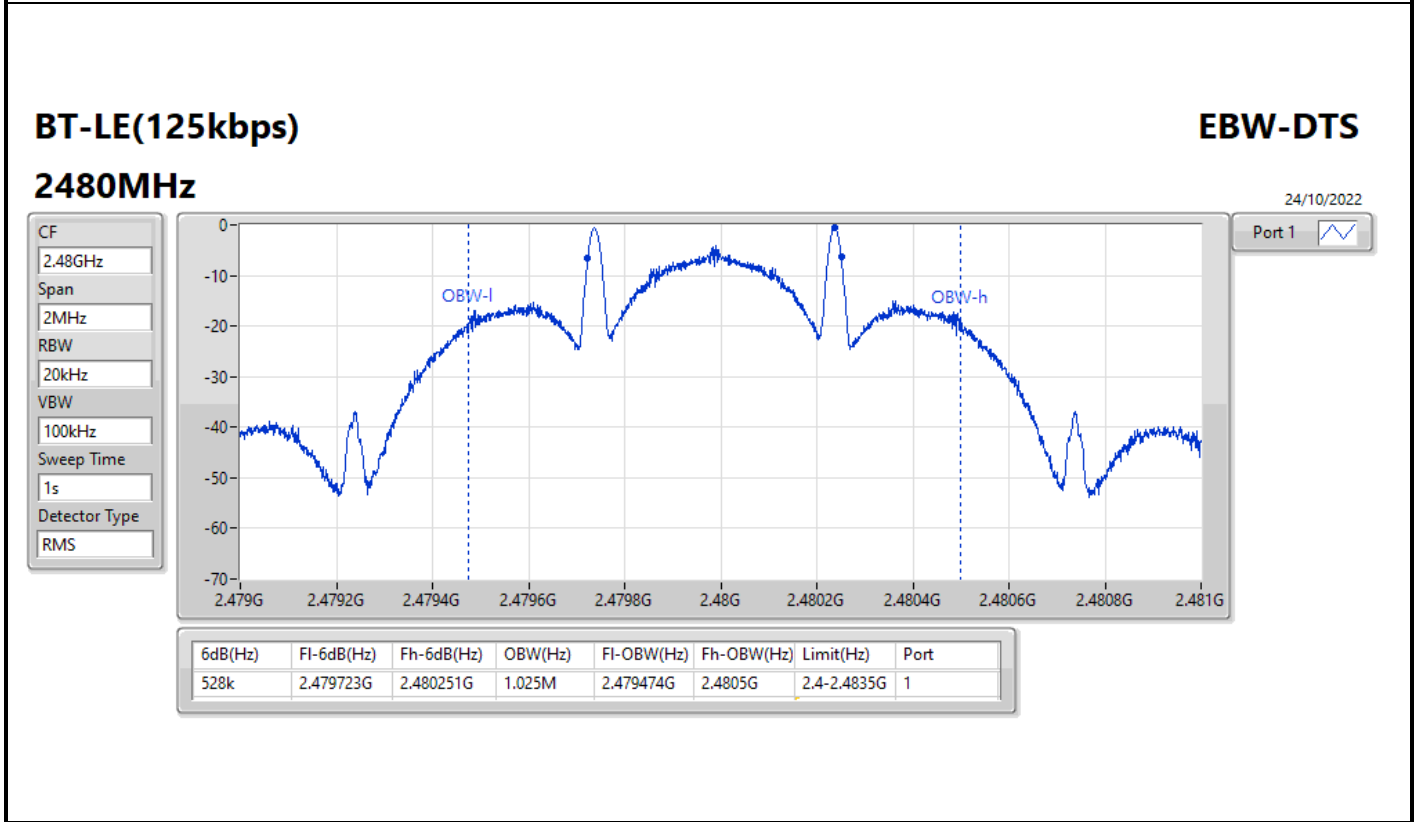
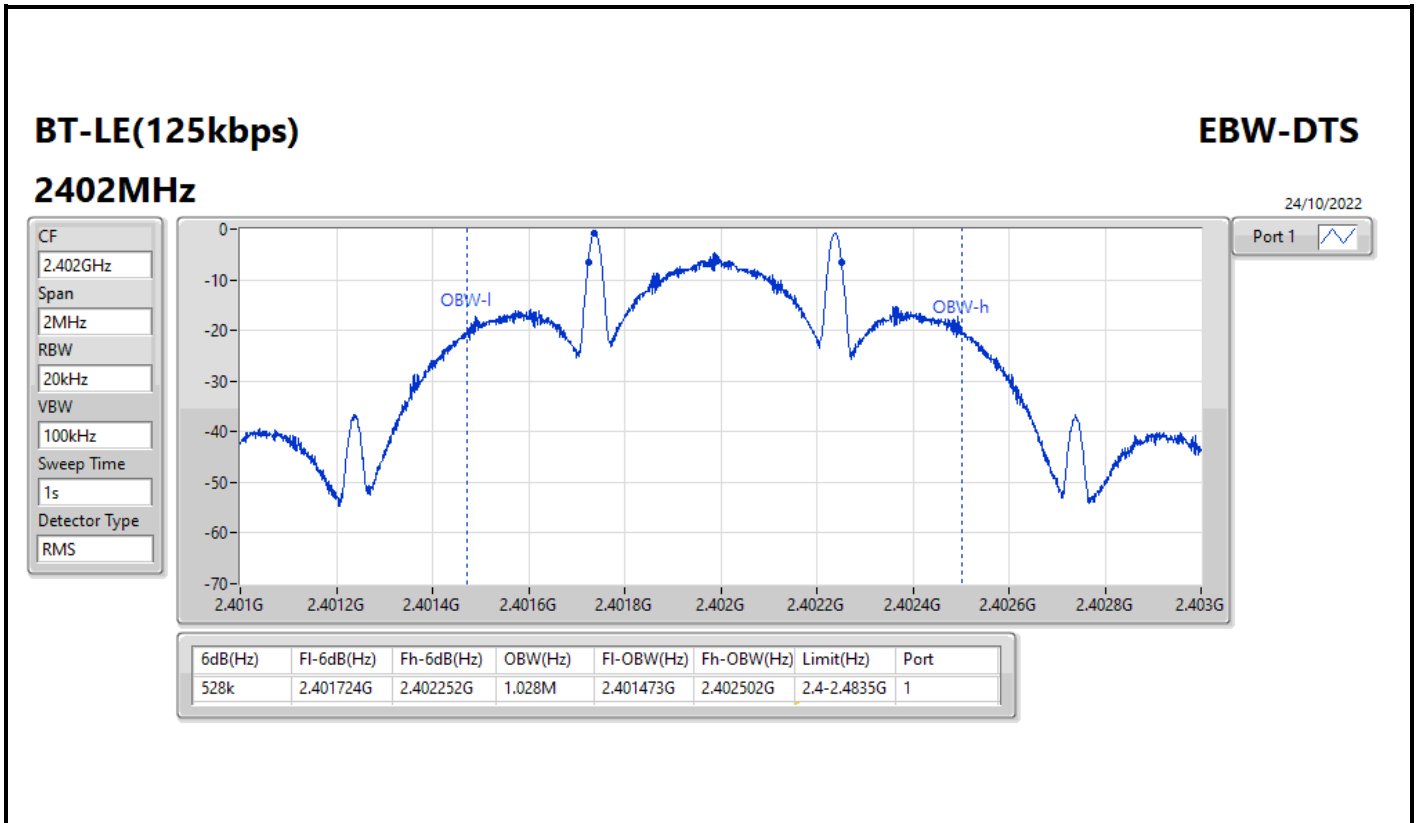

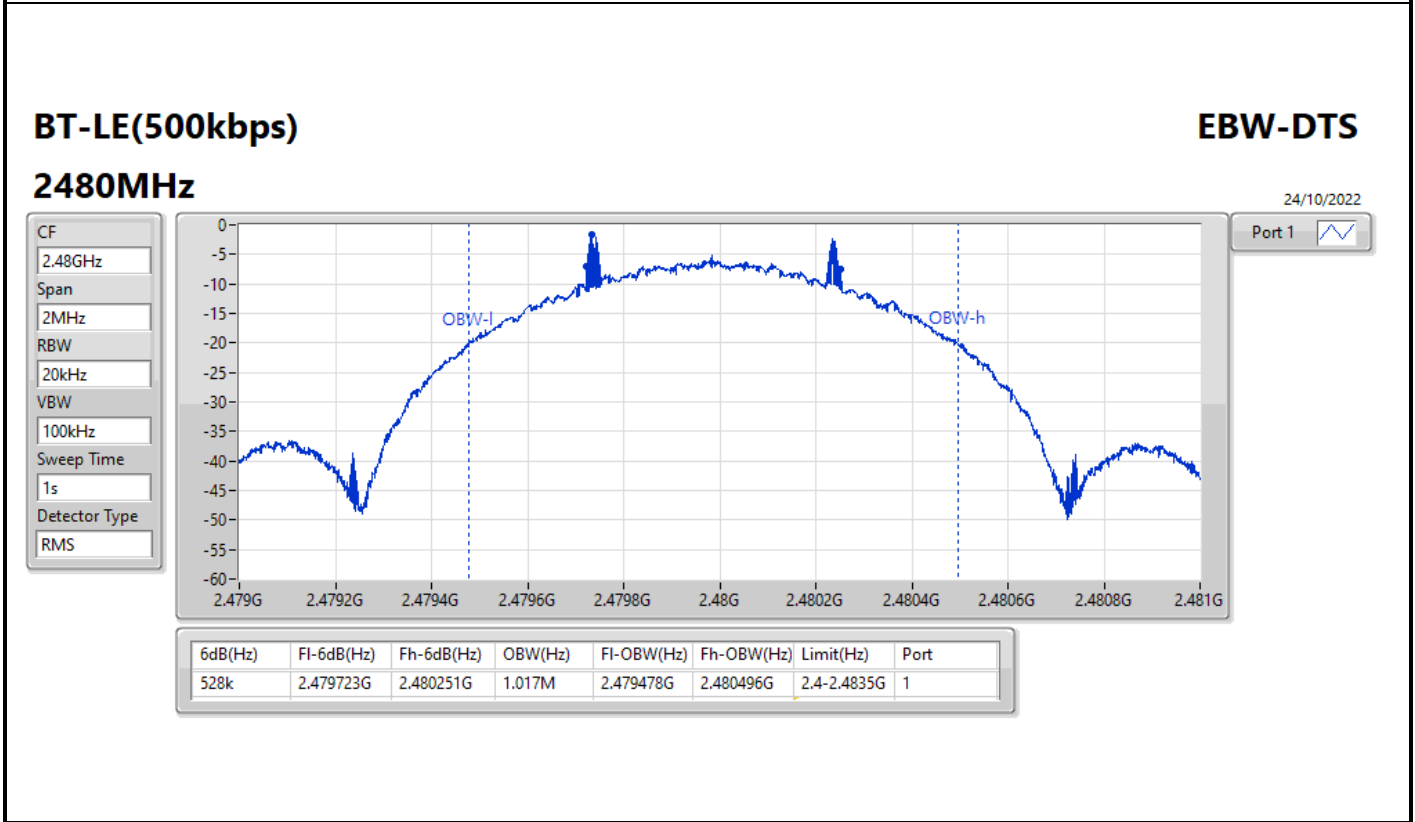
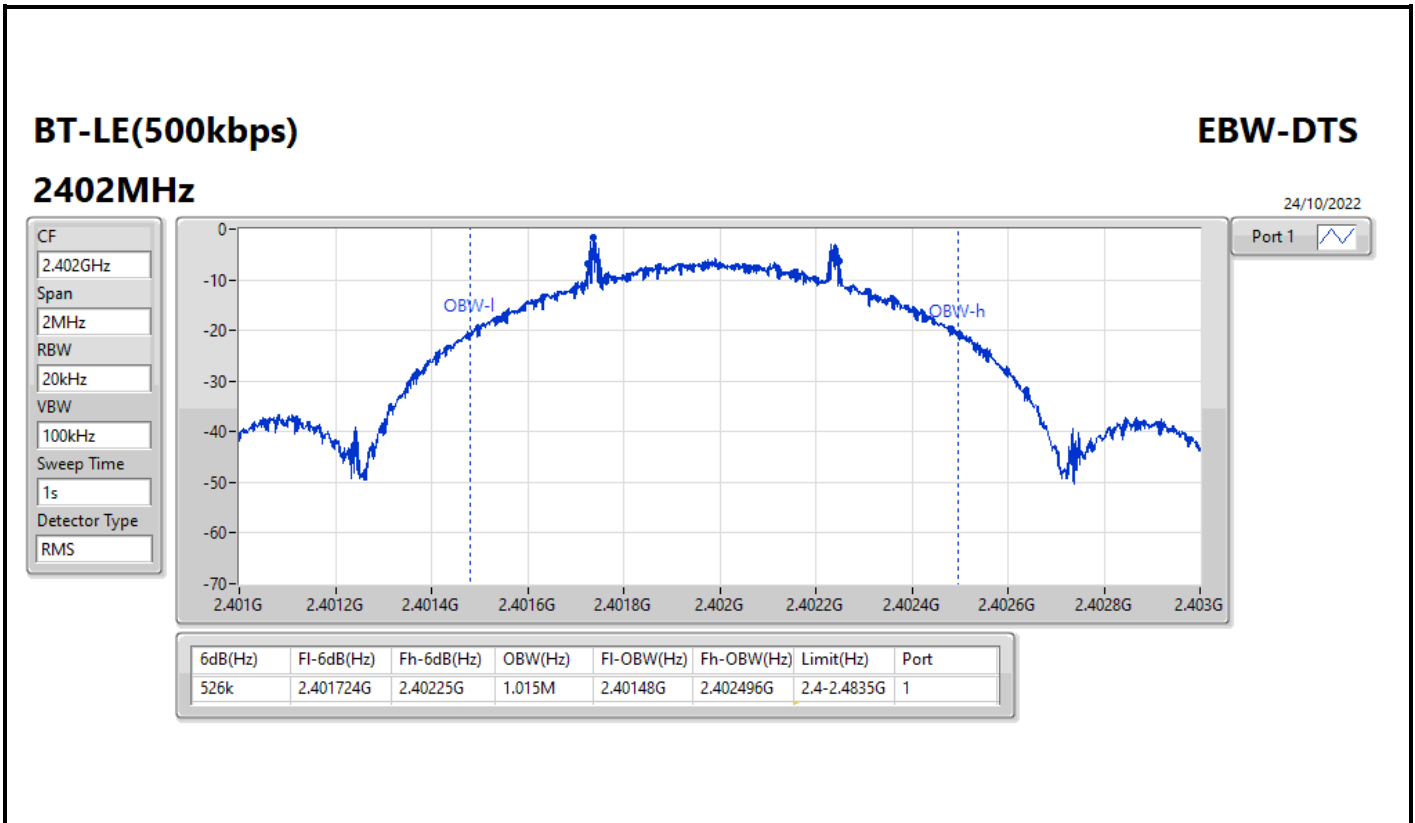



Summary

Mode	EIRP-A (dBm)	Limit-A (dBm)	EIRP-B (dBm)	Limit-B (dBm)
2.4-2.4835GHz	-	-	-	-
BT-LE(1Mbps)	-49.61	-10	-51.33	-20
BT-LE(2Mbps)	-44.42	-10	-49.93	-20
BT-LE(125kbps)	-45.97	-10	-46.44	-20
BT-LE(500kbps)	-49.78	-10	-51.42	-20

Result

Mode	Result	Freq (Hz)	EIRP (dBm)	Limit (dBm)	Freq (Hz)	EIRP (dBm)	Limit (dBm)
BT-LE(1Mbps)	-	-	-	-	-	-	-
2402MHz_Tnom	Pass	2.398471G	-51.33	-20	2.3995G	-49.61	-10
2402MHz_Tnom	Pass	2.485058G	-52.31	-20	2.484029G	-51.87	-10
2480MHz_Tnom	Pass	2.398469G	-52.69	-20	2.3995G	-51.43	-10
2480MHz_Tnom	Pass	2.485031G	-51.45	-20	2.484G	-50.88	-10
BT-LE(2Mbps)	-	-	-	-	-	-	-
2402MHz_Tnom	Pass	2.39641G	-49.99	-20	2.3995G	-44.42	-10
2402MHz_Tnom	Pass	2.487045G	-50.26	-20	2.485G	-50.24	-10
2480MHz_Tnom	Pass	2.397455G	-50.73	-20	2.3995G	-49.56	-10
2480MHz_Tnom	Pass	2.48709G	-49.93	-20	2.485G	-48.98	-10
BT-LE(125kbps)	-	-	-	-	-	-	-
2402MHz_Tnom	Pass	2.398444G	-46.86	-20	2.3995G	-46.29	-10
2402MHz_Tnom	Pass	2.485028G	-46.68	-20	2.484028G	-46.48	-10
2480MHz_Tnom	Pass	2.39845G	-46.97	-20	2.3995G	-47.01	-10
2480MHz_Tnom	Pass	2.485025G	-46.44	-20	2.484025G	-45.97	-10
BT-LE(500kbps)	-	-	-	-	-	-	-
2402MHz_Tnom	Pass	2.39847G	-51.42	-20	2.3995G	-49.78	-10
2402MHz_Tnom	Pass	2.485015G	-52.42	-20	2.484015G	-52.59	-10
2480MHz_Tnom	Pass	2.398483G	-52.65	-20	2.3995G	-51.50	-10
2480MHz_Tnom	Pass	2.485017G	-51.53	-20	2.484G	-51.09	-10

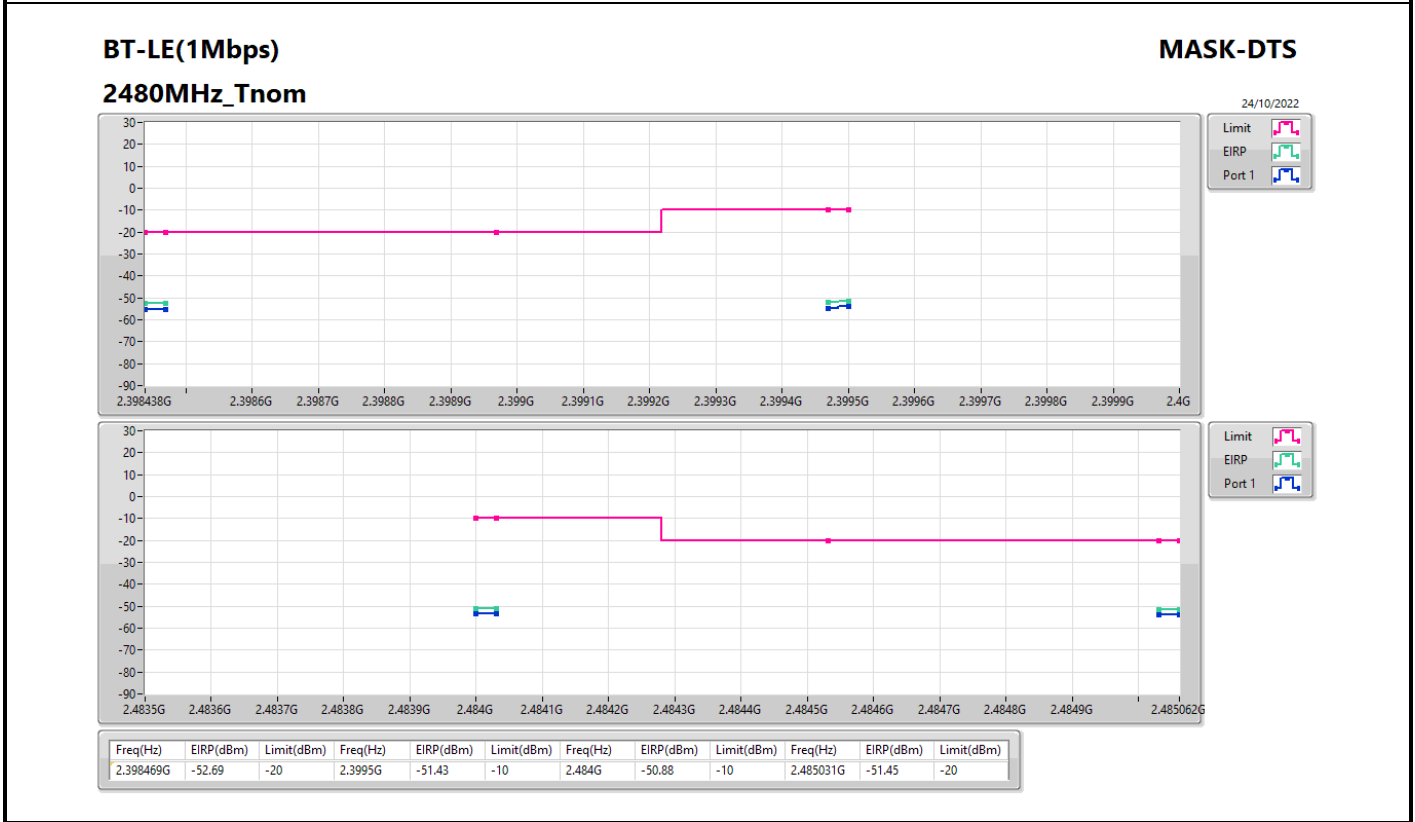
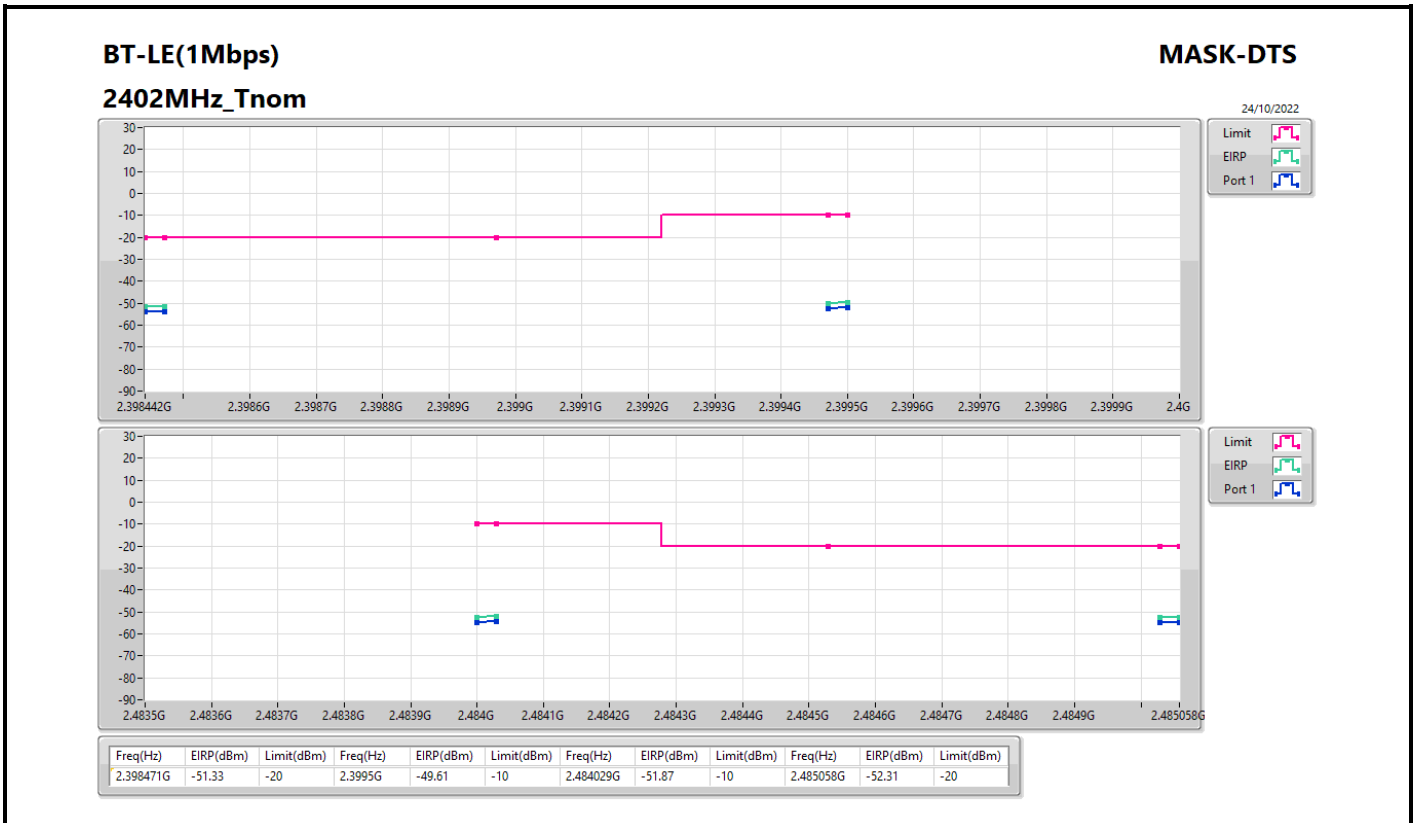

**BT-LE(2Mbps)**  
**2402MHz\_Tnom**

**MASK-DTS**

24/10/2022

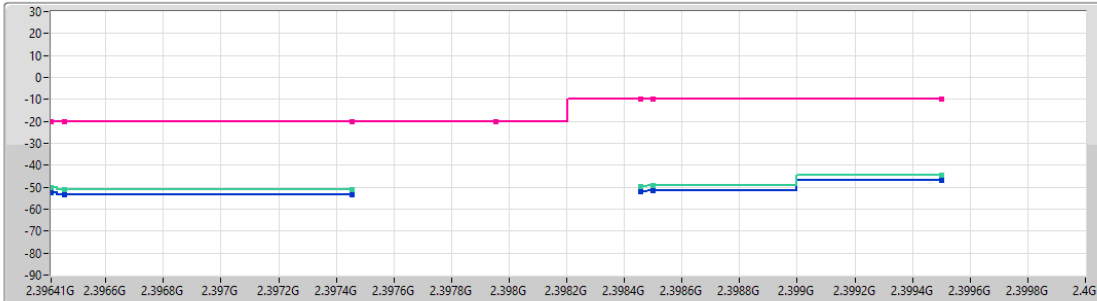

Limit

EIRP

Port 1

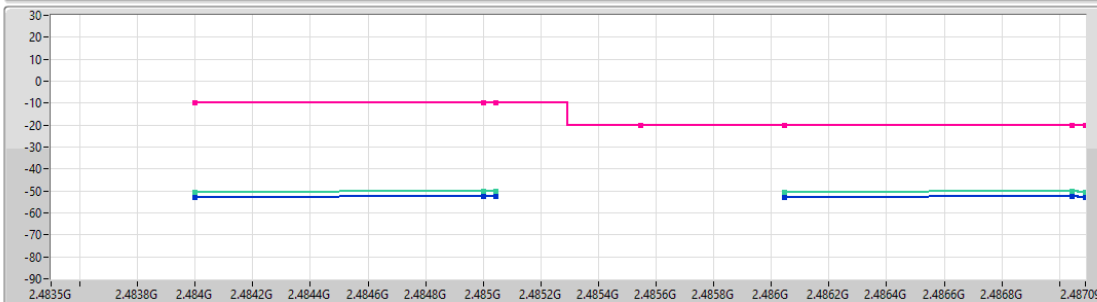

Limit

EIRP

Port 1

Freq(Hz)	EIRP(dBm)	Limit(dBm)	Freq(Hz)	EIRP(dBm)	Limit(dBm)	Freq(Hz)	EIRP(dBm)	Limit(dBm)	Freq(Hz)	EIRP(dBm)	Limit(dBm)
2.39641G	-49.99	-20	2.3995G	-44.42	-10	2.485G	-50.24	-10	2.487045G	-50.26	-20

**BT-LE(2Mbps)**  
**2480MHz\_Tnom**

**MASK-DTS**

24/10/2022

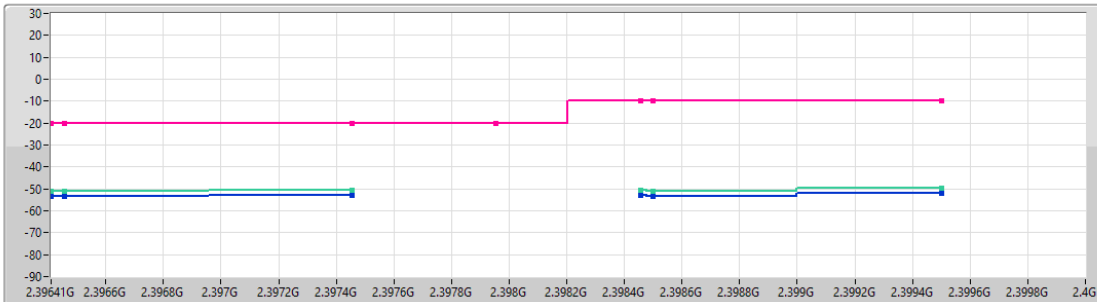

Limit

EIRP

Port 1

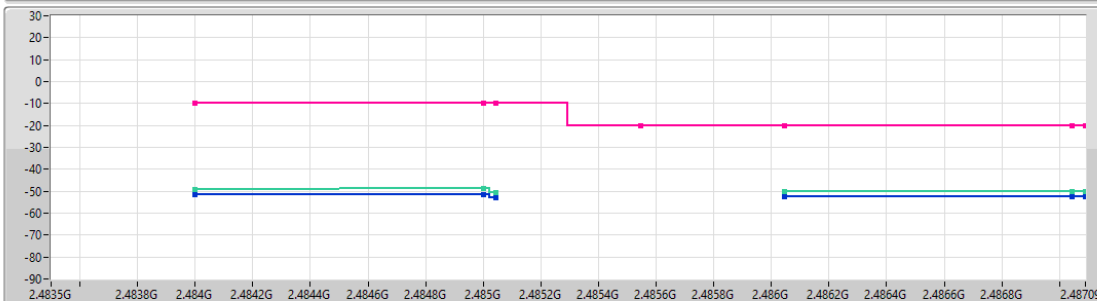

Limit

EIRP

Port 1

Freq(Hz)	EIRP(dBm)	Limit(dBm)	Freq(Hz)	EIRP(dBm)	Limit(dBm)	Freq(Hz)	EIRP(dBm)	Limit(dBm)	Freq(Hz)	EIRP(dBm)	Limit(dBm)
2.397455G	-50.73	-20	2.3995G	-49.56	-10	2.485G	-48.98	-10	2.48709G	-49.93	-20

**BT-LE(125kbps)**  
**2402MHz\_Tnom**

**MASK-DTS**

24/10/2022

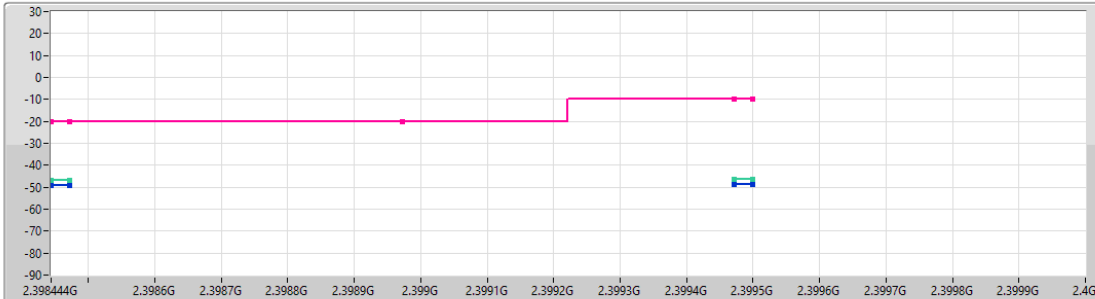

Limit

EIRP

Port 1

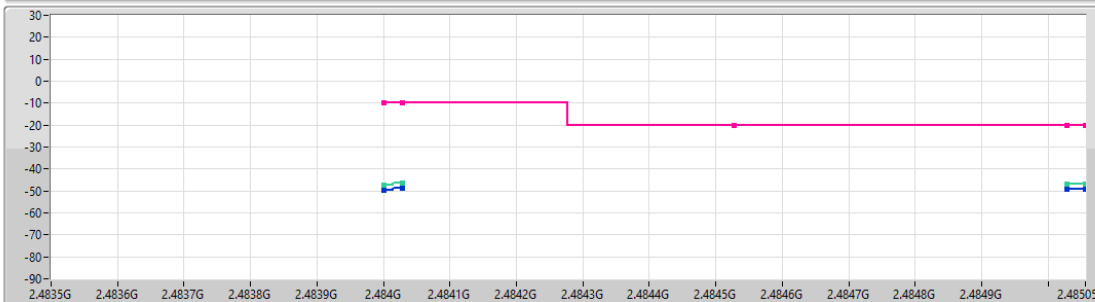

Limit

EIRP

Port 1

Freq(Hz)	EIRP(dBm)	Limit(dBm)	Freq(Hz)	EIRP(dBm)	Limit(dBm)	Freq(Hz)	EIRP(dBm)	Limit(dBm)	Freq(Hz)	EIRP(dBm)	Limit(dBm)
2.398444G	-46.86	-20	2.3995G	-46.29	-10	2.484028G	-46.48	-10	2.485028G	-46.68	-20

**BT-LE(125kbps)**  
**2480MHz\_Tnom**

**MASK-DTS**

24/10/2022

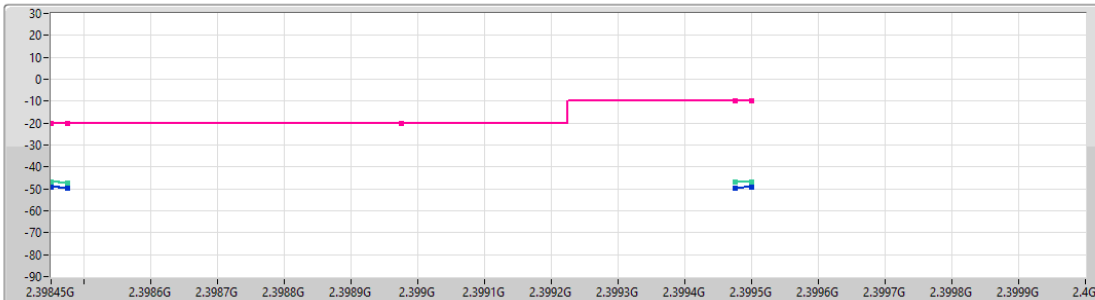

Limit

EIRP

Port 1

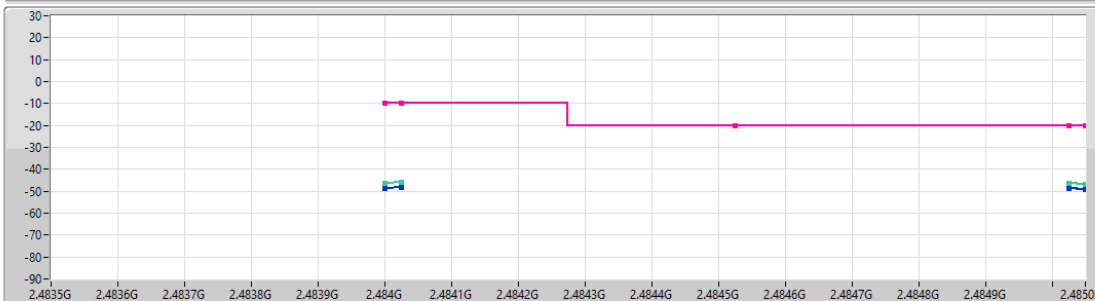

Limit

EIRP

Port 1

Freq(Hz)	EIRP(dBm)	Limit(dBm)	Freq(Hz)	EIRP(dBm)	Limit(dBm)	Freq(Hz)	EIRP(dBm)	Limit(dBm)	Freq(Hz)	EIRP(dBm)	Limit(dBm)
2.39845G	-46.97	-20	2.3995G	-47.01	-10	2.484025G	-45.97	-10	2.485025G	-46.44	-20

**BT-LE(500kbps)**  
**2402MHz\_Tnom**

**MASK-DTS**

24/10/2022

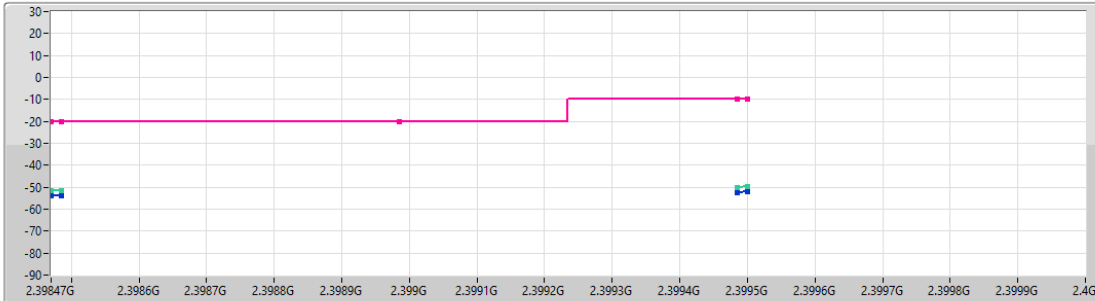

Limit

EIRP

Port 1

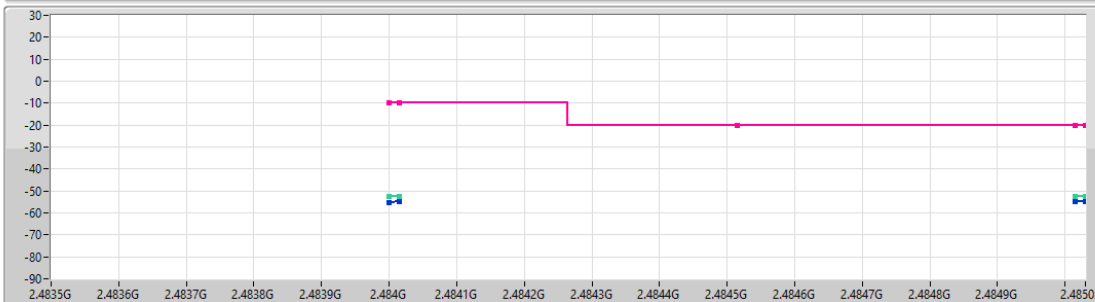

Limit

EIRP

Port 1

Freq(Hz)	EIRP(dBm)	Limit(dBm)	Freq(Hz)	EIRP(dBm)	Limit(dBm)	Freq(Hz)	EIRP(dBm)	Limit(dBm)	Freq(Hz)	EIRP(dBm)	Limit(dBm)
2.39847G	-51.42	-20	2.3995G	-49.78	-10	2.484015G	-52.59	-10	2.485015G	-52.42	-20

**BT-LE(500kbps)**  
**2480MHz\_Tnom**

**MASK-DTS**

24/10/2022

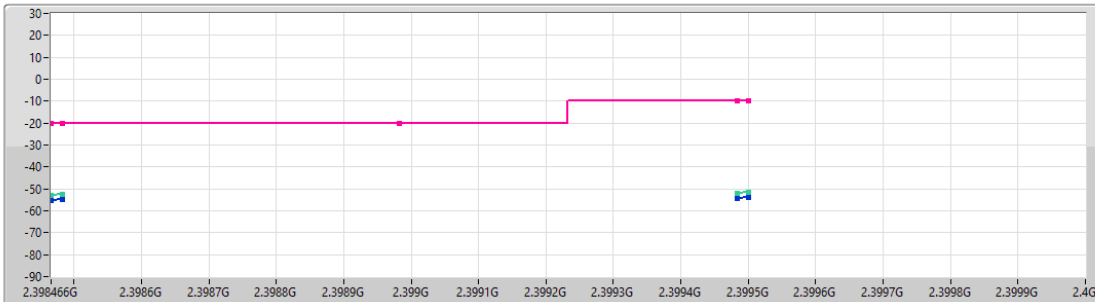

Limit

EIRP

Port 1

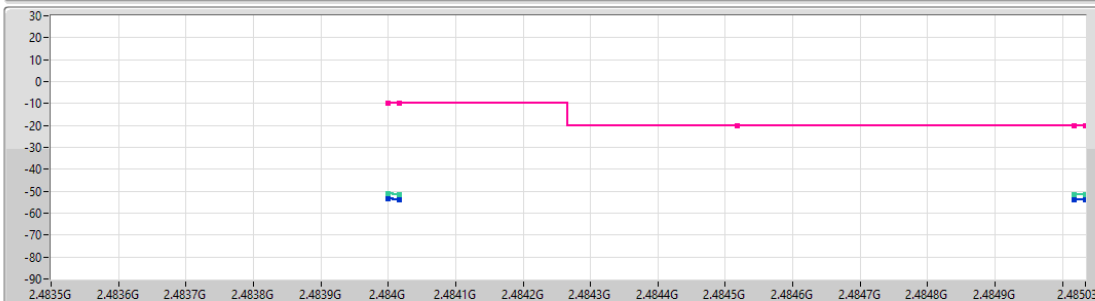

Limit

EIRP

Port 1

Freq(Hz)	EIRP(dBm)	Limit(dBm)	Freq(Hz)	EIRP(dBm)	Limit(dBm)	Freq(Hz)	EIRP(dBm)	Limit(dBm)	Freq(Hz)	EIRP(dBm)	Limit(dBm)
2.398483G	-52.65	-20	2.3995G	-51.50	-10	2.484G	-51.09	-10	2.485017G	-51.53	-20



Summary

Mode	Result	Type	Freq (Hz)	Level (dBm)	Limit (dBm)	Margin (dB)	Factor (dB)	Dist (m)	Condition	Azimuth (°)	Height (m)	Comments
2.4-2.4835GHz	-	-	-	-	-	-	-	-	-	-	-	-
BT-LE(2Mbps)	Pass	AV	528.03M	-61.76	-54.00	-7.76	7.75	3	Horizontal	360	1.5	-

Result

Mode	Result	Type	Freq (Hz)	Level (dBm)	Limit (dBm)	Margin (dB)	Factor (dB)	Dist (m)	Condition	Azimuth (°)	Height (m)	Comments
BT-LE(2Mbps)	-	-	-	-	-	-	-	-	-	-	-	-
2480MHz_TX	Pass	AV	240.01M	-71.99	-36.00	-35.99	0.32	3	Vertical	0	1.5	-
2480MHz_TX	Pass	AV	432.02M	-66.38	-36.00	-30.38	5.09	3	Vertical	0	1.5	-
2480MHz_TX	Pass	AV	528.03M	-68.39	-54.00	-14.39	6.73	3	Vertical	0	1.5	-
2480MHz_TX	Pass	AV	240.01M	-66.51	-36.00	-30.51	1.16	3	Horizontal	360	1.5	-
2480MHz_TX	Pass	AV	432.02M	-62.22	-36.00	-26.22	5.76	3	Horizontal	360	1.5	-
2480MHz_TX	Pass	AV	528.03M	-61.76	-54.00	-7.76	7.75	3	Horizontal	360	1.5	-

**BT-LE(2Mbps)**  
**2480MHz\_TX**

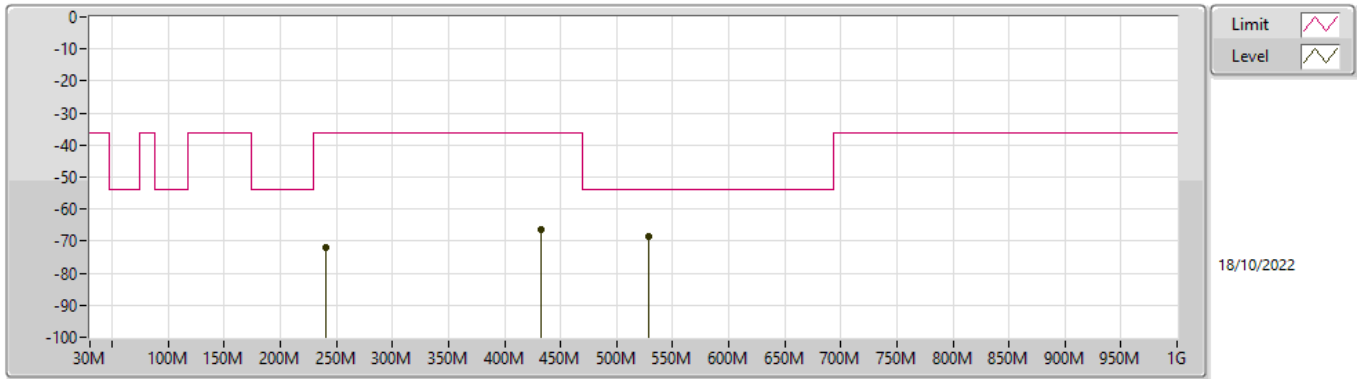

Type	Freq (Hz)	Level (dBm)	Limit (dBm)	Margin (dB)	Factor (dB)	Dist (m)	Condition	Azimuth (°)	Height (m)	Comment	Raw (dBm)
AV	240.01M	-71.99	-36.00	-35.99	0.32	3	Vertical	0	1.5	-	-72.31
AV	432.02M	-66.38	-36.00	-30.38	5.09	3	Vertical	0	1.5	-	-71.47
AV	528.03M	-68.39	-54.00	-14.39	6.73	3	Vertical	0	1.5	-	-75.12

**BT-LE(2Mbps)**  
**2480MHz\_TX**

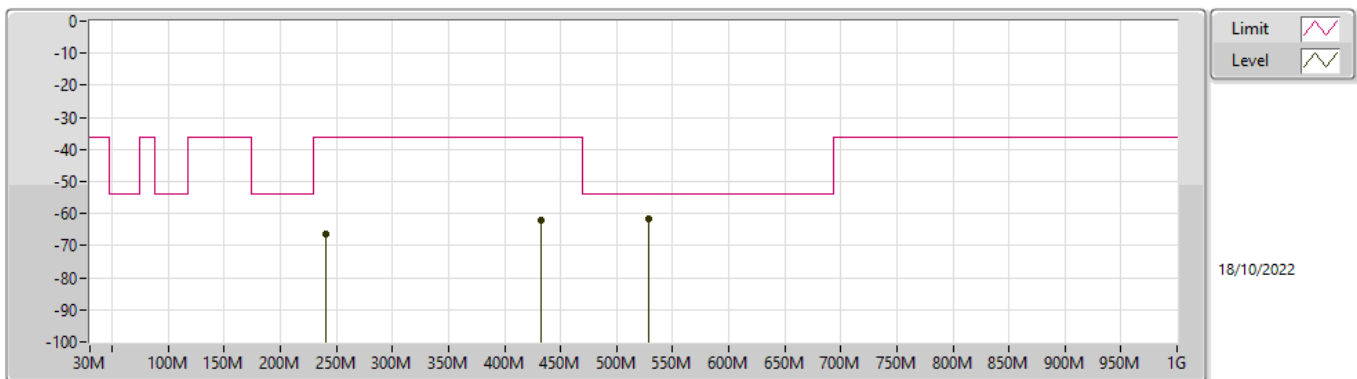

Type	Freq (Hz)	Level (dBm)	Limit (dBm)	Margin (dB)	Factor (dB)	Dist (m)	Condition	Azimuth (°)	Height (m)	Comment	Raw (dBm)
AV	240.01M	-66.51	-36.00	-30.51	1.16	3	Horizontal	360	1.5	-	-67.67
AV	432.02M	-62.22	-36.00	-26.22	5.76	3	Horizontal	360	1.5	-	-67.98
AV	528.03M	-61.76	-54.00	-7.76	7.75	3	Horizontal	360	1.5	-	-69.51



Summary

Mode	Result	Type	Freq (Hz)	Level (dBm)	Limit (dBm)	Margin (dB)	Factor (dB)	Dist (m)	Condition	Azimuth (°)	Height (m)	Comments
2.4-2.4835GHz	-	-	-	-	-	-	-	-	-	-	-	-
BT-LE(1Mbps)	Pass	AV	4.95963G	-39.42	-30.00	-9.42	2.92	3	Horizontal	360	1.5	-
BT-LE(2Mbps)	Pass	AV	9.91989G	-40.11	-30.00	-10.11	3.66	3	Vertical	0	1.5	-
BT-LE(125kbps)	Pass	AV	4.95963G	-40.13	-30.00	-10.13	2.92	3	Horizontal	360	1.5	-
BT-LE(500kbps)	Pass	AV	4.95921G	-39.50	-30.00	-9.50	2.92	3	Horizontal	360	1.5	-

Result

Mode	Result	Type	Freq (Hz)	Level (dBm)	Limit (dBm)	Margin (dB)	Factor (dB)	Dist (m)	Condition	Azimuth (°)	Height (m)	Comments
BT-LE(1Mbps)	-	-	-	-	-	-	-	-	-	-	-	-
2402MHz_TX	Pass	AV	4.80445G	-46.47	-30.00	-16.47	3.10	3	Vertical	360	1.5	-
2402MHz_TX	Pass	AV	7.20679G	-50.11	-30.00	-20.11	3.13	3	Vertical	360	1.5	-
2402MHz_TX	Pass	AV	9.60705G	-48.84	-30.00	-18.84	3.56	3	Vertical	360	1.5	-
2402MHz_TX	Pass	AV	4.80362G	-46.06	-30.00	-16.06	3.10	3	Horizontal	0	1.5	-
2402MHz_TX	Pass	AV	7.20679G	-53.80	-30.00	-23.80	3.13	3	Horizontal	0	1.5	-
2402MHz_TX	Pass	AV	9.60705G	-50.67	-30.00	-20.67	3.56	3	Horizontal	0	1.5	-
2480MHz_TX	Pass	AV	4.95963G	-42.37	-30.00	-12.37	2.92	3	Vertical	0	1.5	-
2480MHz_TX	Pass	AV	7.4408G	-51.91	-30.00	-21.91	2.87	3	Vertical	0	1.5	-
2480MHz_TX	Pass	AV	9.91906G	-42.89	-30.00	-12.89	3.66	3	Vertical	0	1.5	-
2480MHz_TX	Pass	AV	4.95963G	-39.42	-30.00	-9.42	2.92	3	Horizontal	360	1.5	-
2480MHz_TX	Pass	AV	7.43914G	-50.86	-30.00	-20.86	2.87	3	Horizontal	360	1.5	-
2480MHz_TX	Pass	AV	9.91989G	-46.01	-30.00	-16.01	3.66	3	Horizontal	360	1.5	-
BT-LE(2Mbps)	-	-	-	-	-	-	-	-	-	-	-	-
2402MHz_TX	Pass	AV	4.80486G	-46.82	-30.00	-16.82	3.10	3	Vertical	360	1.5	-
2402MHz_TX	Pass	AV	7.2072G	-50.78	-30.00	-20.78	3.13	3	Vertical	360	1.5	-
2402MHz_TX	Pass	AV	9.60995G	-49.07	-30.00	-19.07	3.56	3	Vertical	360	1.5	-
2402MHz_TX	Pass	AV	4.80486G	-47.20	-30.00	-17.20	3.10	3	Horizontal	0	1.5	-
2402MHz_TX	Pass	AV	7.20596G	-53.05	-30.00	-23.05	3.13	3	Horizontal	0	1.5	-
2402MHz_TX	Pass	AV	9.60829G	-50.65	-30.00	-20.65	3.56	3	Horizontal	0	1.5	-
2480MHz_TX	Pass	AV	4.96004G	-43.07	-30.00	-13.07	2.92	3	Vertical	0	1.5	-
2480MHz_TX	Pass	AV	7.43831G	-51.39	-30.00	-21.39	2.87	3	Vertical	0	1.5	-
2480MHz_TX	Pass	AV	9.91989G	-40.11	-30.00	-10.11	3.66	3	Vertical	0	1.5	-
2480MHz_TX	Pass	AV	4.9588G	-40.69	-30.00	-10.69	2.92	3	Horizontal	360	1.5	-
2480MHz_TX	Pass	AV	7.43872G	-52.52	-30.00	-22.52	2.87	3	Horizontal	360	1.5	-
2480MHz_TX	Pass	AV	9.91989G	-46.61	-30.00	-16.61	3.66	3	Horizontal	360	1.5	-
BT-LE(125kbps)	-	-	-	-	-	-	-	-	-	-	-	-
2402MHz_TX	Pass	AV	4.80403G	-46.46	-30.00	-16.46	3.10	3	Vertical	360	1.5	-
2402MHz_TX	Pass	AV	7.20554G	-51.35	-30.00	-21.35	3.13	3	Vertical	360	1.5	-
2402MHz_TX	Pass	AV	9.60705G	-49.04	-30.00	-19.04	3.56	3	Vertical	360	1.5	-
2402MHz_TX	Pass	AV	4.80403G	-46.83	-30.00	-16.83	3.10	3	Horizontal	0	1.5	-
2402MHz_TX	Pass	AV	7.20637G	-54.13	-30.00	-24.13	3.13	3	Horizontal	0	1.5	-
2402MHz_TX	Pass	AV	9.60871G	-51.34	-30.00	-21.34	3.56	3	Horizontal	0	1.5	-
2480MHz_TX	Pass	AV	4.96046G	-42.80	-30.00	-12.80	2.92	3	Vertical	0	1.5	-
2480MHz_TX	Pass	AV	7.43955G	-51.67	-30.00	-21.67	2.87	3	Vertical	0	1.5	-
2480MHz_TX	Pass	AV	9.92072G	-44.19	-30.00	-14.19	3.66	3	Vertical	0	1.5	-
2480MHz_TX	Pass	AV	4.95963G	-40.13	-30.00	-10.13	2.92	3	Horizontal	360	1.5	-
2480MHz_TX	Pass	AV	7.4408G	-52.81	-30.00	-22.81	2.87	3	Horizontal	360	1.5	-
2480MHz_TX	Pass	AV	9.92072G	-46.83	-30.00	-16.83	3.66	3	Horizontal	360	1.5	-
BT-LE(500kbps)	-	-	-	-	-	-	-	-	-	-	-	-
2402MHz_TX	Pass	AV	4.80403G	-46.95	-30.00	-16.95	3.10	3	Vertical	360	1.5	-
2402MHz_TX	Pass	AV	7.20513G	-51.07	-30.00	-21.07	3.13	3	Vertical	360	1.5	-
2402MHz_TX	Pass	AV	9.60705G	-48.93	-30.00	-18.93	3.56	3	Vertical	360	1.5	-
2402MHz_TX	Pass	AV	4.80403G	-46.21	-30.00	-16.21	3.10	3	Horizontal	0	1.5	-
2402MHz_TX	Pass	AV	7.20554G	-53.50	-30.00	-23.50	3.13	3	Horizontal	0	1.5	-
2402MHz_TX	Pass	AV	9.60871G	-51.53	-30.00	-21.53	3.56	3	Horizontal	0	1.5	-
2480MHz_TX	Pass	AV	4.96004G	-43.18	-30.00	-13.18	2.92	3	Vertical	0	1.5	-
2480MHz_TX	Pass	AV	7.43997G	-52.19	-30.00	-22.19	2.87	3	Vertical	0	1.5	-
2480MHz_TX	Pass	AV	9.92072G	-42.68	-30.00	-12.68	3.66	3	Vertical	0	1.5	-
2480MHz_TX	Pass	AV	4.95921G	-39.50	-30.00	-9.50	2.92	3	Horizontal	360	1.5	-
2480MHz_TX	Pass	AV	7.43914G	-51.61	-30.00	-21.61	2.87	3	Horizontal	360	1.5	-
2480MHz_TX	Pass	AV	9.91906G	-46.57	-30.00	-16.57	3.66	3	Horizontal	360	1.5	-

**BT-LE(1Mbps)**  
**2402MHz\_TX**

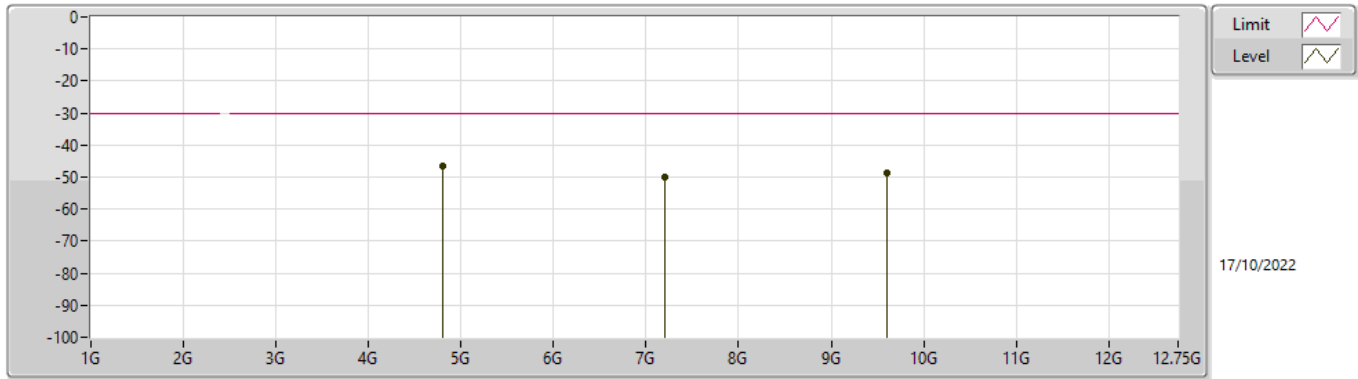

Freq (Hz)	Level (dBm)	Limit (dBm)	Margin (dB)	Factor (dB)	Condition	Raw (dBm)
4.80445G	-46.47	-30.00	-16.47	3.10	Vertical	-49.57
7.20679G	-50.11	-30.00	-20.11	3.13	Vertical	-53.24
9.60705G	-48.84	-30.00	-18.84	3.56	Vertical	-52.40

**BT-LE(1Mbps)**  
**2402MHz\_TX**

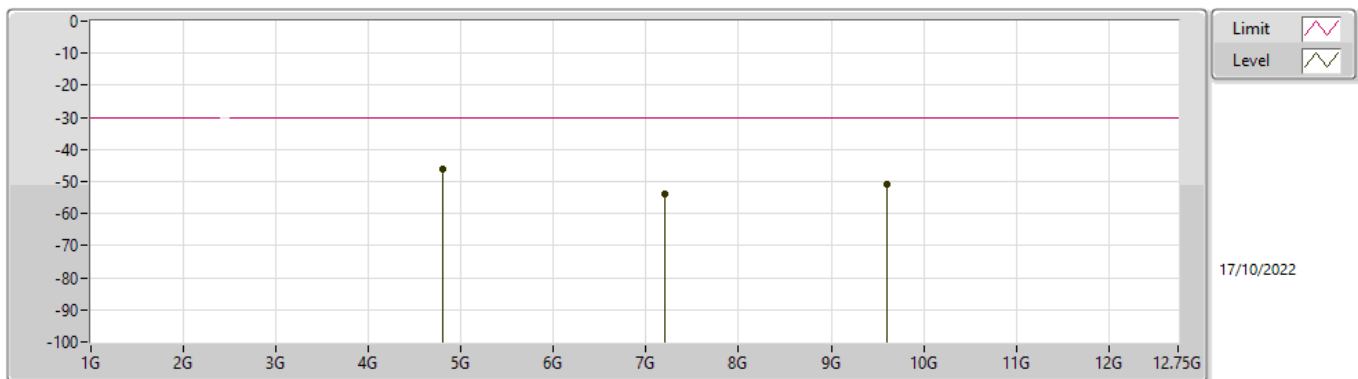

Freq (Hz)	Level (dBm)	Limit (dBm)	Margin (dB)	Factor (dB)	Condition	Raw (dBm)
4.80362G	-46.06	-30.00	-16.06	3.10	Horizontal	-49.16
7.20679G	-53.80	-30.00	-23.80	3.13	Horizontal	-56.93
9.60705G	-50.67	-30.00	-20.67	3.56	Horizontal	-54.23

**BT-LE(1Mbps)**  
**2480MHz\_TX**

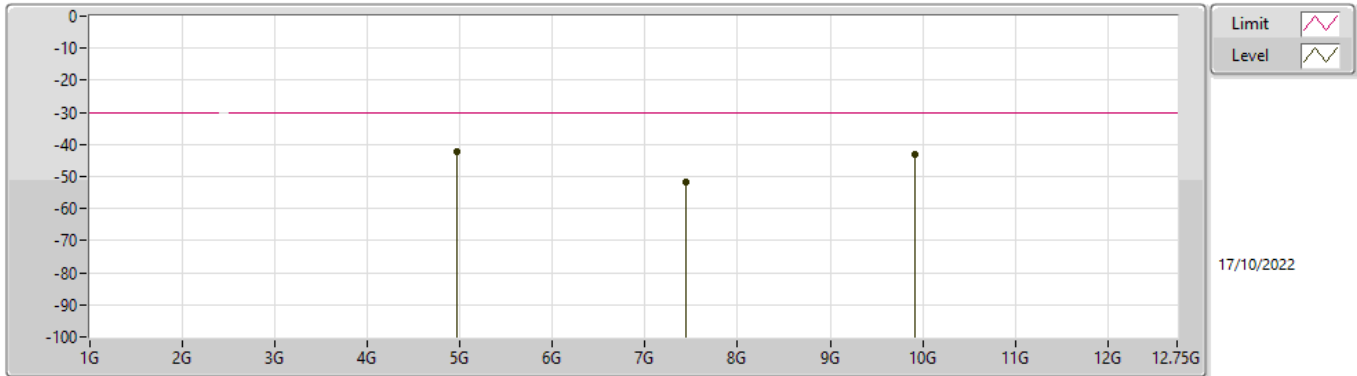

Freq (Hz)	Level (dBm)	Limit (dBm)	Margin (dB)	Factor (dB)	Condition	Raw (dBm)
4.95963G	-42.37	-30.00	-12.37	2.92	Vertical	-45.29
7.4408G	-51.91	-30.00	-21.91	2.87	Vertical	-54.78
9.91906G	-42.89	-30.00	-12.89	3.66	Vertical	-46.55

**BT-LE(1Mbps)**  
**2480MHz\_TX**

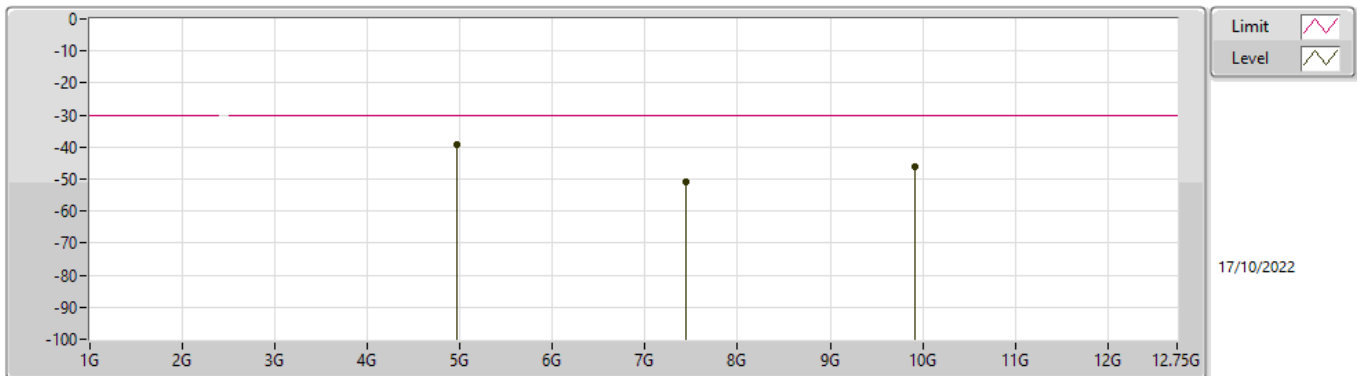

Freq (Hz)	Level (dBm)	Limit (dBm)	Margin (dB)	Factor (dB)	Condition	Raw (dBm)
4.95963G	-39.42	-30.00	-9.42	2.92	Horizontal	-42.34
7.43914G	-50.86	-30.00	-20.86	2.87	Horizontal	-53.73
9.91989G	-46.01	-30.00	-16.01	3.66	Horizontal	-49.67

**BT-LE(2Mbps)**  
**2402MHz\_TX**

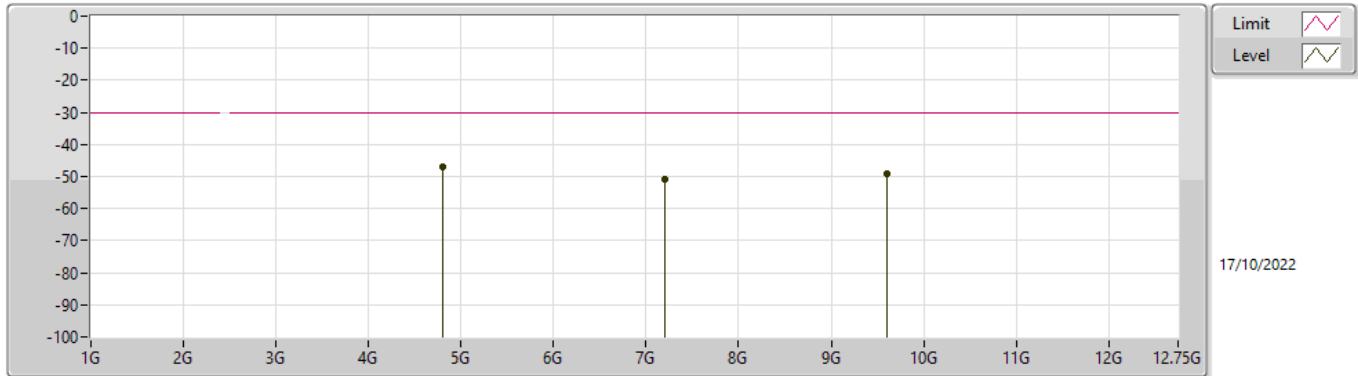

Freq (Hz)	Level (dBm)	Limit (dBm)	Margin (dB)	Factor (dB)	Condition	Raw (dBm)
4.80486G	-46.82	-30.00	-16.82	3.10	Vertical	-49.92
7.2072G	-50.78	-30.00	-20.78	3.13	Vertical	-53.91
9.60995G	-49.07	-30.00	-19.07	3.56	Vertical	-52.63

**BT-LE(2Mbps)**  
**2402MHz\_TX**

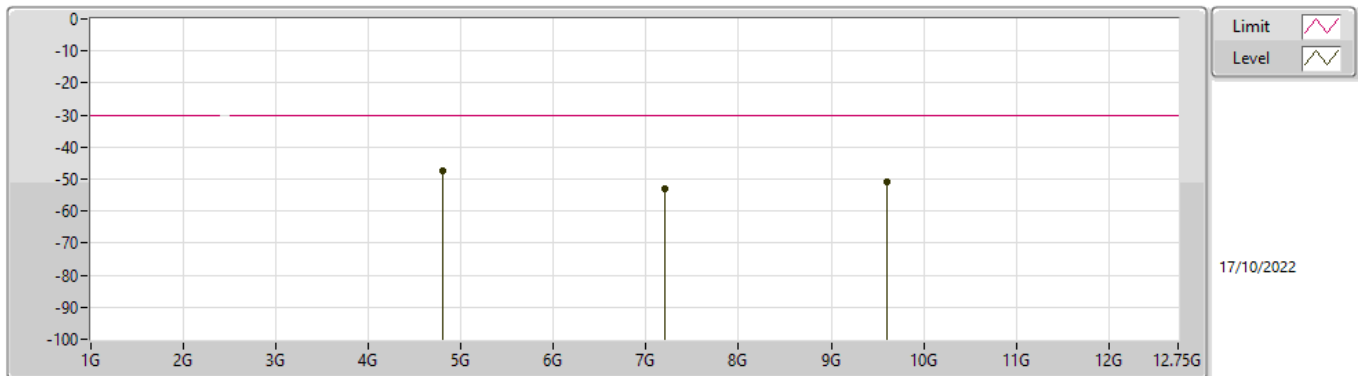

Freq (Hz)	Level (dBm)	Limit (dBm)	Margin (dB)	Factor (dB)	Condition	Raw (dBm)
4.80486G	-47.20	-30.00	-17.20	3.10	Horizontal	-50.30
7.20596G	-53.05	-30.00	-23.05	3.13	Horizontal	-56.18
9.60829G	-50.65	-30.00	-20.65	3.56	Horizontal	-54.21

**BT-LE(2Mbps)**  
**2480MHz\_TX**

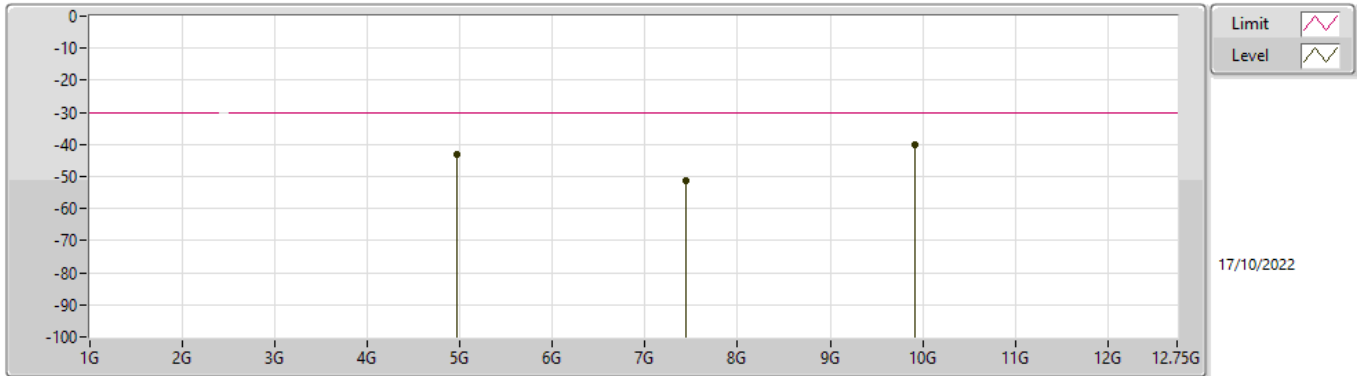

Freq (Hz)	Level (dBm)	Limit (dBm)	Margin (dB)	Factor (dB)	Condition	Raw (dBm)
4.96004G	-43.07	-30.00	-13.07	2.92	Vertical	-45.99
7.43831G	-51.39	-30.00	-21.39	2.87	Vertical	-54.26
9.91989G	-40.11	-30.00	-10.11	3.66	Vertical	-43.77

**BT-LE(2Mbps)**  
**2480MHz\_TX**

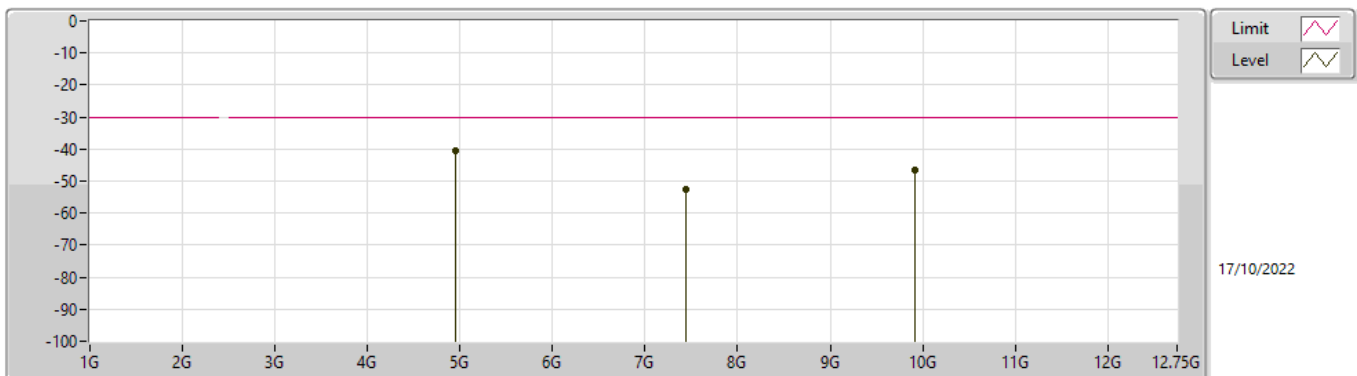

Freq (Hz)	Level (dBm)	Limit (dBm)	Margin (dB)	Factor (dB)	Condition	Raw (dBm)
4.9588G	-40.69	-30.00	-10.69	2.92	Horizontal	-43.61
7.43872G	-52.52	-30.00	-22.52	2.87	Horizontal	-55.39
9.91989G	-46.61	-30.00	-16.61	3.66	Horizontal	-50.27

**BT-LE(125kbps)**  
**2402MHz\_TX**

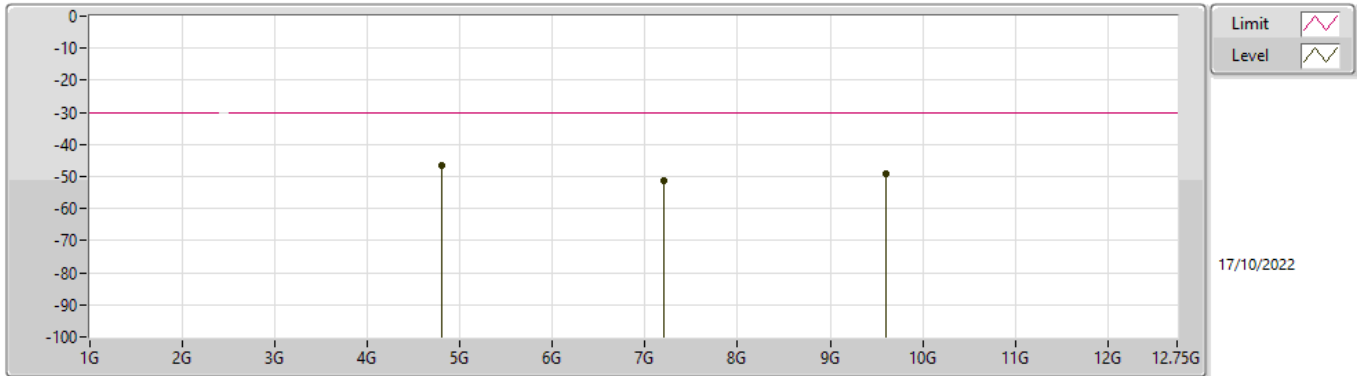

Freq (Hz)	Level (dBm)	Limit (dBm)	Margin (dB)	Factor (dB)	Condition	Raw (dBm)
4.80403G	-46.46	-30.00	-16.46	3.10	Vertical	-49.56
7.20554G	-51.35	-30.00	-21.35	3.13	Vertical	-54.48
9.60705G	-49.04	-30.00	-19.04	3.56	Vertical	-52.60

**BT-LE(125kbps)**  
**2402MHz\_TX**

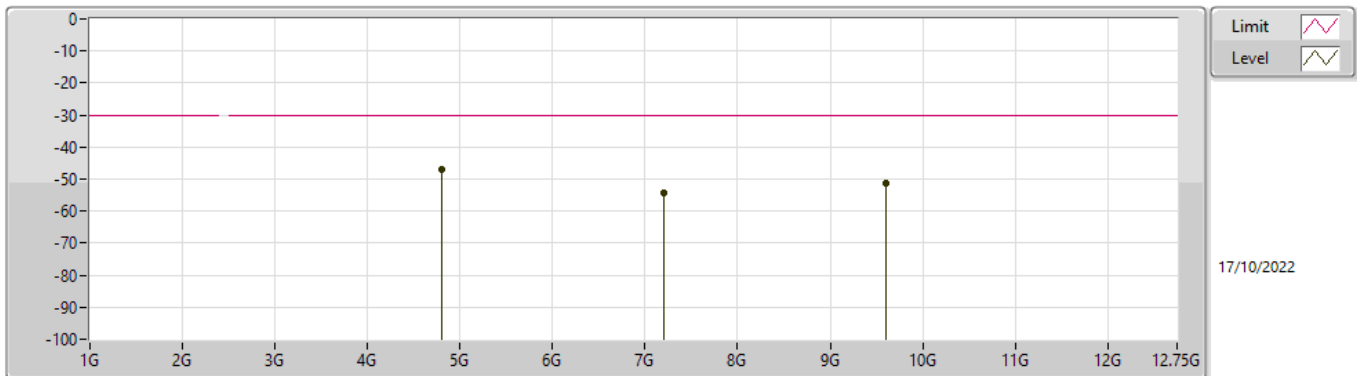

Freq (Hz)	Level (dBm)	Limit (dBm)	Margin (dB)	Factor (dB)	Condition	Raw (dBm)
4.80403G	-46.83	-30.00	-16.83	3.10	Horizontal	-49.93
7.20637G	-54.13	-30.00	-24.13	3.13	Horizontal	-57.26
9.60871G	-51.34	-30.00	-21.34	3.56	Horizontal	-54.90

**BT-LE(125kbps)**  
**2480MHz\_TX**

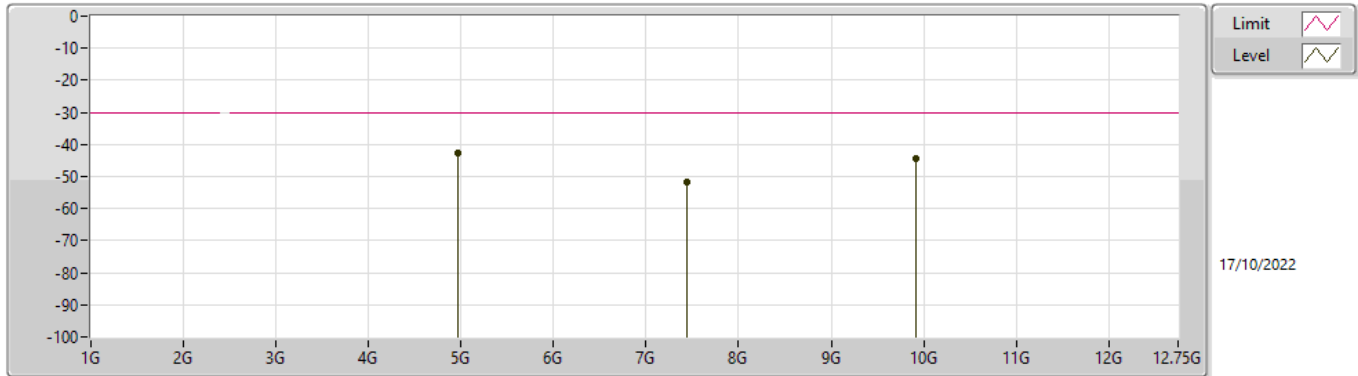

Freq (Hz)	Level (dBm)	Limit (dBm)	Margin (dB)	Factor (dB)	Condition	Raw (dBm)
4.96046G	-42.80	-30.00	-12.80	2.92	Vertical	-45.72
7.43955G	-51.67	-30.00	-21.67	2.87	Vertical	-54.54
9.92072G	-44.19	-30.00	-14.19	3.66	Vertical	-47.85

**BT-LE(125kbps)**  
**2480MHz\_TX**

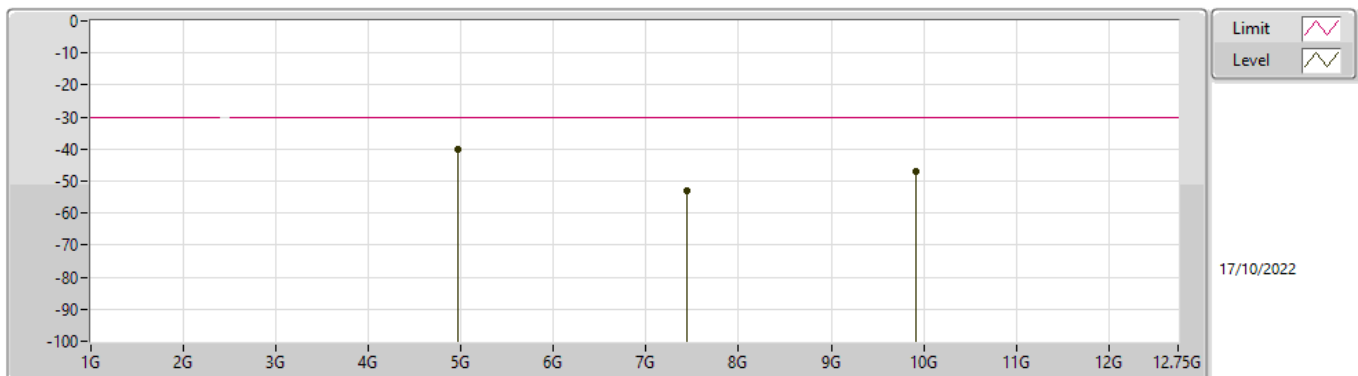

Freq (Hz)	Level (dBm)	Limit (dBm)	Margin (dB)	Factor (dB)	Condition	Raw (dBm)
4.95963G	-40.13	-30.00	-10.13	2.92	Horizontal	-43.05
7.4408G	-52.81	-30.00	-22.81	2.87	Horizontal	-55.68
9.92072G	-46.83	-30.00	-16.83	3.66	Horizontal	-50.49

**BT-LE(500kbps)**  
**2402MHz\_TX**

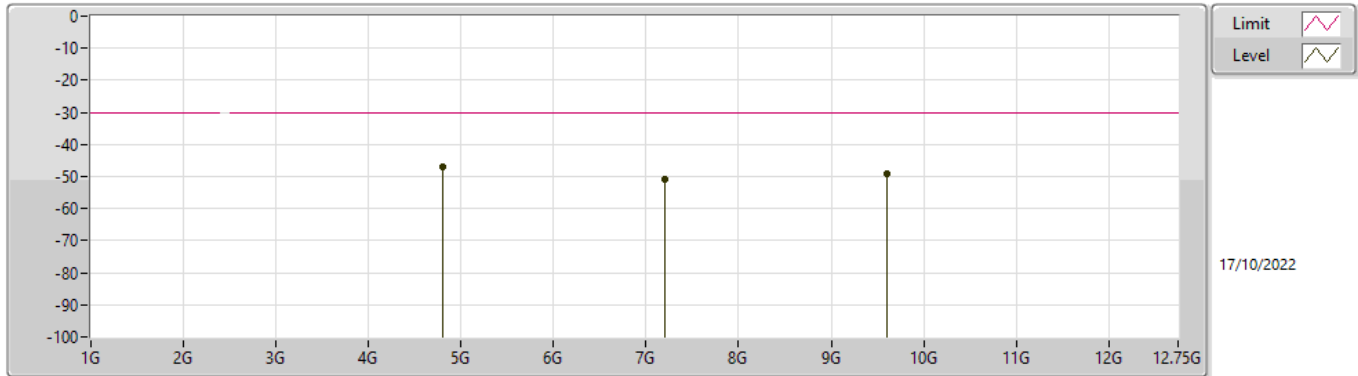

Freq (Hz)	Level (dBm)	Limit (dBm)	Margin (dB)	Factor (dB)	Condition	Raw (dBm)
4.80403G	-46.95	-30.00	-16.95	3.10	Vertical	-50.05
7.20513G	-51.07	-30.00	-21.07	3.13	Vertical	-54.20
9.60705G	-48.93	-30.00	-18.93	3.56	Vertical	-52.49

**BT-LE(500kbps)**  
**2402MHz\_TX**

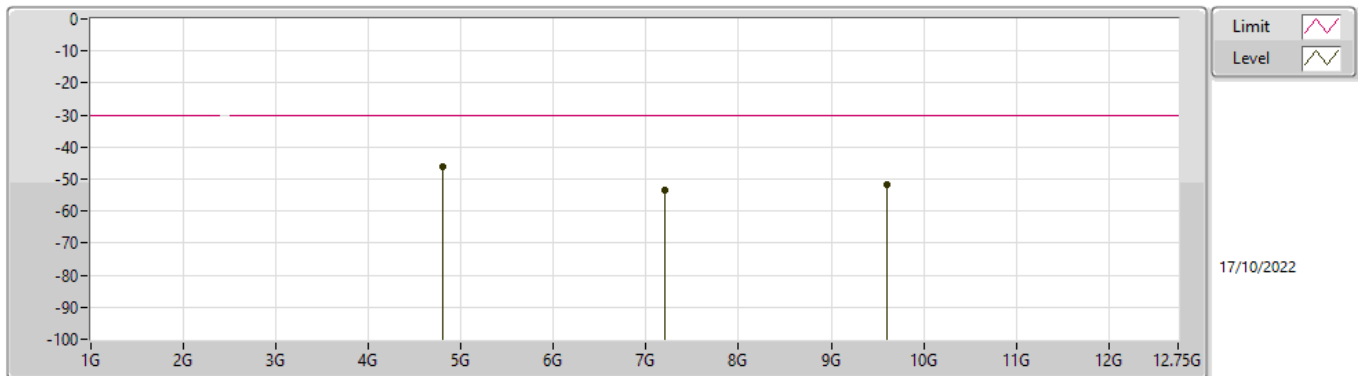

Freq (Hz)	Level (dBm)	Limit (dBm)	Margin (dB)	Factor (dB)	Condition	Raw (dBm)
4.80403G	-46.21	-30.00	-16.21	3.10	Horizontal	-49.31
7.20554G	-53.50	-30.00	-23.50	3.13	Horizontal	-56.63
9.60871G	-51.53	-30.00	-21.53	3.56	Horizontal	-55.09

**BT-LE(500kbps)**  
**2480MHz\_TX**

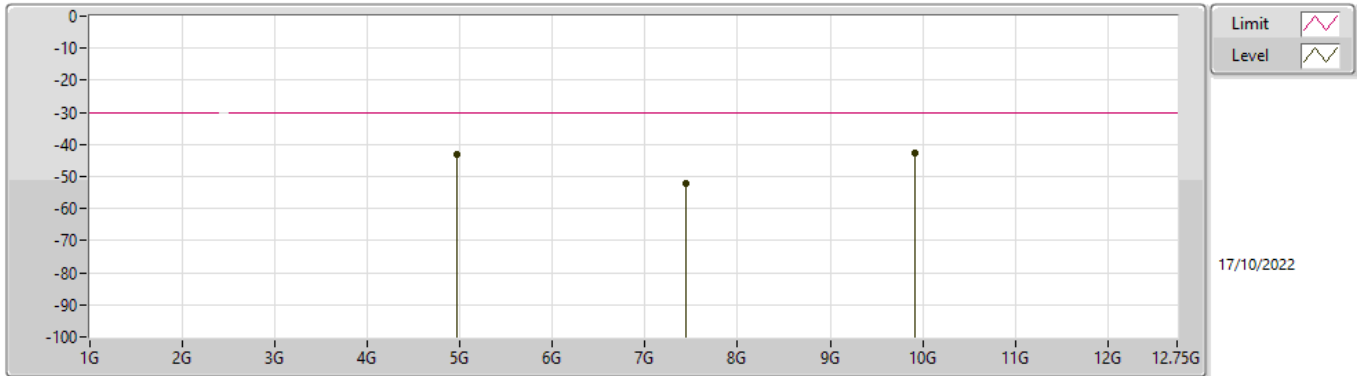

Freq (Hz)	Level (dBm)	Limit (dBm)	Margin (dB)	Factor (dB)	Condition	Raw (dBm)
4.96004G	-43.18	-30.00	-13.18	2.92	Vertical	-46.10
7.43997G	-52.19	-30.00	-22.19	2.87	Vertical	-55.06
9.92072G	-42.68	-30.00	-12.68	3.66	Vertical	-46.34

**BT-LE(500kbps)**  
**2480MHz\_TX**

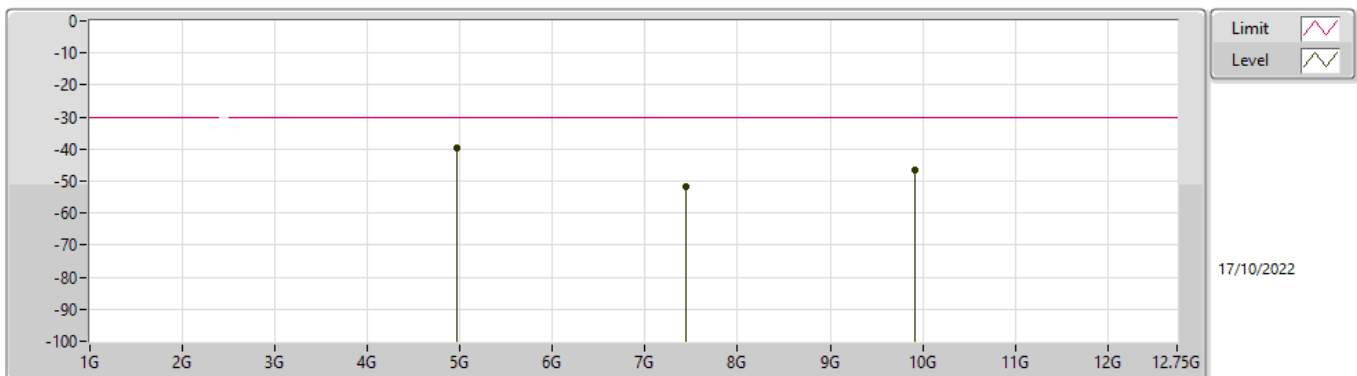

Freq (Hz)	Level (dBm)	Limit (dBm)	Margin (dB)	Factor (dB)	Condition	Raw (dBm)
4.95921G	-39.50	-30.00	-9.50	2.92	Horizontal	-42.42
7.43914G	-51.61	-30.00	-21.61	2.87	Horizontal	-54.48
9.91906G	-46.57	-30.00	-16.57	3.66	Horizontal	-50.23



Summary

Mode	Result	Type	Freq (Hz)	Level (dBm)	Limit (dBm)	Margin (dB)	Factor (dB)	Dist (m)	Condition	Azimuth (°)	Height (m)	Comments
2.4-2.4835GHz	-	-	-	-	-	-	-	-	-	-	-	-
BT-LE(2Mbps)	Pass	AV	528M	-59.21	-57.00	-2.21	7.75	3	Horizontal	345	1.5	TDP

Result

Mode	Result	Type	Freq (Hz)	Level (dBm)	Limit (dBm)	Margin (dB)	Factor (dB)	Dist (m)	Condition	Azimuth (°)	Height (m)	Comments
BT-LE(2Mbps)	-	-	-	-	-	-	-	-	-	-	-	-
2480MHz_RX	Pass	AV	96.8M	-63.64	-57.00	-6.64	0.74	3	Vertical	360	1.5	-
2480MHz_RX	Pass	AV	432.02M	-65.38	-57.00	-8.38	5.09	3	Vertical	360	1.5	-
2480MHz_RX	Pass	AV	480.02M	-66.39	-57.00	-9.39	5.89	3	Vertical	360	1.5	-
2480MHz_RX	Pass	AV	432M	-61.32	-57.00	-4.32	5.76	3	Horizontal	1	1.5	TDP
2480MHz_RX	Pass	AV	480.01M	-63.33	-57.00	-6.33	6.80	3	Horizontal	354	1.5	TDP
2480MHz_RX	Pass	AV	528M	-59.21	-57.00	-2.21	7.75	3	Horizontal	345	1.5	TDP

**BT-LE(2Mbps)**  
**2480MHz\_RX**

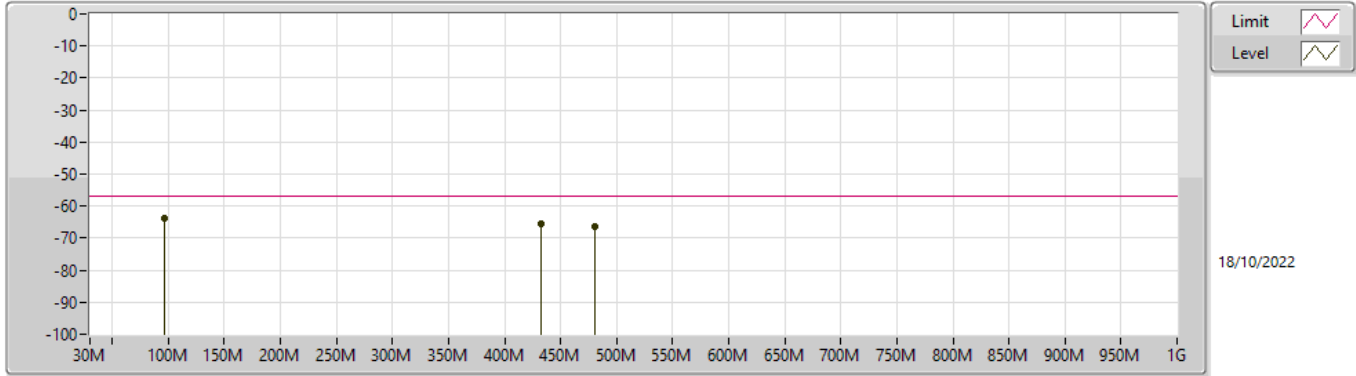

Type	Freq (Hz)	Level (dBm)	Limit (dBm)	Margin (dB)	Factor (dB)	Dist (m)	Condition	Azimuth (°)	Height (m)	Comment	Raw (dBm)
AV	96.8M	-63.64	-57.00	-6.64	0.74	3	Vertical	360	1.5	-	-64.38
AV	432.02M	-65.38	-57.00	-8.38	5.09	3	Vertical	360	1.5	-	-70.47
AV	480.02M	-66.39	-57.00	-9.39	5.89	3	Vertical	360	1.5	-	-72.28

**BT-LE(2Mbps)**  
**2480MHz\_RX**

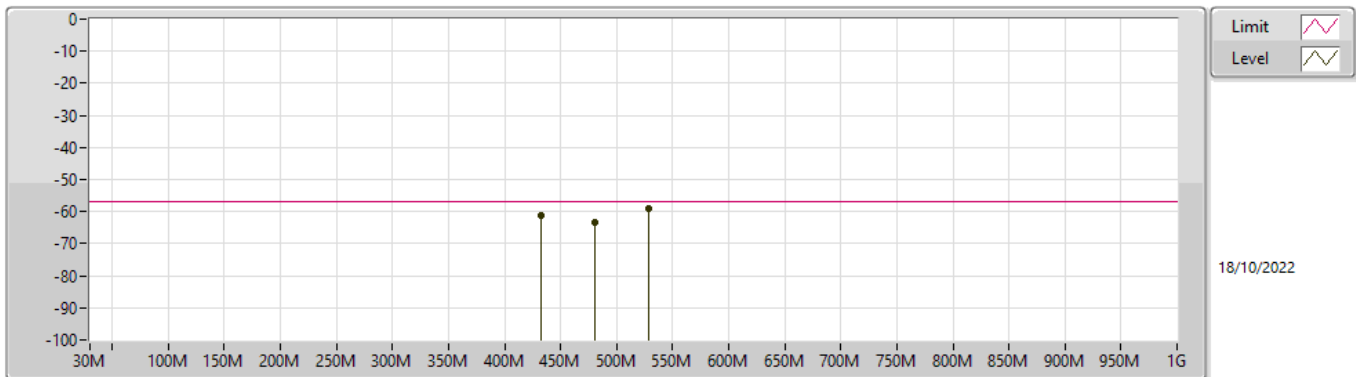

Type	Freq (Hz)	Level (dBm)	Limit (dBm)	Margin (dB)	Factor (dB)	Dist (m)	Condition	Azimuth (°)	Height (m)	Comment	Raw (dBm)
AV	432M	-61.32	-57.00	-4.32	5.76	3	Horizontal	1	1.5	TDP	-67.08
AV	480.01M	-63.33	-57.00	-6.33	6.80	3	Horizontal	354	1.5	TDP	-70.13
AV	528M	-59.21	-57.00	-2.21	7.75	3	Horizontal	345	1.5	TDP	-66.96



Summary

Mode	Result	Type	Freq (Hz)	Level (dBm)	Limit (dBm)	Margin (dB)	Factor (dB)	Dist (m)	Condition	Azimuth (°)	Height (m)	Comments
2.4-2.4835GHz	-	-	-	-	-	-	-	-	-	-	-	-
BT-LE(2Mbps)	Pass	AV	6.79225G	-55.31	-47.00	-8.31	3.40	3	Horizontal	0	1.5	-

Result

Mode	Result	Type	Freq (Hz)	Level (dBm)	Limit (dBm)	Margin (dB)	Factor (dB)	Dist (m)	Condition	Azimuth (°)	Height (m)	Comments
BT-LE(2Mbps)	-	-	-	-	-	-	-	-	-	-	-	-
2402MHz_RX	Pass	AV	2.80708G	-58.21	-47.00	-11.21	-0.18	3	Vertical	0	1.5	-
2402MHz_RX	Pass	AV	4.49865G	-55.65	-47.00	-8.65	3.45	3	Vertical	0	1.5	-
2402MHz_RX	Pass	AV	6.62424G	-55.47	-47.00	-8.47	3.43	3	Vertical	0	1.5	-
2402MHz_RX	Pass	AV	3.3791G	-57.71	-47.00	-10.71	0.69	3	Horizontal	360	1.5	-
2402MHz_RX	Pass	AV	5.7147G	-55.42	-47.00	-8.42	4.21	3	Horizontal	360	1.5	-
2402MHz_RX	Pass	AV	7.03726G	-55.46	-47.00	-8.46	3.32	3	Horizontal	360	1.5	-
2480MHz_RX	Pass	AV	3.71462G	-56.92	-47.00	-9.92	1.28	3	Vertical	360	1.5	-
2480MHz_RX	Pass	AV	5.7462G	-55.34	-47.00	-8.34	4.24	3	Vertical	360	1.5	-
2480MHz_RX	Pass	AV	6.66824G	-55.50	-47.00	-8.50	3.42	3	Vertical	360	1.5	-
2480MHz_RX	Pass	AV	2.59307G	-58.18	-47.00	-11.18	-0.56	3	Horizontal	0	1.5	-
2480MHz_RX	Pass	AV	5.39619G	-55.80	-47.00	-8.80	3.81	3	Horizontal	0	1.5	-
2480MHz_RX	Pass	AV	6.79225G	-55.31	-47.00	-8.31	3.40	3	Horizontal	0	1.5	-

**BT-LE(2Mbps)**

**2402MHz\_RX**

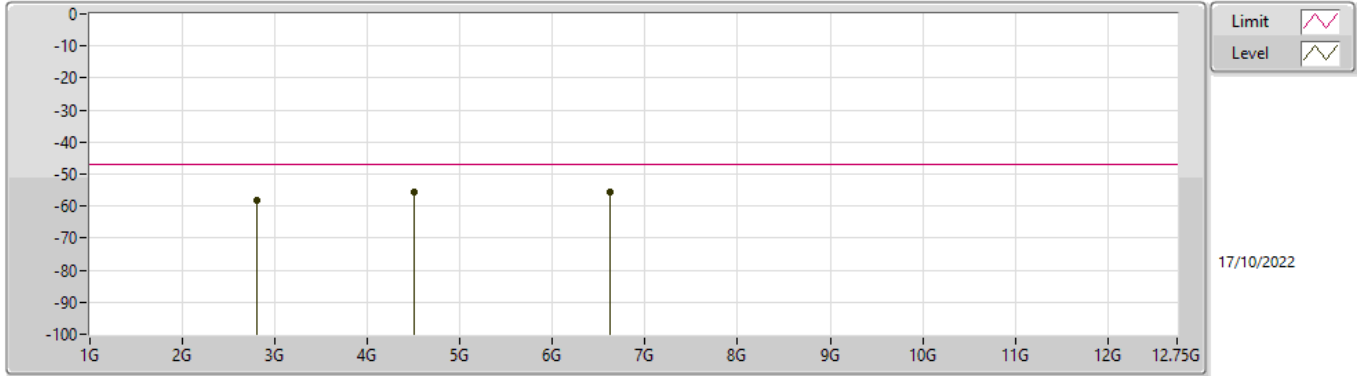

Freq (Hz)	Level (dBm)	Limit (dBm)	Margin (dB)	Factor (dB)	Condition	Raw (dBm)
2.80708G	-58.21	-47.00	-11.21	-0.18	Vertical	-58.03
4.49865G	-55.65	-47.00	-8.65	3.45	Vertical	-59.10
6.62424G	-55.47	-47.00	-8.47	3.43	Vertical	-58.90

**BT-LE(2Mbps)**

**2402MHz\_RX**

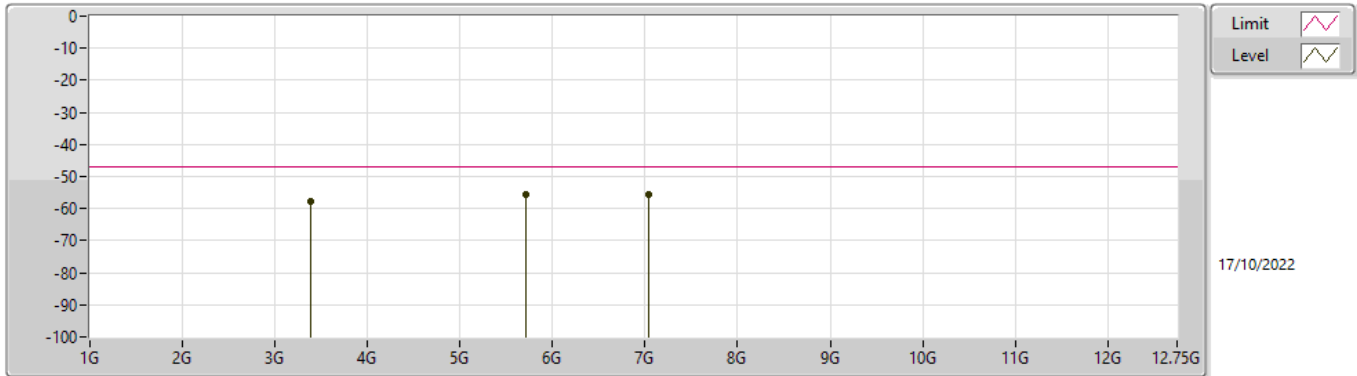

Freq (Hz)	Level (dBm)	Limit (dBm)	Margin (dB)	Factor (dB)	Condition	Raw (dBm)
3.3791G	-57.71	-47.00	-10.71	0.69	Horizontal	-58.40
5.7147G	-55.42	-47.00	-8.42	4.21	Horizontal	-59.63
7.03726G	-55.46	-47.00	-8.46	3.32	Horizontal	-58.78

**BT-LE(2Mbps)**  
**2480MHz\_RX**

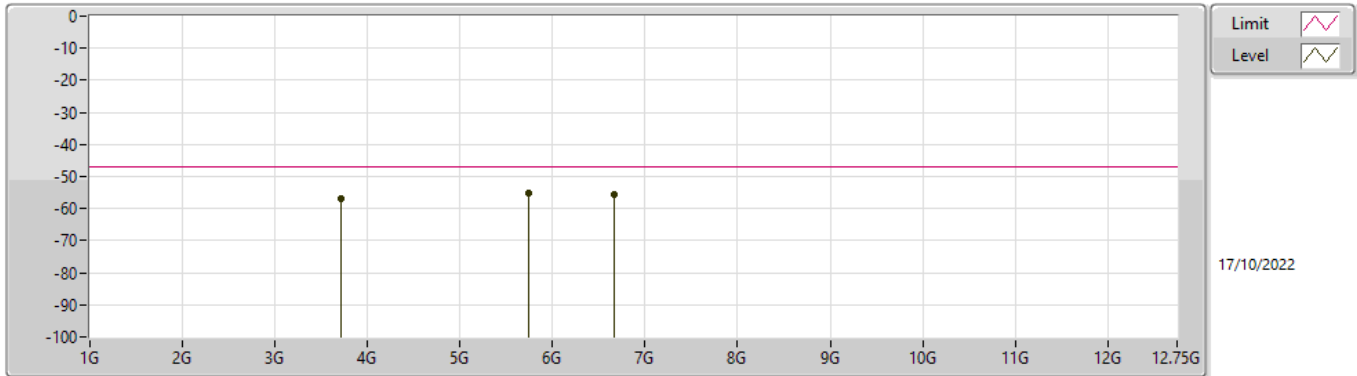

Freq (Hz)	Level (dBm)	Limit (dBm)	Margin (dB)	Factor (dB)	Condition	Raw (dBm)
3.71462G	-56.92	-47.00	-9.92	1.28	Vertical	-58.20
5.7462G	-55.34	-47.00	-8.34	4.24	Vertical	-59.58
6.66824G	-55.50	-47.00	-8.50	3.42	Vertical	-58.92

**BT-LE(2Mbps)**  
**2480MHz\_RX**

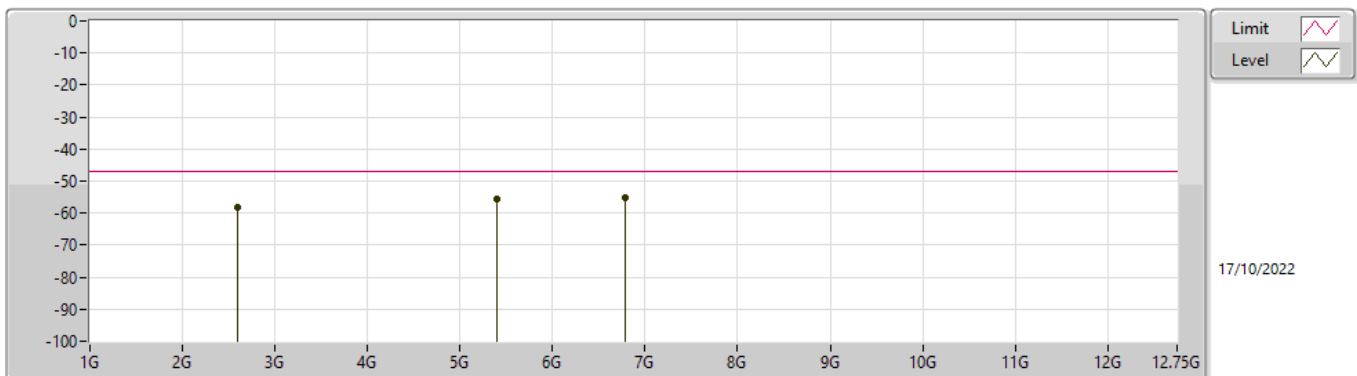

Freq (Hz)	Level (dBm)	Limit (dBm)	Margin (dB)	Factor (dB)	Condition	Raw (dBm)
2.59307G	-58.18	-47.00	-11.18	-0.56	Horizontal	-57.62
5.39619G	-55.80	-47.00	-8.80	3.81	Horizontal	-59.61
6.79225G	-55.31	-47.00	-8.31	3.40	Horizontal	-58.71

Receiver Blocking Result						
<b>P<sub>min</sub>(dBm)</b>	-102.0					
Modulation Mode	Operation Frequency (MHz)	Wanted Signal Mean Power from Companion Device (dBm)	Receiver Blocking Power (dBm)	Blocking Signal Frequency (MHz)	Type of Blocking Signal	Test Result
LE(125k)	2402	-66	-31.6	2380	CW	Pass
	2402	-66	-31.6	2300	CW	Pass
<b>Limit</b>	PER(Packet Error Rate) ≤ 10%					
<b>Result</b>	<b>Complied</b>					

Receiver Blocking Result						
<b>P<sub>min</sub>(dBm)</b>	-101.0					
Modulation Mode	Operation Frequency (MHz)	Wanted Signal Mean Power from Companion Device (dBm)	Receiver Blocking Power (dBm)	Blocking Signal Frequency (MHz)	Type of Blocking Signal	Test Result
LE(125k)	2480	-66	-31.6	2504	CW	Pass
	2480	-66	-31.6	2584	CW	Pass
<b>Limit</b>	PER(Packet Error Rate) ≤ 10%					
<b>Result</b>	<b>Complied</b>					

## 1. Photographs of Radiated Emissions Test Configuration

Front view



Rear view

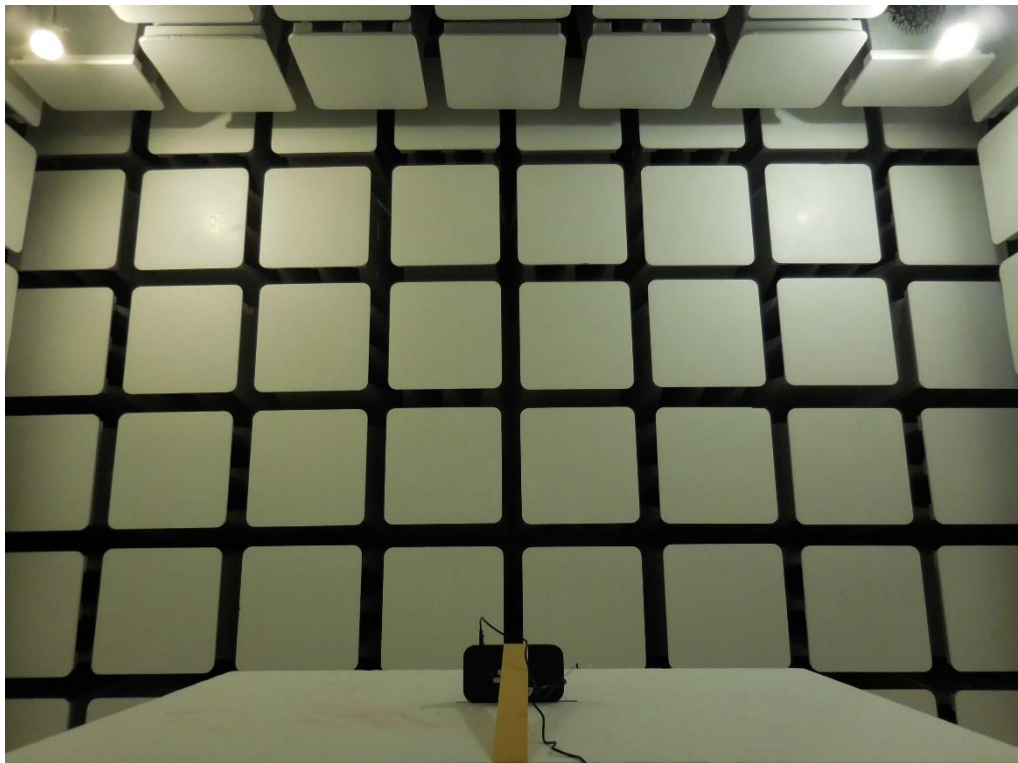

Bilog Antenna

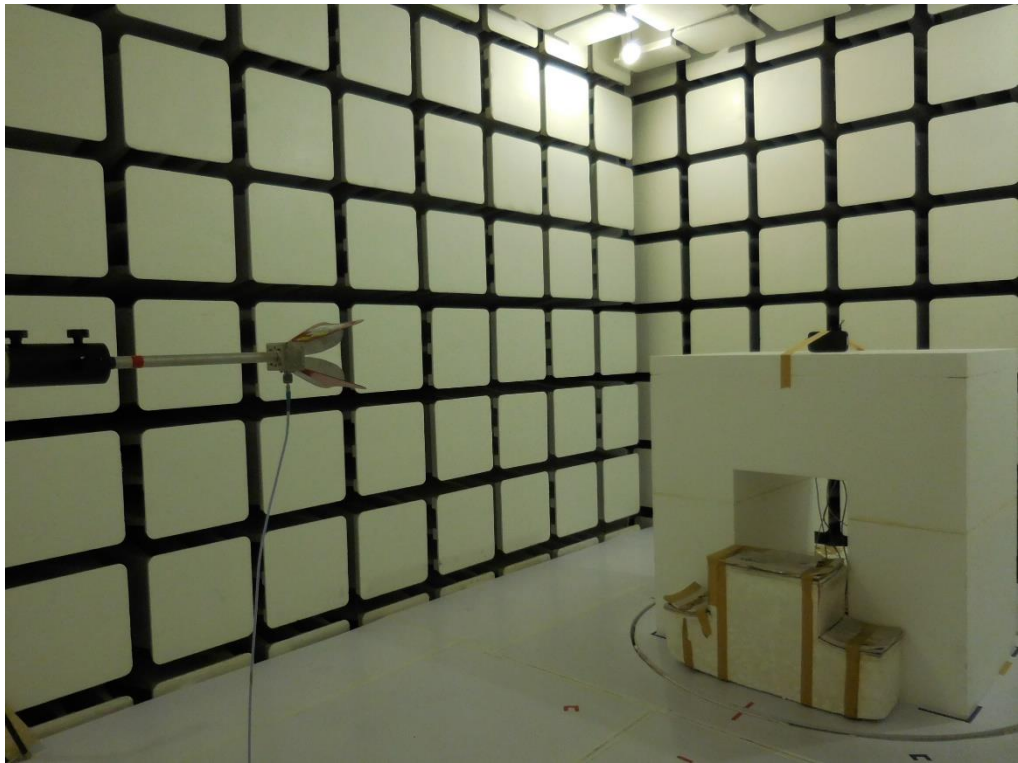

Horn Antenna

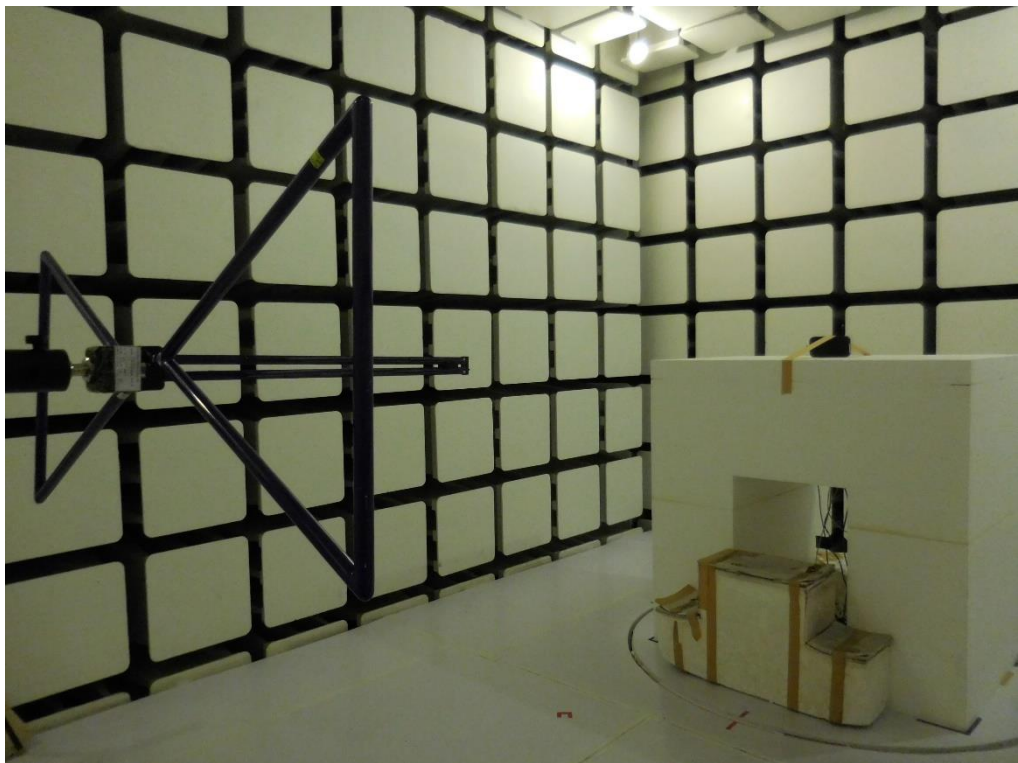

EUT take a close-up

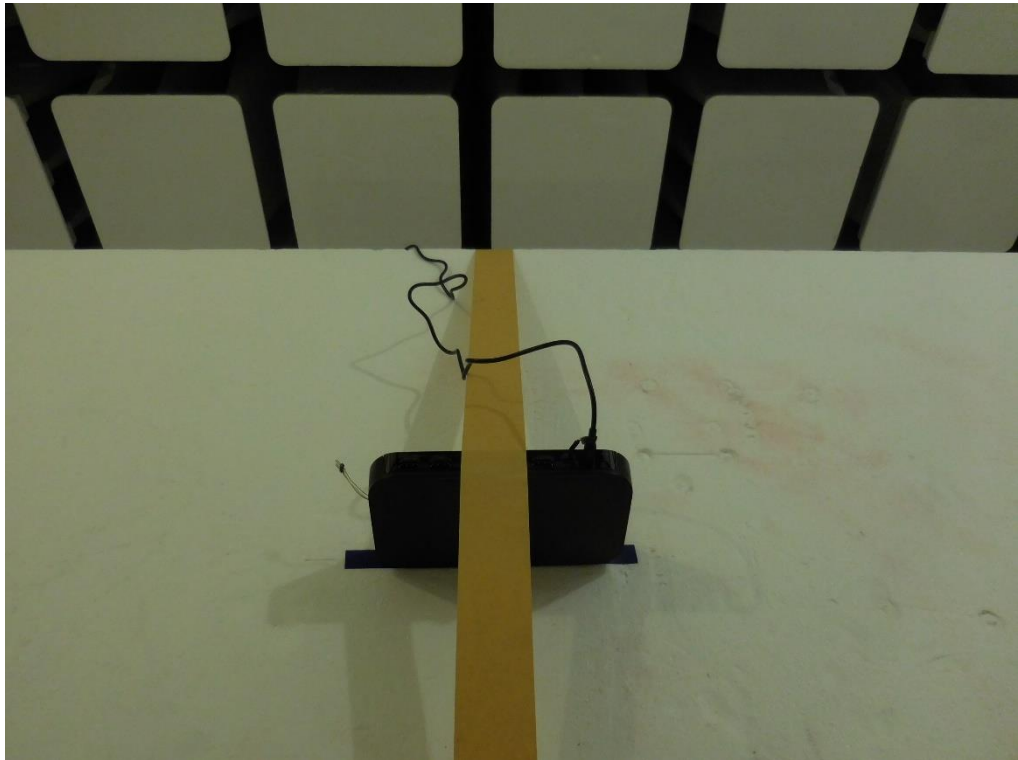

EUT take a close-up

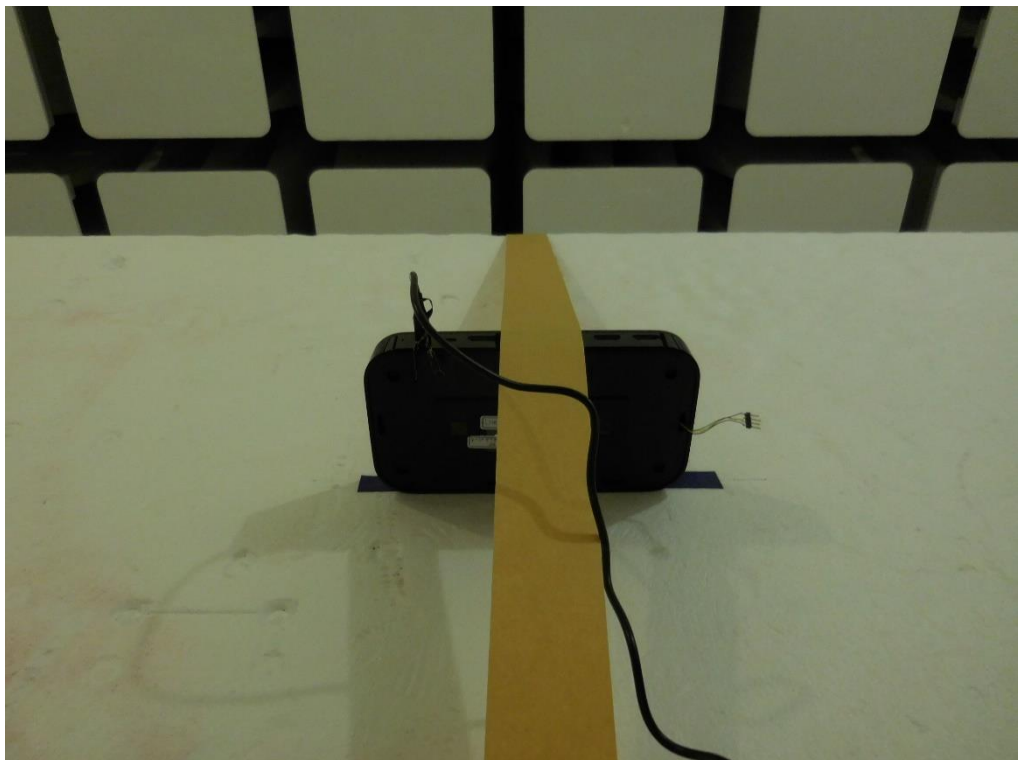

## 2. Photographs of Receiver Blocking Test Configuration

Front view



EUT take a close-up

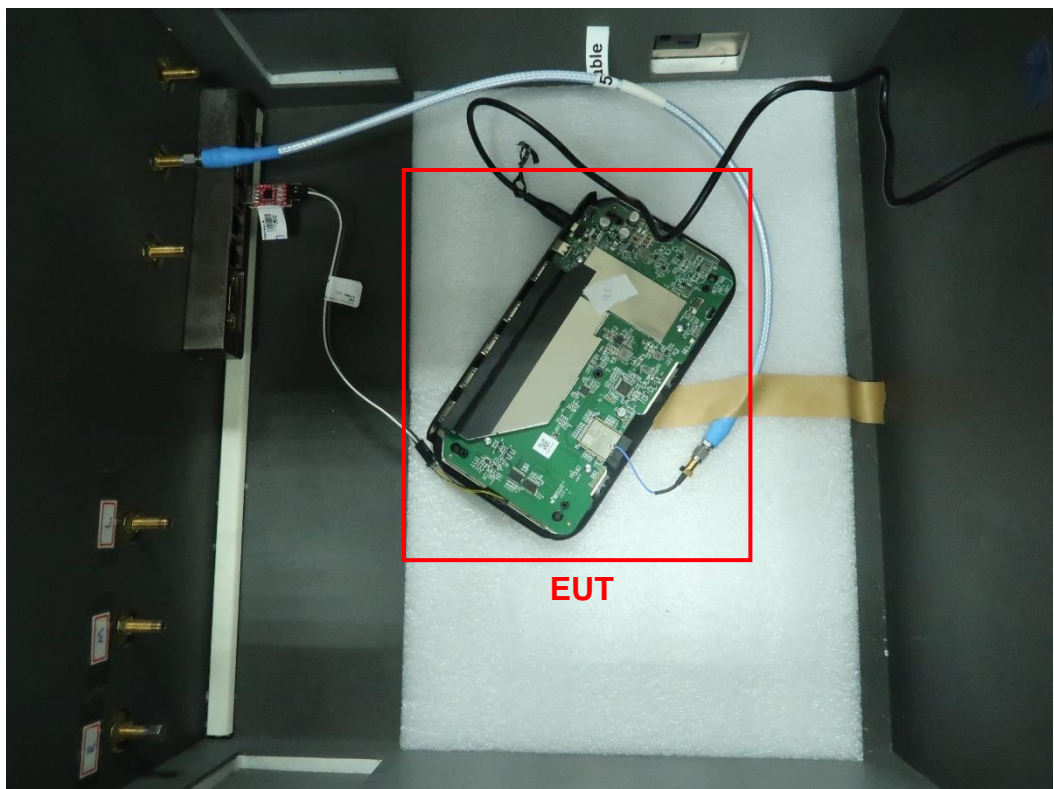

—————THE END—————