

RESOLUCION 737 - SUBTEL

Fecha de publicación: 13/3/2026

Información Comercial

Nombre comercial del equipo

Código	Descripción
929003498601	Gradient PC strip 32 34 inch EU

Fabricante: Signify (China) Investment Co., Ltd.

Importador o representante en Chile: SIGNIFY CHILENA S.A.

Domicilio: El Bosque Norte 0211, Las Condes - Santiago

Correo electrónico de contacto: tomas.aragona@signify.com

Sitio Web: philips-hue.com/es-cl

Características técnicas

Tipo de equipo	Tira LED
Marca	Hue
Modelo	Gradient PC strip 32 34 inch EU
Módulo	EFR32RM21
Tecnología o modulación	O-QPSK PHY (Zigbee); GFSK (BLE)
Frecuencias	BLE: 2402-2480 MHz; Zigbee: 2405-2480 MHz.
Ganancia de antena (dBi)	2.08 dBi
P.I.R.E. (EIRP)	BLE: 5,2 mW (7,16 dBm); Zigbee: 8,61 mW (9,35 dBm).

Declaración de conformidad

“El equipo previamente individualizado cumple con las disposiciones establecidas en la Norma Técnica de Equipos de alcance reducido, aprobada por la resolución exenta N° 1.985, de 2017, de la Subsecretaría de Telecomunicaciones.”

Firma del Importador/Responsable:

Nombre de quien firma: Tomás Aragona



Cargo: Representante Legal

- ANT.: 1. Ingreso SUBTEL N° 41333 de 27.03.2024.
2. Resolución Exenta N° 1.985 de 2017, y sus modificaciones, de la Subsecretaría de Telecomunicaciones.
3. Resolución Exenta N° 3.103 de 2012, de la Subsecretaría de Telecomunicaciones.
4. Resolución Exenta N°470 de 13/02/2013, que faculta a los Jefes de División y Departamento para firmar "Por Orden del Señor Subsecretario" y delega las facultades que indica.

MAT.: Certifica equipos de alcance reducido.

DE: SUBSECRETARÍA DE TELECOMUNICACIONES

A: SIGNIFY CHILENA S.A.

1. De acuerdo a la información proporcionada por documento de ANT. 1), esta Subsecretaría de Estado extiende el presente certificado para operar dentro del país, condicionado al estricto cumplimiento de lo señalado en letra j.1, del artículo 1° de la norma señalada en ANT. 2):

- Tipo de Equipo : Tira LED
- Marca : HUE
- Modelo : 9290034986
- Fabricante : Signify (China) Investment Co., Ltd.
- Frecuencias de operación : BLE: 2402-2480 MHz; Zigbee: 2405-2480 MHz.
- Potencia máxima radiada : BLE: 5,2 mW (7,16 dBm); Zigbee: 8,61 mW (9,35 dBm).
- Restricciones : Estos equipos deben emplear técnicas que permitan la compartición de frecuencias.

2. El incumplimiento de lo dispuesto por el presente certificado, será sancionado de acuerdo a las disposiciones legales vigentes. Estos equipos no deberán provocar interferencias a servicios de concesionarias de telecomunicaciones y no estarán protegidos respecto de interferencias que eventualmente puedan recibir.

Saluda atentamente a Ud.,
Por orden del Subsecretario de Telecomunicaciones

DISTRIBUCIÓN:

- Signify Chilena S.A. : ivan.ruhl@intertek.com
- Oficina de Partes.

Francisco Javier Pizarro Sepulveda
Jefe División Fiscalización
09/05/2024 10:29





RF - TEST REPORT

Report Number : **709502203711-01B** Date of Issue: July 20, 2022

Model : 9290034985,9290034986,9290034987

Product Type : **Rope light**

Applicant : Signify (China) Investment Co., Ltd.

Address : Building No. 9, Lane 888, Tianlin Road

Minhang 200233 Shanghai PEOPLE'S REPUBLIC OF CHINA

Manufacturer : Signify (China) Investment Co., Ltd.

Address : Building No. 9, Lane 888, Tianlin Road

Minhang 200233 Shanghai PEOPLE'S REPUBLIC OF CHINA

Test Result : Positive Negative

Total pages including Appendices : 40



TÜV SÜD Certification and Testing (China) Co., Ltd. – Shanghai Branch is a subcontractor to TÜV SÜD Product Service GmbH according to the principles outlined in ISO 17025.

TÜV SÜD Certification and Testing (China) Co., Ltd. – Shanghai Branch reports apply only to the specific samples tested under stated test conditions. Construction of the actual test samples has been documented. It is the manufacturer's responsibility to assure that additional production units of this model are manufactured with identical electrical and mechanical components. The manufacturer/importer is responsible to the Competent Authorities in Europe for any modifications made to the production units which result in non-compliance to the relevant regulations. TÜV SÜD Certification and Testing (China) Co., Ltd. – Shanghai Branch shall have no liability for any deductions, inferences or generalizations drawn by the client or others from TÜV SÜD Certification and Testing (China) Co., Ltd. – Shanghai Branch issued reports.

This report is the confidential property of the client. As a mutual protection to our clients, the public and ourselves, extracts from the test report shall not be reproduced except in full without our written approval

Table of Content

1	Report Version	4
2	General Information	5
2.1	Notes	5
2.2	Testing Laboratory	6
2.3	Details of Applicant	6
2.4	Application Details	6
2.5	Applied Standard	7
2.6	Test Summary	7
3	Equipment Specification.....	8
3.1	General Description	8
3.2	EUT Identity	8
3.3	Product Description –manufacturer description	9
3.4	Operating Frequency Range, Modulation and Throughput	10
3.5	Additional information	11
4	General Test Conditions / Configurations	12
4.1	Test Sample.....	12
4.2	Test Modes	12
4.3	Frequencies under Test	12
4.4	Test Setups	12
4.5	Test Conditions.....	15
5	Test Results	17
6	Test Requirements	18
6.1	RF output power	18
6.2	Maximum EIRP Spectral Density	18
6.3	Adaptivity	18
6.4	Occupied Channel Bandwidth	18
6.5	Transmitter unwanted emissions in the out-of-band domain	19
6.6	Transmitter Spurious Emissions	19
6.7	Receiver Spurious Emissions.....	20
6.8	Receiver Blocking	20
6.9	Estimation of Exposure of Human to Electromagnetic Fields	22
7	Main Test Instruments	23
8	System Measurement Uncertainty.....	24



China

9	Appendix A: RF output power.....	25
10	Appendix B: Maximum EIRP Spectral Density.....	27
11	Appendix C: Occupied Channel Bandwidth.....	27
12	Appendix D: Transmitter unwanted emissions in the out-of-band domain.....	28
13	Appendix E: Transmitter Spurious Emissions – Radiated Mode.....	29
14	Appendix F: Receiver Spurious Emissions-Radiated Mode.....	32
15	Appendix G: Receiver Blocking.....	33
16	Appendix H: Test Setup Photos.....	34
17	Appendix I: Photographs of EUT.....	35

1 Report Version

Revision	Release Date	History/Memo.
1.0	May 10, 2022	Initial Release
2.0	July 20,2022	Only changed the product name from “LED device” to “Rope light”. This revised report replaced all the version issued before.



2 General Information

2.1 Notes

TÜV SÜD Certification and Testing (China) Co., Ltd. – Shanghai Branch is a subcontractor to TÜV SÜD Product Service GmbH according to the principles outlined in ISO 17025.

TÜV SÜD Certification and Testing (China) Co., Ltd. – Shanghai Branch reports apply only to the specific samples tested under stated test conditions. Construction of the actual test samples has been documented. It is the manufacturer's responsibility to assure that additional production units of this model are manufactured with identical electrical and mechanical components. The manufacturer/importer is responsible to the Competent Authorities in Europe for any modifications made to the production units which result in non-compliance to the relevant regulations. TÜV SÜD Certification and Testing (China) Co., Ltd. – Shanghai Branch shall have no liability for any deductions, inferences or generalizations drawn by the client or others from TÜV SÜD Certification and Testing (China) Co., Ltd. – Shanghai Branch issued reports.

This report is the confidential property of the client. As a mutual protection to our clients, the public and ourselves, extracts from the test report shall not be reproduced except in full without our written approval.

The sample's mentioned in this report is/are submitted/ supplied/ manufactured by client. The laboratory therefore assumes no responsibility for accuracy of information on the brand name, model number, origin of manufacture, consignment, antenna gain or any information supplied.

Prepared by
Project Engineer

2022-07-20
Date

Jiaxi XU
Name

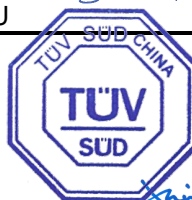

Jiaxi Xu
Signature

Approved by
Review Engineer

2022-07-20
Date

Zhining ZHANG
Name

Signature



2.2 Testing Laboratory

Site 1

Company name: TÜV SÜD Certification and Testing (China) Co., Ltd. Shanghai Branch

Company Address: No.16 Lane, 1951 Du Hui Road,
Shanghai 201108,
P.R. China

Telephone: +86 21 6141 0123

Fax: +86 21 6140 8600

2.3 Details of Applicant

Client: Signify (China) Investment Co., Ltd.
Address: Building No. 9, Lane 888, Tianlin Road
Minhang 200233 Shanghai PEOPLE'S REPUBLIC OF CHINA
Product Description: Rope light
Submitted Model No.: 9290034985,9290034986,9290034987

2.4 Application Details

Date of receipt of test item: January 21, 2022
Date of test: January 23, 2022 ~ March 10, 2022

2.5 Applied Standard

APPLIED PRODUCT STANDARD **ETSI EN 300 328 V2.2.2 (2019-07)**
EN 62479:2010
EN 50663:2017

2.6 Test Summary

Table1. Summary of results

Conformance requirement according to ETSI EN 300 328 V2.2.2 (2019-07)		Result	Test Site
Essential parameter	Corresponding technical requirements		
Transmitter requirements	4.3.1.2/4.3.2.2 RF output power	PASS	Site 1
	4.3.2.3 Power Spectral Density	PASS	Site 1
	4.3.1.3/4.3.2.4 Duty Cycle, Tx-sequence, Tx-gap**	N/A	N/A
	4.3.1.4 Dwell time, Minimum Frequency Occupation and Hopping Sequence*	N/A	N/A
	4.3.1.5 Hopping Frequency Separation*	N/A	N/A
	4.3.1.6/4.3.2.5 Medium Utilisation (MU) factor**	N/A	N/A
	4.3.1.7/4.3.2.6 Adaptivity****	N/A	N/A
	4.3.1.8/4.3.2.7 Occupied Channel Bandwidth	PASS	Site 1
	4.3.1.9/4.3.2.8 Transmitter unwanted emissions in the out-of-band domain	PASS	Site 1
	4.3.1.10/4.3.2.9 Transmitter unwanted emissions in the spurious domain	PASS	Site 1
Receiver requirements	4.3.1.11/4.3.2.10 Receiver spurious emissions	PASS	Site 1
	4.3.1.12/4.3.2.11 Receiver Blocking	PASS	Site 1
	4.3.1.13/4.3.2.12 Geo-location capability***	N/A	N/A

NOTE1: Measurement taken is within the measurement uncertainty of measurement system.

NOTE2: "*" This requirement applies to all types of equipment using FHSS other than wide band modulations.

NOTE3: "***" This requirement does not apply to adaptive equipment unless operating in a non-adaptive mode.

NOTE4: "****" This requirement only applies to equipment with geo-location capability.

NOTE5: "*****" These requirements do not apply for equipment with a maximum declared RF Output power of less than 10 dBm e.i.r.p.

3 Equipment Specification

3.1 General Description

The EUT is a Rope light with Zigbee and BLE function. This report is only for 2.4G BLE, for the 2.4GHz Zigbee test report please refer to 709502203711-00C.

There are 3 models in all, only different is the size of the Rope light. We chose model 9290034987 to perform all tests and listed the worst data in this report.

3.2 EUT Identity

NOTE: Unless otherwise noted in the report, the functional boards installed in the units shall be selected from the below list, but not means all the functional boards listed below shall be installed in one unit.

3.2.1 Technical data

Description:	Rope light
Models:	9290034985,9290034986,9290034987
Hardware version	V1.X
Software version	V1.X
Input Rated Voltage	220-240V~, 50/60Hz

Operation Frequency each of channel: Zigbee			
Channel	Fre(MHz)	Channel	Fre(MHz)
11	2405	19	2445
12	2410	20	2450
13	2415	21	2455
14	2420	22	2460
15	2425	23	2465
16	2430	24	2470
17	2435	25	2475
18	2440	26	2480

Operation Frequency each of channel: Bluetooth Low Energy							
Ch	Fre (MHz)	Ch	Fre(MHz)	Ch	Fre(MHz)	Ch	Fre(MHz)
0	2402	10	2422	20	2442	30	2462
1	2404	11	2424	21	2444	31	2464
2	2406	12	2426	22	2446	32	2466
3	2408	13	2428	23	2448	33	2468
4	2410	14	2430	24	2450	34	2470
5	2412	15	2432	25	2452	35	2472
6	2414	16	2434	26	2454	36	2474
7	2416	17	2436	27	2456	37	2476
8	2418	18	2438	28	2458	38	2478
9	2420	19	2440	29	2460	39	2480

Remark 1: The above EUT's information is declared by manufacturer. Please refer to the specifications or user's manual for more detailed description.

3.3 Product Description –manufacturer description

3.3.1 Type of Tested Equipment

<input checked="" type="checkbox"/> BLE	<input type="checkbox"/> IEEE 802.11	Other supply full details: _____	
<input checked="" type="checkbox"/> Stand-alone	<input type="checkbox"/> Plug-in radio	<input type="checkbox"/> Combined equipment	<input type="checkbox"/> Other

3.3.2 Extreme operating condition as declared by manufacturer

Power source description		
<input checked="" type="checkbox"/> AC mains voltage		<input type="checkbox"/> DC voltage Nominal
Type of DC		
<input type="checkbox"/> Internal Power Supply	<input type="checkbox"/> External AC/DC Adapter	<input type="checkbox"/> Battery <input type="checkbox"/> Other
Extreme Test Voltage [manufacturer declared]		
VN = Nominal voltage [V]	VH = Max Voltage [V]	VL = Min Voltage [V]
230V~	240V~	220V~

EXTREME TEMPERATURE RANGE [manufacturer declared]			
Environment class /Operating Temperature	TL = Minimum Temperature [°C]	TN = Normal Temperature [°C]	TH = Maximum Temperature [°C]
<input checked="" type="checkbox"/> Other [declared by manufacturer in UM]	-20	25	75

3.3.3 Type of adaptivity used

<input type="checkbox"/> Non-adaptive	<input checked="" type="checkbox"/> Adaptive	<input checked="" type="checkbox"/> LBT	<input type="checkbox"/> Non LBT
	<input type="checkbox"/> The system can operate in more than one adaptive mode	<input checked="" type="checkbox"/> System can operate both adaptive & non adaptive mode	
	<input type="checkbox"/> Frame Based Equipment	<input checked="" type="checkbox"/> Load Based Equipment	
		CCA time implemented [uS]	>20
		q as referred by 4.3.2.5.2.2.2	4-32

3.3.4 Antenna Assemblies Profiles

Antenna Type	<input checked="" type="checkbox"/> Integrated	<input type="checkbox"/> External	
Temporary RF connector	<input checked="" type="checkbox"/> Provided	<input type="checkbox"/> Not- provided	
<input checked="" type="checkbox"/> SISO - Single antenna equipment	Antenna [dBi] =		2.08dBi
<input type="checkbox"/> MIMO - Multiple antenna without beam forming	Number of transmit antennas=		1
<input type="checkbox"/> MIMO/B - Multiple antenna with beam forming	Beam forming gain [dB] Y =	
Number of receive chains	1	<input type="checkbox"/> Symmetrical power distribution	
Number of transceive chains	1	<input type="checkbox"/> Asymmetrical power distribution	
<input type="checkbox"/> Tx power control (TPC) (antenna connector with multiple power setting)	Nr. of different power level	

3.4 Operating Frequency Range, Modulation and Throughput

Transmitter / Receiver Frequency Range			
<input checked="" type="checkbox"/>	Range 1 : from :	2400 MHz	To 2483.5 MHz
<input type="checkbox"/>	Range 2 : from :		
<input type="checkbox"/>	Other - (include frequency ranges supported):		

Modulation type	
<input checked="" type="checkbox"/>	GFSK (1Mbps,2Mbps,500Kbps,125Kbps)
<input type="checkbox"/>	$\pi/4$ -DQPSK
<input type="checkbox"/>	8-DPSK
<input type="checkbox"/>	16-ary orthogonal modulation, O-QPSK PHY
<input type="checkbox"/>	IEEE 802.11™ [i.3] modulations using a single or multiple transmitters with or without transmit CSD.
<input type="checkbox"/>	HT20: 20 MHz channels with one to four spatial streams (MCS 0 to MCS 76).
<input type="checkbox"/>	HT40: 40 MHz channels with one to four spatial streams (MCS 0 to MCS 76).

3.5 Additional information

The transmitter can operate only:

- Modulated**
- Un-modulated**

ITU Class of emissions 1. 22

Duty Cycle: The transmitter is intended for

- Continuous duty**
- Intermittent duty**
- Continuous operation possible for testing purposes**

About the EUT:

- The equipment submitted are representative production models.**
- If not, the equipment submitted are pre-production models.**
- If preproduction equipment are submitted, the final production equipment will be identical in all respects with the equipment tested.**
- If not, supply full details: _____**



4 General Test Conditions / Configurations

4.1 Test Sample

- The report applies to single model number.
- The report applies to several models. The practical measurements are performed using the model number of 929034987.

4.2 Test Modes

Test Mode	Test Modes Description
BLE	TX and RX

4.3 Frequencies under Test

Test Mode	RF Channel		
	Lowest/Bottom (B)	Middle (M)	Highest/Top (T)
BLE	Ch No. 11 / 2402 MHz	Ch No. 19 / 2440 MHz	Ch No. 39 / 2480 MHz

4.4 Test Setups

NOTE: See Appendix H for practical Test Setup Photos.

4.4.1 General Test Setup Configurations

Configuration	Description
Test Antenna Ports	Until declared, all Transmitter tests are performed at all antenna ports of the EUT; all Receiver tests are performed at all antenna ports.
Multiple RF Sources	Other non-BLE RF source(s) (if applicable) of the EUT are disabled or shutdown during measurements for BLE RF source, which is considered in the present report.

4.4.2 Test Setup for Conducted Measurements

The EUT (BLE unit) is placed in a Temperature Chamber (if applicable), and is powered by a Power Supplier. An external Control PC associated with special software(s) is used to configure the EUT (BLE unit) with the purpose of fulfilling the test requirements by EN standard.

The antenna port(s) of the EUT (BLE unit) are connected to the Measurement Instrument(s) through an appropriate Attenuator. For the antenna port(s) which are not tested, appropriate 50 Ohm terminations are used.

In addition, different setting options (e.g. Option 1) for Measurement Instrument(s) for conducted measurement methods can be used for some test items according to the EN standard. The selected option is specified in test conditions for each test case.

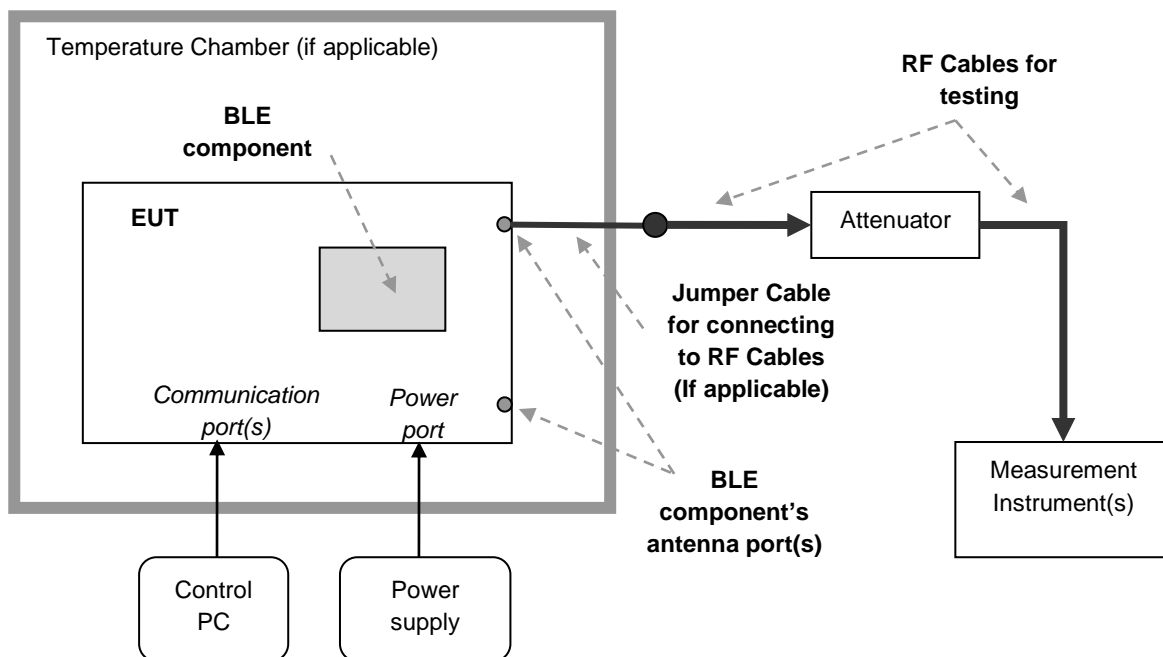

4.4.3 Test Setup for Radiated Measurements

The EUT (BLE unit) is placed in a Fully Anechoic Chamber simulating the free-space conditions. The whole device is positioned on a non-conducting support and is powered by a Power Supplier. An external Control PC associated with special software(s) is used to configure the EUT (BLE unit) with the purpose of fulfilling the test requirements by EN standards.

An appropriate Measurement Antenna (according to different test frequency ranges) with the distance of 3 m to the whole device is used to obtain maximum response from the whole device, which is rotated when measurement running. The measurement is performed with the Measurement Antenna in both horizontal and vertical polarization planes.

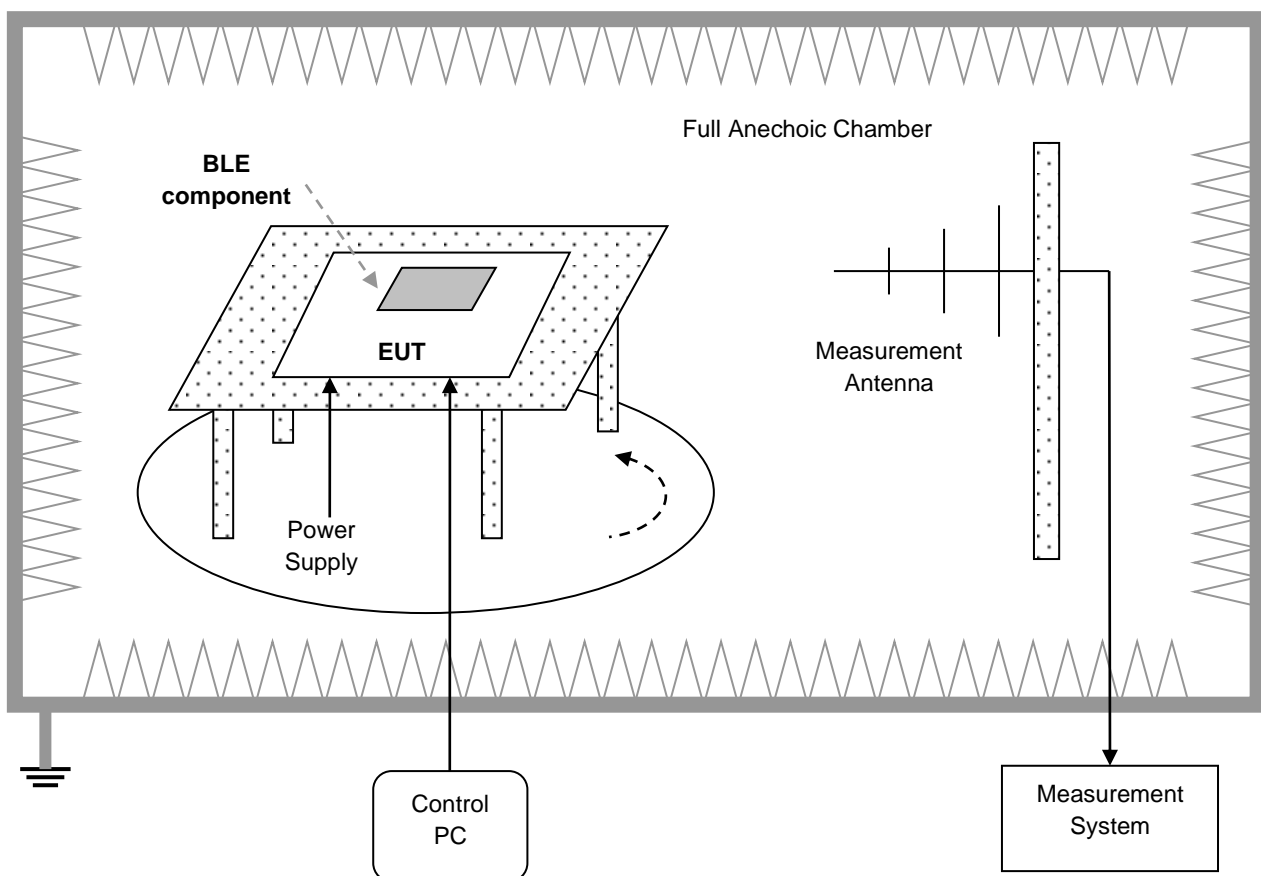

4.5 Test Conditions

Test Case	Test Conditions	
	Configuration	Description
Equivalent Isotropic Radiated Power (EIRP)	Measurement Method	Conducted
	Power Level	Highest
	Test Conditions	NTNV, LTNV, HTNV
	Smart Antenna Systems	Ant 1
	Test Modes	BLE
	Test Frequency	L, M, H
Maximum EIRP Spectral Density	Measurement Method	Conducted, Option 1
	Power Level	Highest
	Test Conditions	NTNV
	Smart Antenna Systems	Ant 1
	Test Modes	BLE
	TX ON time (>10 μ s)	Fulfilled
	Test Frequency	L, M, H
Occupied Channel Bandwidth	Measurement Method	Conducted, Option 1
	Test Conditions	NTNV
	Smart Antenna Systems	Ant 1
	Test Modes	BLE
	Transmitter Mode	Operating
	Test Frequency	L, H
Transmitter unwanted emissions in the out-of-band domain	Measurement Method	Conducted, Option 1
	Test Conditions	NTNV
	Smart Antenna Systems	Ant 1
	Test Modes	BLE

Test Case	Test Conditions	
	Configuration	Description
	Test Frequency	L, H
Transmitter unwanted emissions in the spurious domain	Measurement Method	Radiated
	Test Conditions	NTNV
	Smart Antenna Systems	Ant 1
	Test Modes	BLE
	Transmitter Mode	Operating
	Test Frequency	L, H
Receiver Spurious Emissions	Measurement Method	Radiated
	Test Conditions	NTNV
	Smart Antenna Systems	Ant 1
	Test Modes	BLE
	Receiver Mode	Continues Receiving
	Test Frequency	L, H
Receiver Blocking	Measurement Method	Conducted, Option 1
	Power Level	Highest
	Test Conditions	NTNV
	Smart Antenna Systems	Ant 1
	Test Modes	BLE
	Transmitter Mode	Operating
	Test Frequency	L, H

5 Test Results

No.	Test Item	Test Result
1	4.3.2.2 RF output power	Appendix A
2	4.3.2.3 Power Spectral Density	Appendix B
3	4.3.2.4 Duty Cycle, Tx-sequence, Tx-gap	N/A
4	4.3.2.5 Medium Utilisation (MU) factor	N/A
5	4.3.2.6 Adaptivity	N/A
6	4.3.2.7 Occupied Channel Bandwidth	Appendix C
7	4.3.2.8 Transmitter unwanted emissions in the out-of-band domain	Appendix D
8	4.3.2.9 Transmitter unwanted emissions in the spurious domain_Radiated	Appendix E
9	4.3.2.9 Transmitter unwanted emissions in the spurious domain_Conducted	N/A
10	4.3.2.10 Receiver spurious emissions_Radiated	Appendix F
11	4.3.2.10 Receiver spurious emissions_Conducted	N/A
12	4.3.2.11 Receiver Blocking	Appendix G

6 Test Requirements

6.1 RF output power

The equivalent isotropic radiated power (as EIRP) shall be equal to or less than -10 dBW (= 20 dBm). This limit shall apply for any combination of power level and intended antenna assembly.

6.2 Maximum EIRP Spectral Density

For wide band modulations other than FHSS (e.g. DSSS, OFDM, etc.), the maximum e.i.r.p. spectral density (as PD) is limited to 10 mW per MHz (= 10 dBm/MHz).

6.3 Adaptivity

The equipment used Non-LBT based Detect and Avoid mechanism shall comply with the requirements defined in clause 4.3.2.6.2.2

LBT based Detect and Avoid mechanism: This mechanism defines 2 types of adaptive equipment using wide band modulations and that uses an LBT based Detect and Avoid mechanism: Frame Based Equipment and Load Based Equipment. The kind of the equipment shall comply with the requirements defined in clause 4.3.2.6.3.2

Short Control Signalling Transmissions: The transmissions used by adaptive equipment to send control signals (e.g. ACK/NACK signals, etc.) without sensing the operating channel for the presence of other signals. Adaptive equipment may or may not have Short Control Signalling Transmissions. If implemented, the limit of Short Control Signalling Transmissions of adaptive equipment using wide band modulations shall have a maximum duty cycle of 10 % within an observation period of 50 ms.

6.4 Occupied Channel Bandwidth

The Occupied Channel Bandwidth shall fall completely within the band given in table 1.

In addition, for non-adaptive equipment using wide band modulations other than FHSS and with e.i.r.p. greater than 10 dBm, the occupied channel bandwidth shall be less than 20 MHz.

Table 1: Service frequency bands

	Service frequency bands
Transmit	2 400 MHz to 2 483,5 MHz
Receive	2 400 MHz to 2 483,5 MHz

6.5 Transmitter unwanted emissions in the out-of-band domain

The transmitter unwanted emissions in the out-of-band domain but outside the allocated band, shall not exceed the values provided by the mask in below figure.

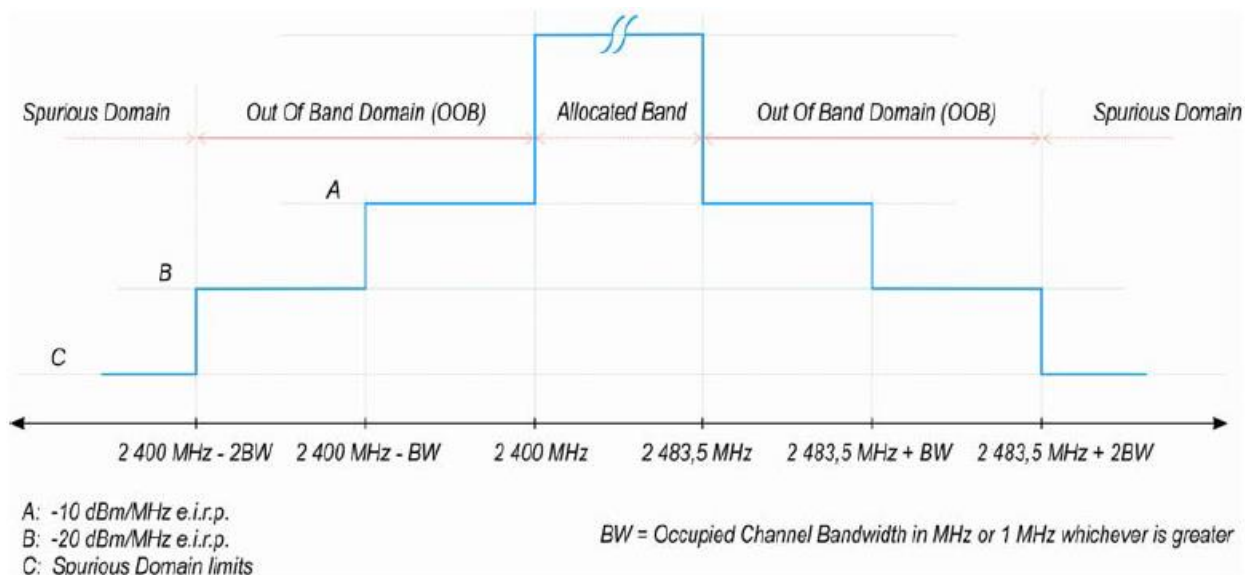

NOTE: Within the 2 400 MHz to 2 483.5 MHz band, the Out-of-band emissions are fulfilled by compliance with the Occupied Channel Bandwidth requirement in clause 4.3.2.7.

6.6 Transmitter Spurious Emissions

The spurious emissions of the transmitter shall not exceed the values in following tables in the indicated bands.

Frequency Range	Limit When Operating	Limit When in Standby
30MHz to 47MHz	-36dBm	-57 dBm
47MHz-74MHz	-54dBm	-57 dBm
74MHz-87.5MHz	-36dBm	-57 dBm
87.5MHz-118MHz	-54dBm	-57 dBm
118MHz-174MHz	-36dBm	-57 dBm
174MHz-230MHz	-54dBm	-57 dBm
230MHz-470MHz	-36dBm	-57 dBm
470MHz-694MHz	-54dBm	-57 dBm
694MHz-1GHz	-36dBm	-57 dBm
Above 1GHz to 12.75GHz	-30dBm	-47 dBm

NOTE: The above limit values apply to narrowband emissions, e.g. as caused by local oscillator leakage. The measurement bandwidth for such emissions may be as small as necessary to achieve a reliable measurement result.

6.7 Receiver Spurious Emissions

The spurious emissions of the receiver shall not exceed the values in following tables in the indicated bands.

Frequency Range	Limit
30 MHz to 1 GHz	-57 dBm
1 GHz to 12.75 GHz	-47 dBm

Note: The above limit values apply to narrowband emissions, e.g. as caused by local oscillator leakage. The measurement bandwidth for such emissions may be as small as necessary to achieve a reliable measurement result.

6.8 Receiver Blocking

While maintaining the minimum performance criteria as defined in clause 4.3.2.11.3, the blocking levels at specified frequency offsets shall be equal to or greater than the limits defined for the applicable receiver category provided in table 14, table 15 or table 16.

Table 14 contains the Receiver Blocking parameters for Receiver Category 1 equipment.

Table 14: Receiver Blocking parameters for Receiver Category 1 equipment

Wanted signal mean power from companion device (dBm) (see notes 1 and 4)	Blocking signal frequency (MHz)	Blocking signal power (dBm) (see note 4)	Type of blocking signal
$(-133 \text{ dBm} + 10 \times \log_{10}(\text{OCBW}))$ or -68 dBm whichever is less (see note 2)	2 380 2 504	-34	CW
$(-139 \text{ dBm} + 10 \times \log_{10}(\text{OCBW}))$ or -74 dBm whichever is less (see note 3)	2 300 2 330 2 360 2 524 2 584 2 674		
NOTE 1: OCBW is in Hz.			
NOTE 2: In case of radiated measurements using a companion device and the level of the wanted signal from the companion device cannot be determined, a relative test may be performed using a wanted signal up to $P_{\text{min}} + 26 \text{ dB}$ where P_{min} is the minimum level of wanted signal required to meet the minimum performance criteria as defined in clause 4.3.1.12.3 in the absence of any blocking signal.			
NOTE 3: In case of radiated measurements using a companion device and the level of the wanted signal from the companion device cannot be determined, a relative test may be performed using a wanted signal up to $P_{\text{min}} + 20 \text{ dB}$ where P_{min} is the minimum level of wanted signal required to meet the minimum performance criteria as defined in clause 4.3.1.12.3 in the absence of any blocking signal.			
NOTE 4: The level specified is the level at the UUT receiver input assuming a 0 dBi antenna assembly gain. In case of conducted measurements, this level has to be corrected for the (in-band) antenna assembly gain (G). In case of radiated measurements, this level is equivalent to a power flux density (PFD) in front of the UUT antenna with the UUT being configured/positioned as recorded in clause 5.4.3.2.2.			

Table 15 contains the Receiver Blocking parameters for Receiver Category 2 equipment.

Table 15: Receiver Blocking parameters receiver Category 2 equipment

Wanted signal mean power from companion device (dBm) (see notes 1 and 3)	Blocking signal frequency (MHz)	Blocking signal power (dBm) (see note 3)	Type of blocking signal
$(-139 \text{ dBm} + 10 \times \log_{10}(\text{OCBW}) + 10 \text{ dB})$ or $(-74 \text{ dBm} + 10 \text{ dB})$ whichever is less (see note 2)	2 380 2 504 2 300 2 584	-34	CW
NOTE 1: OCBW is in Hz. NOTE 2: In case of radiated measurements using a companion device and the level of the wanted signal from the companion device cannot be determined, a relative test may be performed using a wanted signal up to $P_{\min} + 26 \text{ dB}$ where P_{\min} is the minimum level of wanted signal required to meet the minimum performance criteria as defined in clause 4.3.1.12.3 in the absence of any blocking signal. NOTE 3: The level specified is the level at the UUT receiver input assuming a 0 dBi antenna assembly gain. In case of conducted measurements, this level has to be corrected for the (in-band) antenna assembly gain (G). In case of radiated measurements, this level is equivalent to a power flux density (PFD) in front of the UUT antenna with the UUT being configured/positioned as recorded in clause 5.4.3.2.2.			

Table 16 contains the Receiver Blocking parameters for Receiver Category 3 equipment.

Table 16: Receiver Blocking parameters receiver Category 3 equipment

Wanted signal mean power from companion device (dBm) (see notes 1 and 3)	Blocking signal frequency (MHz)	Blocking signal power (dBm) (see note 3)	Type of blocking signal
$(-139 \text{ dBm} + 10 \times \log_{10}(\text{OCBW}) + 20 \text{ dB})$ or $(-74 \text{ dBm} + 20 \text{ dB})$ whichever is less (see note 2)	2 380 2 504 2 300 2 584	-34	CW
NOTE 1: OCBW is in Hz. NOTE 2: In case of radiated measurements using a companion device and the level of the wanted signal from the companion device cannot be determined, a relative test may be performed using a wanted signal up to $P_{\min} + 30 \text{ dB}$ where P_{\min} is the minimum level of wanted signal required to meet the minimum performance criteria as defined in clause 4.3.1.12.3 in the absence of any blocking signal. NOTE 3: The level specified is the level at the UUT receiver input assuming a 0 dBi antenna assembly gain. In case of conducted measurements, this level has to be corrected for the (in-band) antenna assembly gain (G). In case of radiated measurements, this level is equivalent to a power flux density (PFD) in front of the UUT antenna with the UUT being configured/positioned as recorded in clause 5.4.3.2.2.			

6.9 Estimation of Exposure of Human to Electromagnetic Fields

The product has an operation frequency of [2402-2480MHz], and the maximum transmitted power is 6.40dBm (4.37mW).

According with EN 50663:2017 clause 6, EN 62479:2010,4.1 and clause 6, Equipment complying with the requirements for the general public is deemed to comply with the requirements for workers without further testing if it can be demonstrated using routes B, C or D that the available antenna power and/or the average total radiated power is less than or equal to the values of Pmax. The peak output power of the product is 4.37mW; it is less than the limit 20mW which list in the table 1, so the equipment complies with EMF basic restrictions in EN 50663:2017 and EN 62479:2010.

7 Main Test Instruments

List of Test Instruments

Test Site1

	DESCRIPTION	MANUFACTURER	MODEL NO.	SERIAL NO.	CAL. DATE	CAL. DUE DATE
C	Wideband Radio Communication Tester	R&S	CMW500	S2110416b-YQ-EMC	2021-11-26	2022-11-25
	Vector signal generator	Agilent	N5182A	S2110417b-YQ-EMC	2021-11-28	2022-11-27
	RF automatic control unit	MWRfTest	MW100-RFCB	S2110418b-YQ-EMC	2021-11-28	2022-11-27
	Temperature Chamber	Kushan Bositong	BST-TC-415T	S1908307-YQ-EMC	2021-12-1	2022-11-30
	Signal Analyzer	R & S	FSV40	S1503003-YQ-EMC	2021-8-2	2022-8-1
RE	EMI test receiver	R & S	ESR3	S1503109-YQ-EMC	2021-8-2	2022-8-1
	Signal Analyzer	R & S	FSV40	S1503003-YQ-EMC	2021-8-2	2022-8-1
	Trilog super broadband test antenna	SCHWARZBECK	VULB 9168	S1808296-YQ-EMC	2021-9-23	2024-9-22
	Horn Antenna	R & S	HF907	S1503009-YQ-EMC	2021-4-13	2024-4-12
	Pre-amplifier	R & S	SCU-18D	S1503012-YQ-EMC	2021-8-2	2022-8-1
	3 meter semi-anechoic chamber	TDK	3m	S1503231-YQ-EMC	2021-5-8	2024-5-7
Measurement Software Information						
Test Item	Software	Manufacturer	Version			
C	MTS 8310	MWRfTest	2.0.0.0			
RE	EMC 32	R & S	V10.50.40			

Conducted RF tests –C

- RF output power
- Power Spectral Density
- Adaptivity & Receiver Blocking
- Occupied Channel Bandwidth
- Transmitter unwanted emissions OOB

Radiated RF tests- RE

- Radiated unwanted emissions spurious TX
- Radiated unwanted emissions spurious RX

8 System Measurement Uncertainty

For the test methods, according to the harmonized standard and conformance testing standard, the measurement uncertainty figures shall be calculated in accordance with TR 100 028 and shall correspond to an expansion factor (coverage factor) $k = 1.96$ (which provides a confidence level of 95 % in the case where the distributions characterizing the actual measurement uncertainties are normal (Gaussian)).

System Measurement Uncertainty	
Test Items	Extended Uncertainty
Uncertainty for Radiated Spurious Emission 30MHz-1000MHz	$\pm 3.49\text{dB}$ (Horizontal), $\pm 3.50\text{dB}$ (Vertical)
Uncertainty for Conducted RF test	Power level test involved: 2.04dB Frequency test involved: 1.1×10^{-7}

9 Appendix A: RF output power

NOTE 1: In this Appendix, EIRP [dBm] = A [dBm] + G [dBi]+Y(dBi). Where, A = RMS Power, G = Antenna Gain and Y=beamforming (if any). The Jumper Cable Loss (JCL) (if applicable) and Test Path Loss (TPL) were calculated into A.

NOTE 2: For measurements on smart antenna systems (devices with multiple transmit chains), the test is performed at each chain, and then combined into a final result. The result is the calculated linear sum of each chain (as Ant sum).

(1) Common Parameter

Test Mode	Power Level Setting defined by Manufacturer	X [%]	G [dBi]
BLE	5dBm	100	2.08

(2) Test Result

Temperature (°C)	Mode	Channel No.	Frequency (MHz)	E.I.R.P (dBm)	Limit (dBm)
NTNV	BLE (1Mbps)	11	2402	6.09	20.00
		18	2440	6.31	20.00
		26	2480	6.14	20.00
LTVN	BLE (1Mbps)	11	2402	6.82	20.00
		18	2440	7.08	20.00
		26	2480	6.86	20.00
HTNV	BLE (1Mbps)	11	2402	5.53	20.00
		18	2440	5.76	20.00
		26	2480	5.55	20.00
NTNV	BLE (2Mbps)	11	2402	6.15	20.00
		18	2440	6.35	20.00
		26	2480	6.18	20.00
LTVN	BLE (2Mbps)	11	2402	6.91	20.00
		18	2440	7.11	20.00
		26	2480	6.92	20.00
HTNV	BLE (2Mbps)	11	2402	5.63	20.00
		18	2440	5.79	20.00
		26	2480	5.62	20.00



China

Temperature (°C)	Mode	Channel No.	Frequency (MHz)	E.I.R.P (dBm)	Limit (dBm)
NTNV	BLE (500Kbps)	11	2402	6.20	20.00
		18	2440	6.40	20.00
		26	2480	6.23	20.00
LTVN	BLE (500Kbps)	11	2402	6.95	20.00
		18	2440	7.16	20.00
		26	2480	6.96	20.00
HTNV	BLE (500Kbps)	11	2402	5.67	20.00
		18	2440	5.85	20.00
		26	2480	5.67	20.00
NTNV	BLE (125Kbps)	11	2402	6.22	20.00
		18	2440	6.40	20.00
		26	2480	6.25	20.00
LTVN	BLE (125Kbps)	11	2402	6.96	20.00
		18	2440	7.16	20.00
		26	2480	6.97	20.00
HTNV	BLE (125Kbps)	11	2402	5.67	20.00
		18	2440	5.83	20.00
		26	2480	5.68	20.00

10 Appendix B: Maximum EIRP Spectral Density

NOTE 1: In this Appendix, PD [dBm/MHz] = D [dBm/MHz] + G [dBi]+Y(dBi). Where, D = Spectral Power Density, G = Antenna Gain and Y=Beamforming Gain(if any). The Jumper Cable Loss (JCL) (if applicable) and Test Path Loss (TPL) were calculated into D.

NOTE 2: For measurements on smart antenna systems (devices with multiple transmit chains), the test is performed at each chain, and then combined into a final result. The result is the calculated linear sum of each chain (as Ant sum).

(1) Common Parameter

Test Mode	Power Level Setting defined by Manufacturer	X [%]	G [dBi]
BLE	5dBm	100	2.08

(2) Test Result

Test Mode	RF Ch.	Ant.	PD [dBm/MHz]	Limit [dBm/MHz]	Verdict
BLE(1Mbps)	L	Ant 1	6.02	< 10	PASS
	M	Ant 1	6.24	< 10	PASS
	H	Ant 1	6.07	< 10	PASS
BLE(2Mbps)	L	Ant 1	4.81	< 10	PASS
	M	Ant 1	5.01	< 10	PASS
	H	Ant 1	4.85	< 10	PASS
BLE (500Kbps)	L	Ant 1	6.08	< 10	PASS
	M	Ant 1	6.28	< 10	PASS
	H	Ant 1	6.11	< 10	PASS
BLE (125Kbps)	L	Ant 1	6.11	< 10	PASS
	M	Ant 1	6.30	< 10	PASS
	H	Ant 1	6.14	< 10	PASS

11 Appendix C: Occupied Channel Bandwidth

Test mode	Channel	Frequency (MHz)	Occupied Channel Bandwidth (MHz)	Frequency (MHz)		Limit
				FL(MHz)	FH(MHz)	
BLE(1Mbps)	0	2402	1.071	2401.477	--	FL>2400MHz and FH<2483.5MHz
	39	2480	1.067	--	2479.479	
BLE(2Mbps)	0	2402	2.170	2400.929	--	FL>2400MHz and FH<2483.5MHz
	39	2480	2.182	--	2478.921	
BLE (500Kbps)	0	2402	1.135	2401.443	--	FL>2400MHz and FH<2483.5MHz
	39	2480	1.127	--	2480.573	
BLE (125Kbps)	0	2402	1.115	2401.453	--	FL>2400MHz and FH<2483.5MHz
	39	2480	1.115	--	2480.567	



12 Appendix D: Transmitter unwanted emissions in the out-of-band domain

Test mode	Test condition:	Test frequency (MHz)	Test segment (MHz)	Max. Reading (dBm/MHz)	Limit (dBm/MHz)
BLE (1Mbps)	NTNV	2402	2400-BW to 2400	-40.21	-10
			2400-2BW to 2400-BW	-43.19	-20
		2480	2483.5 to 2483.5+BW	-44.07	-10
			2483.5+BW to 2483.5+2BW	-45.60	-20
BLE (2Mbps)	NTNV	2402	2400-BW to 2400	-27.57	-10
			2400-2BW to 2400-BW	-42.66	-20
		2480	2483.5 to 2483.5+BW	-41.26	-10
			2483.5+BW to 2483.5+2BW	-44.68	-20
BLE (500Kbps)	NTNV	2402	2400-BW to 2400	-41.03	-10
			2400-2BW to 2400-BW	-43.56	-20
		2480	2483.5 to 2483.5+BW	-44.23	-10
			2483.5+BW to 2483.5+2BW	-45.67	-20
BLE (125Kbps)	NTNV	2402	2400-BW to 2400	-41.02	-10
			2400-2BW to 2400-BW	-43.56	-20
		2480	2483.5 to 2483.5+BW	-44.23	-10
			2483.5+BW to 2483.5+2BW	-45.66	-20



13 Appendix E: Transmitter Spurious Emissions – Radiated Mode

NOTE 1: The whole testing range is from “30 MHz to 12.75 GHz” is divided into 2 parts according to the test site settings, which are:

- Part 1: Test range of “30 MHz to 1GHz”,
- Part 2: Test range of “1 GHz to 12.75 GHz”.

NOTE 2: In this Appendix, X = Duty Cycle and G = Antenna Gain. The test path transducer was directly calculated into results for each test range.

(1) Common Parameter

Test Mode	Power Level Setting defined by Manufacturer	X [%]	G [dBi]
BLE	5dBm	100	2.08

(2) Test Result

Note: The test results for testing range of “30 MHz to 12.75 GHz” showed as below is **the WORST case for all Test Modes and Channels**. The detected values which are noise floor or below the limit 20dB will not be recorded.

Transmitting spurious emission test result as below:

BLE 1Mbps					
Channel 0 (2402MHz)					
Frequency (MHz)	Maximum Emission Observed(dBm)	Limit (dBm)	Margin (dB)	Detector	Polarization
7206.5	-43.14	-30.0	13.14	Peak	Horizontal
7206.5	-50.60	-30.0	20.6	Peak	Vertical
Channel 39 (2480MHz)					
Frequency (MHz)	Maximum Emission Observed(dBm)	Limit (dBm)	Margin (dB)	Detector	Polarization
7439.7	-42.41	-30.0	12.41	Peak	Horizontal
7439.7	-48.15	-30.0	18.15	Peak	Vertical

BLE 2Mbps					
Channel 0 (2402MHz)					
Frequency (MHz)	Maximum Emission Observed(dBm)	Limit (dBm)	Margin (dB)	Detector	Polarization
7206.5	-43.24	-30.0	13.24	Peak	Horizontal
7206.5	-51.52	-30.0	21.52	Peak	Vertical
7206.5					
Frequency (MHz)	Maximum Emission Observed(dBm)	Limit (dBm)	Margin (dB)	Detector	Polarization
7439.7	-44.69	-30.0	14.69	Peak	Horizontal
7439.7	-49.11	-30.0	19.11	Peak	Vertical

BLE 500Kbps					
Channel 0 (2402MHz)					
Frequency (MHz)	Maximum Emission Observed(dBm)	Limit (dBm)	Margin (dB)	Detector	Polarization
7206.5	-42.84	-30.0	12.84	Peak	Horizontal
7206.5	-49.60	-30.0	19.60	Peak	Vertical
Channel 39 (2480MHz)					
Frequency (MHz)	Maximum Emission Observed(dBm)	Limit (dBm)	Margin (dB)	Detector	Polarization
7439.7	-41.92	-30.0	11.92	Peak	Horizontal
7439.7	-48.69	-30.0	18.69	Peak	Vertical

BLE 125Kbps					
Channel 0 (2402MHz)					
Frequency (MHz)	Maximum Emission Observed(dBm)	Limit (dBm)	Margin (dB)	Detector	Polarization
7206.5	-40.88	-30.0	10.88	Peak	Horizontal
7206.5	-49.41	-30.0	19.41	Peak	Vertical
Channel 39 (2480MHz)					
Frequency (MHz)	Maximum Emission Observed(dBm)	Limit (dBm)	Margin (dB)	Detector	Polarization
7439.7	-42.02	-30.0	12.02	Peak	Horizontal
7439.7	-48.77	-30.0	18.77	Peak	Vertical

The worst case of Radiated Emission below 1GHz:

Site: 3 meter chamber	Time: 2022/03/09 - 16:48
Limit: EN 300 328_RE (3m)	Engineer: Wang Yiquan
Probe: VULB9168	Polarity: Horizontal
UT: Led Lamp, Model no: 9290034987	Power: AC 230V,50Hz
Note: Transmit by at channel 2440MHz.125Kbps (worst case).	

Limit and Margin

Frequency (MHz)	RMS (dBm)	Meas. Time (ms)	Bandwidth (kHz)	Height (cm)	Pol	Azimuth (deg)	Corr. (dB)	Margin - RMS (dB)	Limit - RMS (dBm)
70.36	-62.6	1000.0	120.000	149.9	H	195.0	-79.2	8.6	-54.0
101.11	-65.8	1000.0	120.000	149.9	H	359.0	-76.8	11.8	-54.0
129.38	-66.2	1000.0	120.000	149.9	H	243.0	-78.9	30.2	-36.0
238.19	-66.9	1000.0	120.000	149.9	H	123.0	-77.8	30.9	-36.0
335.00	-65.0	1000.0	120.000	149.9	H	54.0	-74.7	29.0	-36.0
567.42	-64.6	1000.0	120.000	149.9	H	317.0	-71.2	10.6	-54.0

Site: 3 meter chamber	Time: 2022/03/09 - 17:18
Limit: EN 300 328_RE (3m)	Engineer: Wang Yiquan
Probe: VULB9168	Polarity: Vertical
UT: Led Lamp, Model no: 9290034987	Power: AC 230V,50Hz
Note: Transmit by at channel 2440MHz.125Kbps (worst case).	

Limit and Margin

Frequency (MHz)	RMS (dBm)	Meas. Time (ms)	Bandwidth (kHz)	Height (cm)	Pol	Azimuth (deg)	Corr. (dB)	Margin - RMS (dB)	Limit - RMS (dBm)
47.2	-67.6	1000.0	120.000	149.9	V	195.0	-79.2	13.6	-54.0
55.4	-65.1	1000.0	120.000	149.9	V	359.0	-76.8	11.1	-54.0
176.5	-63.2	1000.0	120.000	149.9	V	243.0	-78.9	9.2	-54.0
316.2	-63.9	1000.0	120.000	149.9	V	123.0	-77.8	27.9	-36.0
578.1	-60.5	1000.0	120.000	149.9	V	54.0	-74.7	6.5	-54.0
879.2	-64.2	1000.0	120.000	149.9	V	317.0	-71.2	28.2	-36.0



14 Appendix F: Receiver Spurious Emissions-Radiated Mode

NOTE 1: The whole testing range is from “30 MHz to 12.75 GHz” is divided into 2 parts according to the test site settings, which are:

- Part 1: Test range of “30 MHz to 1 GHz”,
- Part 2: Test range of “1 GHz to 12.75 GHz”.

NOTE 2: In this Appendix, X = Duty Cycle and G = Antenna Gain. The test path transducer was directly calculated into results for each test range.

(1) Common Parameter

Test Mode	Power Level Setting defined by Manufacturer	X [%]	G [dBi]
BLE	5dBm	100	2.08

(2) Test Result

NOTE: Only test results and plots under the WORST case are reported.

BLE:125Kbps

Invested Frequency Range(MHz)	Frequency(MHz)	Maximum Emission	DETECTOR	Limit (dBm)	Margin (dB)	Polarization
		Observed(dBm)				
30-1000	538.42	-64.24	PK	-57.00	7.24	H
1000-12750	--	<-70.0	PK	-47.00	>20	H
30-1000	98.59	-68.21	PK	-57.00	11.21	V
1000-12750	--	<-70.0	PK	-47.00	>20	V

Remark: The detected values which are noise floor or below the limit 20dB will not be recorded.

15 Appendix G: Receiver Blocking

Test result:

BLE:1Mbps

Test Condition	Test Mode	Test Channel	Ant	Wanted signal Level[dBm]	Freq [MHz]	CW Level [dBm]	PER [%]	Limit [%]	Verdict
NTNV	Receiving	2402	Ant1	-68.70	2380	-34	0.50	<=10	PASS
NTNV	Receiving	2402	Ant1	-68.70	2300	-34	0.60	<=10	PASS
NTNV	Receiving	2480	Ant1	-68.70	2504	-34	1.20	<=10	PASS
NTNV	Receiving	2480	Ant1	-68.70	2584	-34	1.20	<=10	PASS

BLE:2Mbps

Test Condition	Test Mode	Test Channel	Ant	Wanted signal Level[dBm]	Freq [MHz]	CW Level [dBm]	PER [%]	Limit [%]	Verdict
NTNV	Receiving	2402	Ant1	-65.61	2380	-34	1.20	<=10	PASS
NTNV	Receiving	2402	Ant1	-65.61	2300	-34	0.90	<=10	PASS
NTNV	Receiving	2480	Ant1	-65.64	2504	-34	1.30	<=10	PASS
NTNV	Receiving	2480	Ant1	-65.64	2584	-34	1.30	<=10	PASS

BLE:500Kbps

Test Condition	Test Mode	Test Channel	Ant	Wanted signal Level[dBm]	Freq [MHz]	CW Level [dBm]	PER [%]	Limit [%]	Verdict
NTNV	Receiving	2402	Ant1	-68.53	2380	-34	0.70	<=10	PASS
NTNV	Receiving	2402	Ant1	-68.53	2300	-34	0.60	<=10	PASS
NTNV	Receiving	2480	Ant1	-68.54	2504	-34	1.10	<=10	PASS
NTNV	Receiving	2480	Ant1	-68.54	2584	-34	1.20	<=10	PASS

BLE:125Kbps

Test Condition	Test Mode	Test Channel	Ant	Wanted signal Level[dBm]	Freq [MHz]	CW Level [dBm]	PER [%]	Limit [%]	Verdict
NTNV	Receiving	2402	Ant1	-68.45	2380	-34	0.80	<=10	PASS
NTNV	Receiving	2402	Ant1	-68.45	2300	-34	0.90	<=10	PASS
NTNV	Receiving	2480	Ant1	-68.48	2504	-34	1.00	<=10	PASS
NTNV	Receiving	2480	Ant1	-68.48	2584	-34	0.80	<=10	PASS

16 Appendix H: Test Setup Photos

Radiated Emission (30MHz-1GHz)



Radiated Emission (1GHz-12.75GHz)



17 Appendix I: Photographs of EUT

Model: 9290034987

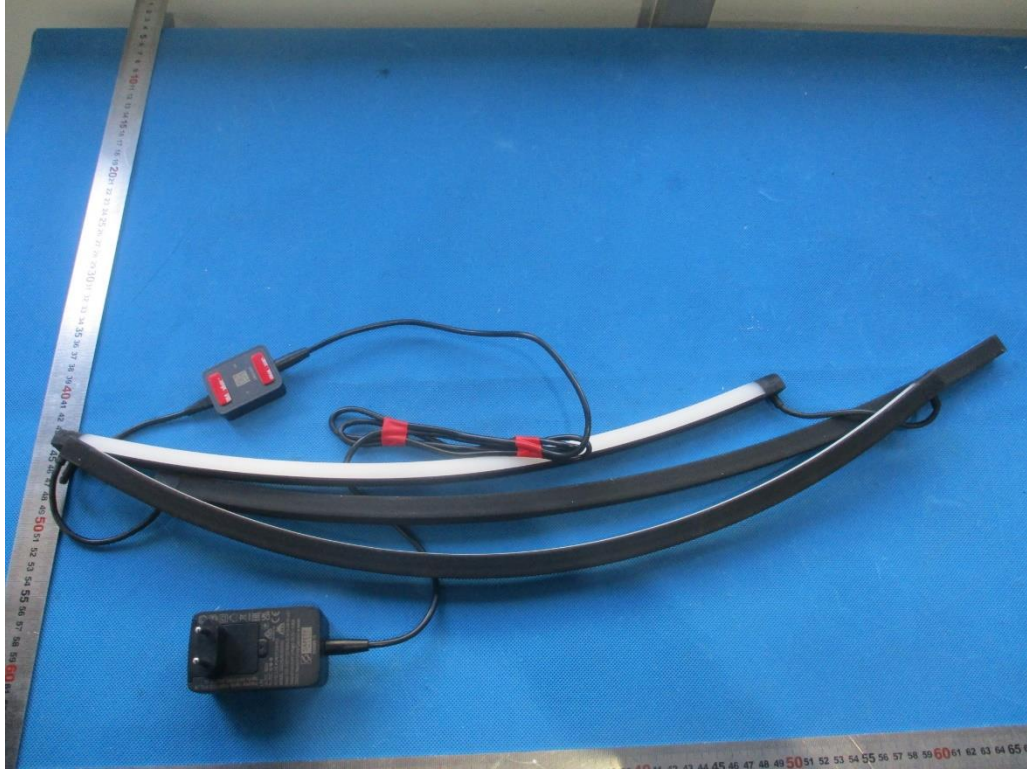

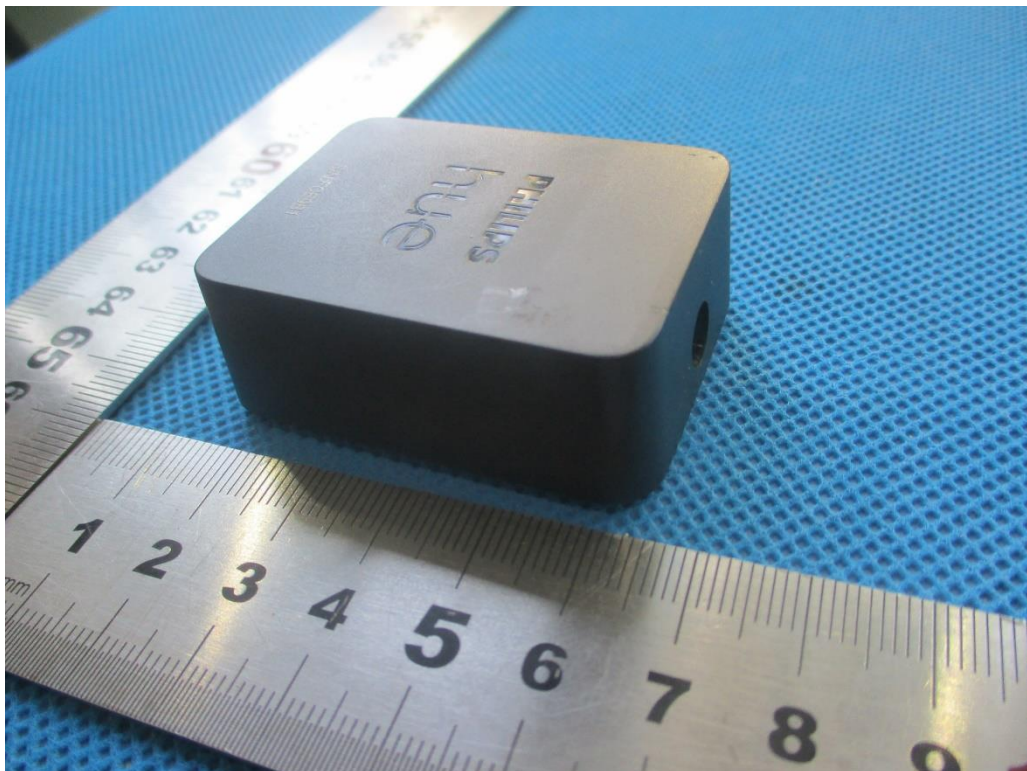

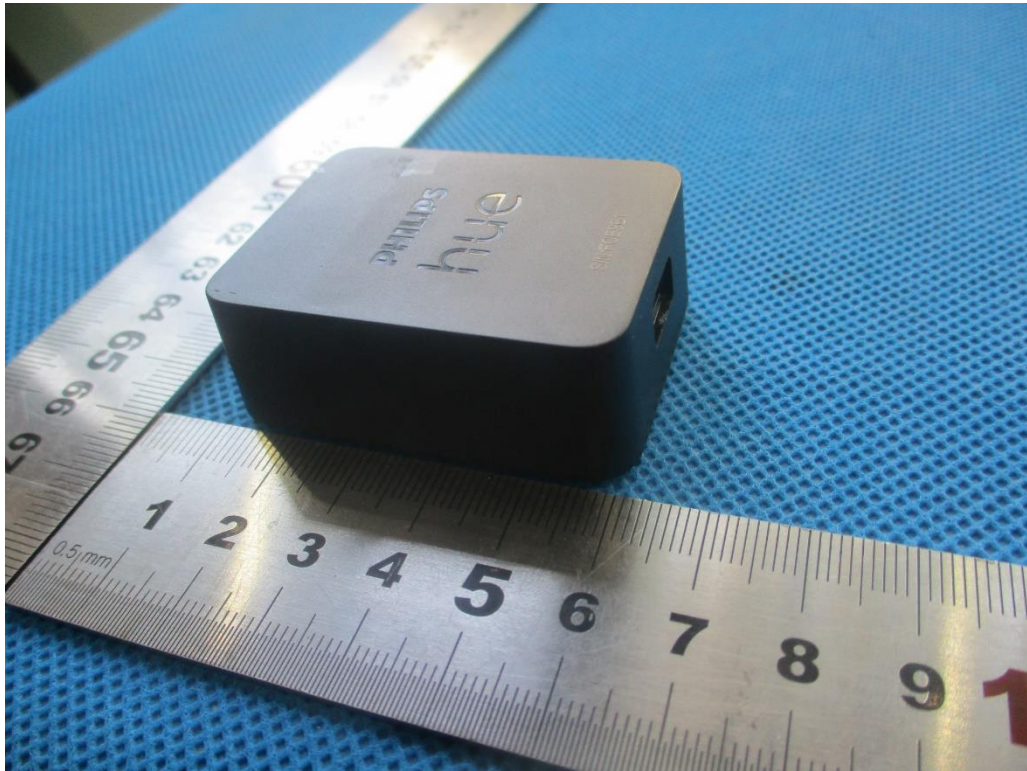

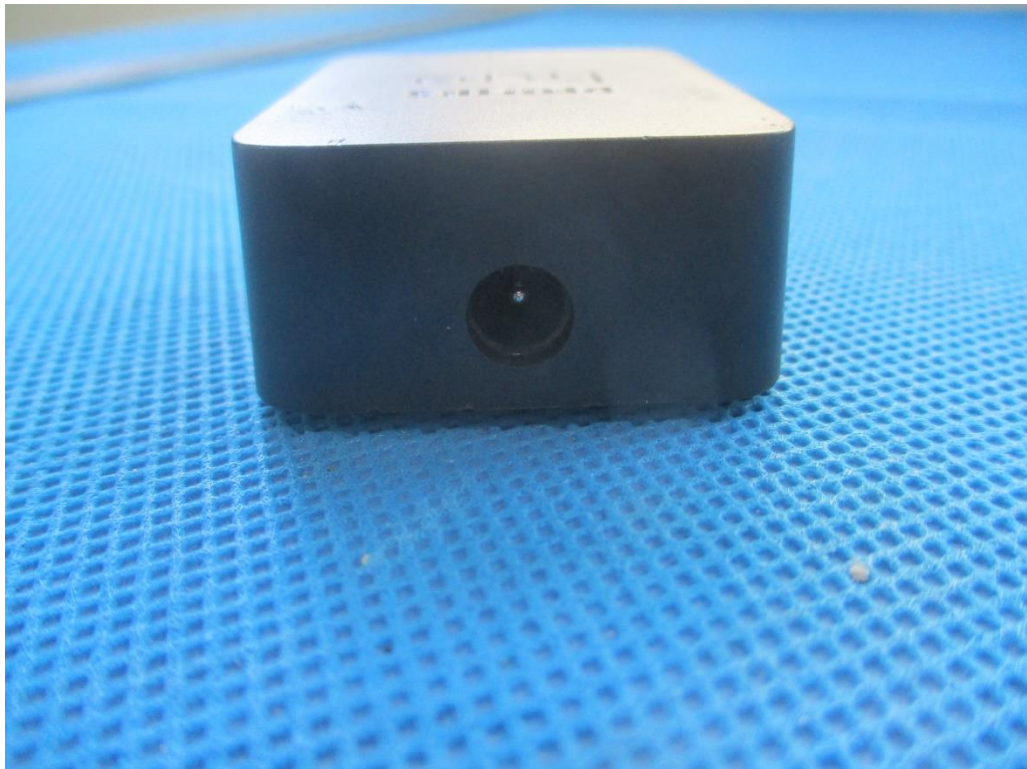

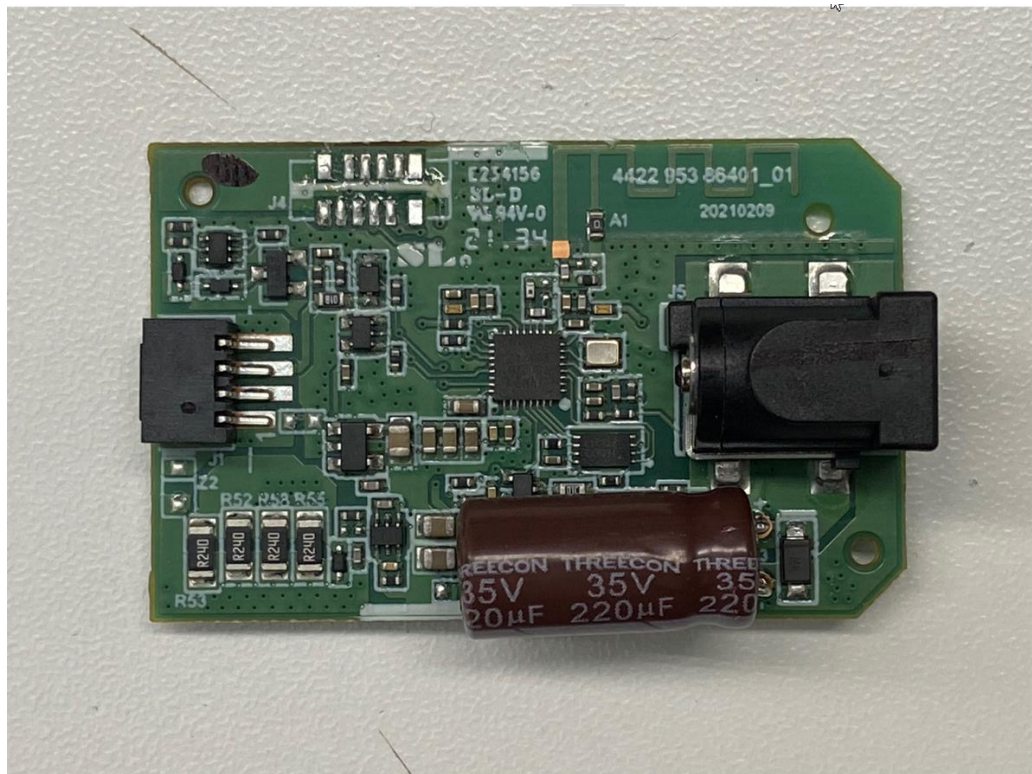

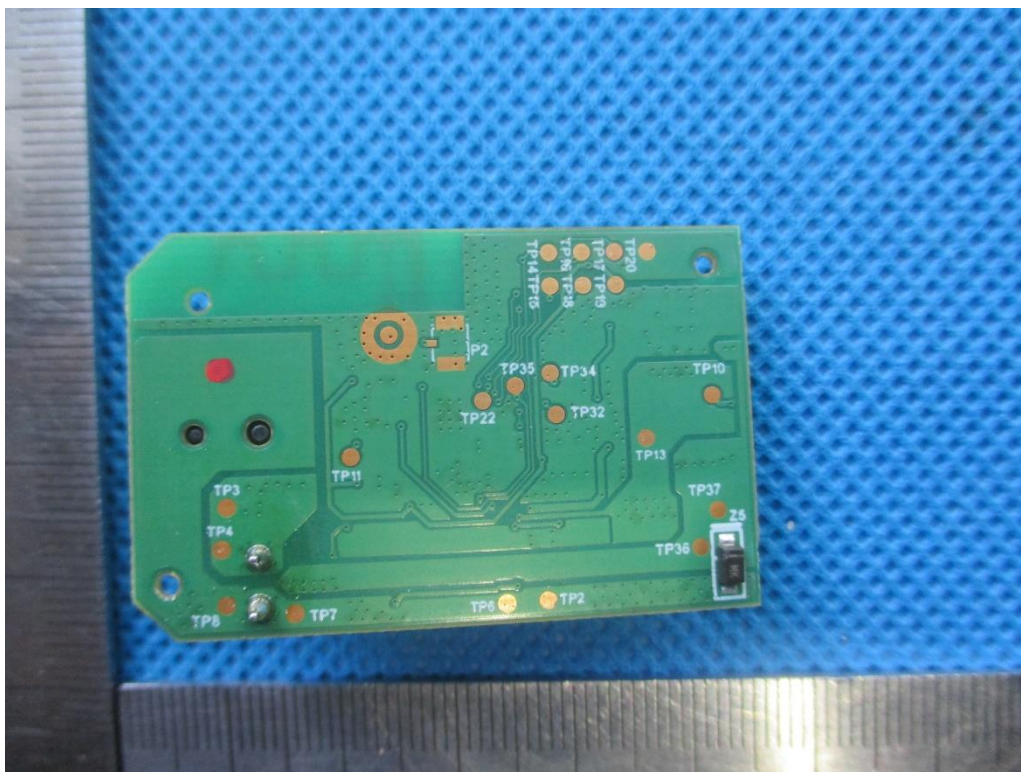

THE END

RF - TEST REPORT

Report Number : **709502203711-01C** Date of Issue: **July 20, 2022**

Model : 9290034985,9290034986,9290034987

Product Type : **Rope light**

Applicant : Signify (China) Investment Co., Ltd.

Address : Building No. 9, Lane 888, Tianlin Road

Minhang 200233 Shanghai PEOPLE'S REPUBLIC OF CHINA

Manufacturer : Signify (China) Investment Co., Ltd.

Address : Building No. 9, Lane 888, Tianlin Road

Minhang 200233 Shanghai PEOPLE'S REPUBLIC OF CHINA

Test Result : **Positive** **Negative**

Total pages including Appendices : **38**



TÜV SÜD Certification and Testing (China) Co., Ltd. – Shanghai Branch is a subcontractor to TÜV SÜD Product Service GmbH according to the principles outlined in ISO 17025.

TÜV SÜD Certification and Testing (China) Co., Ltd. – Shanghai Branch reports apply only to the specific samples tested under stated test conditions. Construction of the actual test samples has been documented. It is the manufacturer's responsibility to assure that additional production units of this model are manufactured with identical electrical and mechanical components. The manufacturer/importer is responsible to the Competent Authorities in Europe for any modifications made to the production units which result in non-compliance to the relevant regulations. TÜV SÜD Certification and Testing (China) Co., Ltd. – Shanghai Branch shall have no liability for any deductions, inferences or generalizations drawn by the client or others from TÜV SÜD Certification and Testing (China) Co., Ltd. – Shanghai Branch issued reports.

This report is the confidential property of the client. As a mutual protection to our clients, the public and ourselves, extracts from the test report shall not be reproduced except in full without our written approval

Table of Content

1	Report Version	4
2	General Information	5
2.1	Notes	5
2.2	Testing Laboratory	6
2.3	Details of Applicant	6
2.4	Application Details	6
2.5	Applied Standard	7
2.6	Test Summary	7
3	Equipment Specification.....	8
3.1	General Description	8
3.2	EUT Identity	8
3.3	Product Description –manufacturer description	9
3.4	Operating Frequency Range, Modulation and Throughput	10
3.5	Additional information	11
4	General Test Conditions / Configurations	12
4.1	Test Sample.....	12
4.2	Test Modes	12
4.3	Frequencies under Test	12
4.4	Test Setups	12
4.5	Test Conditions.....	15
5	Test Results	17
6	Test Requirements	18
6.1	RF output power	18
6.2	Maximum EIRP Spectral Density	18
6.3	Adaptivity	18
6.4	Occupied Channel Bandwidth	18
6.5	Transmitter unwanted emissions in the out-of-band domain	19
6.6	Transmitter Spurious Emissions	19
6.7	Receiver Spurious Emissions.....	20
6.8	Receiver Blocking	20
6.9	Estimation of Exposure of Human to Electromagnetic Fields	22
7	Main Test Instruments	23
8	System Measurement Uncertainty.....	24



China

9	Appendix A: RF output power.....	25
10	Appendix B: Maximum EIRP Spectral Density.....	26
11	Appendix C: Occupied Channel Bandwidth.....	26
12	Appendix D: Transmitter unwanted emissions in the out-of-band domain.....	26
13	Appendix E: Transmitter Spurious Emissions – Radiated Mode.....	27
14	Appendix F: Receiver Spurious Emissions-Radiated Mode.....	30
15	Appendix G: Receiver Blocking.....	31
16	Appendix H: Test Setup Photos.....	32
17	Appendix I: Photographs of EUT.....	33



1 Report Version

Revision	Release Date	History/Memo.
1.0	May 10, 2022	Initial Release
2.0	July 20,2022	Only changed the product name from "LED device" to "Rope light". This revised report replaced all the version issued before.

2 General Information

2.1 Notes

TÜV SÜD Certification and Testing (China) Co., Ltd. – Shanghai Branch is a subcontractor to TÜV SÜD Product Service GmbH according to the principles outlined in ISO 17025.

TÜV SÜD Certification and Testing (China) Co., Ltd. – Shanghai Branch reports apply only to the specific samples tested under stated test conditions. Construction of the actual test samples has been documented. It is the manufacturer's responsibility to assure that additional production units of this model are manufactured with identical electrical and mechanical components. The manufacturer/importer is responsible to the Competent Authorities in Europe for any modifications made to the production units which result in non-compliance to the relevant regulations. TÜV SÜD Certification and Testing (China) Co., Ltd. – Shanghai Branch shall have no liability for any deductions, inferences or generalizations drawn by the client or others from TÜV SÜD Certification and Testing (China) Co., Ltd. – Shanghai Branch issued reports.

This report is the confidential property of the client. As a mutual protection to our clients, the public and ourselves, extracts from the test report shall not be reproduced except in full without our written approval.

The sample's mentioned in this report is/are submitted/ supplied/ manufactured by client. The laboratory therefore assumes no responsibility for accuracy of information on the brand name, model number, origin of manufacture, consignment, antenna gain or any information supplied.

Prepared by
Project Engineer

2022-07-20
Date

Jiaxi XU
Name

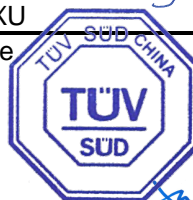

Jiaxi Xu

Signature

Approved by
Review Engineer

2022-07-20
Date

Zhining ZHANG
Name

Zhining Zhang

Signature



2.2 Testing Laboratory

Site 1

Company name: TÜV SÜD Certification and Testing (China) Co., Ltd. Shanghai Branch

Company Address: No.16 Lane, 1951 Du Hui Road,
Shanghai 201108,
P.R. China

Telephone: +86 21 6141 0123

Fax: +86 21 6140 8600

2.3 Details of Applicant

Client: Signify (China) Investment Co., Ltd.
Address: Building No. 9, Lane 888, Tianlin Road
Minhang 200233 Shanghai PEOPLE'S REPUBLIC OF CHINA
Product Description: Rope light
Submitted Model No.: 9290034985,9290034986,9290034987

2.4 Application Details

Date of receipt of test item: January 21, 2022
Date of test: January 23, 2022 ~ March 10, 2022

2.5 Applied Standard

APPLIED PRODUCT STANDARD **ETSI EN 300 328 V2.2.2 (2019-07)**
EN 62479:2010
EN 50663:2017

2.6 Test Summary

Table1. Summary of results

Conformance requirement according to ETSI EN 300 328 V2.2.2 (2019-07)		Result	Test Site
Essential parameter	Corresponding technical requirements		
Transmitter requirements	4.3.1.2/4.3.2.2 RF output power	PASS	Site 1
	4.3.2.3 Power Spectral Density	PASS	Site 1
	4.3.1.3/4.3.2.4 Duty Cycle, Tx-sequence, Tx-gap**	N/A	N/A
	4.3.1.4 Dwell time, Minimum Frequency Occupation and Hopping Sequence*	N/A	N/A
	4.3.1.5 Hopping Frequency Separation*	N/A	N/A
	4.3.1.6/4.3.2.5 Medium Utilisation (MU) factor**	N/A	N/A
	4.3.1.7/4.3.2.6 Adaptivity****	N/A	N/A
	4.3.1.8/4.3.2.7 Occupied Channel Bandwidth	PASS	Site 1
	4.3.1.9/4.3.2.8 Transmitter unwanted emissions in the out-of-band domain	PASS	Site 1
	4.3.1.10/4.3.2.9 Transmitter unwanted emissions in the spurious domain	PASS	Site 1
Receiver requirements	4.3.1.11/4.3.2.10 Receiver spurious emissions	PASS	Site 1
	4.3.1.12/4.3.2.11 Receiver Blocking	PASS	Site 1
	4.3.1.13/4.3.2.12 Geo-location capability***	N/A	N/A

NOTE1: Measurement taken is within the measurement uncertainty of measurement system.

NOTE2: "*" This requirement applies to all types of equipment using FHSS other than wide band modulations.

NOTE3: "***" This requirement does not apply to adaptive equipment unless operating in a non-adaptive mode.

NOTE4: "****" This requirement only applies to equipment with geo-location capability.

NOTE5: "*****" These requirements do not apply for equipment with a maximum declared RF Output power of less than 10 dBm e.i.r.p.

3 Equipment Specification

3.1 General Description

The EUT is a Rope light with Zigbee and BLE function. This report is only for 2.4G Zigbee, for the 2.4GHz BLE test report please refer to 709502203711-00B.

There are 3 models in all, only different is the size of the Rope light. We chose model 9290034987 to perform all tests and listed the worst data in this report.

3.2 EUT Identity

NOTE: Unless otherwise noted in the report, the functional boards installed in the units shall be selected from the below list, but not means all the functional boards listed below shall be installed in one unit.

3.2.1 Technical data

Description:	Rope light
Models:	9290034985,9290034986,9290034987
Hardware version	V1.X
Software version	V1.X
Input Rated Voltage	220-240V~, 50/60Hz

Operation Frequency each of channel: Zigbee			
Channel	Frequency	Channel	Frequency
11	2405 MHz	19	2445 MHz
12	2410 MHz	20	2450 MHz
13	2415 MHz	21	2455 MHz
14	2420 MHz	22	2460 MHz
15	2425 MHz	23	2465 MHz
16	2430 MHz	24	2470 MHz
17	2435 MHz	25	2475 MHz
18	2440 MHz	26	2480 MHz

Operation Frequency each of channel: Bluetooth Low Energy							
Ch	Fre(MH	Ch	Fre(MH	Ch	Fre(MH	Ch	Fre(MHz)
0	2402	10	2422	20	2442	30	2462
1	2404	11	2424	21	2444	31	2464
2	2406	12	2426	22	2446	32	2466
3	2408	13	2428	23	2448	33	2468
4	2410	14	2430	24	2450	34	2470
5	2412	15	2432	25	2452	35	2472
6	2414	16	2434	26	2454	36	2474
7	2416	17	2436	27	2456	37	2476
8	2418	18	2438	28	2458	38	2478
9	2420	19	2440	29	2460	39	2480

Remark 1: The above EUT's information is declared by manufacturer. Please refer to the specifications or user's manual for more detailed description.

3.3 Product Description –manufacturer description

3.3.1 Type of Tested Equipment

<input checked="" type="checkbox"/> Zigbee	<input type="checkbox"/> IEEE 802.11	Other supply full details: _____	
<input checked="" type="checkbox"/> Stand-alone	<input type="checkbox"/> Plug-in radio	<input type="checkbox"/> Combined equipment	<input type="checkbox"/> Other

3.3.2 Extreme operating condition as declared by manufacturer

Power source description			
<input checked="" type="checkbox"/> AC mains voltage		<input type="checkbox"/> DC voltage Nominal	
Type of DC			
<input type="checkbox"/> Internal Power Supply	<input type="checkbox"/> External AC/DC Adapter	<input type="checkbox"/> Battery	<input type="checkbox"/> Other
Extreme Test Voltage [manufacturer declared]			
VN = Nominal voltage [V]	VH = Max Voltage [V]	VL = Min Voltage [V]	
230V~	240V~	220V~	

EXTREME TEMPERATURE RANGE [manufacturer declared]			
Environment class /Operating Temperature	TL = Minimum Temperature [°C]	TN = Normal Temperature [°C]	TH = Maximum Temperature [°C]
<input checked="" type="checkbox"/> Other [declared by manufacturer in UM]	-20	25	75

3.3.3 Type of adaptivity used

<input type="checkbox"/> Non-adaptive	<input checked="" type="checkbox"/> Adaptive	<input checked="" type="checkbox"/> LBT	<input type="checkbox"/> Non LBT
	<input type="checkbox"/> The system can operate in more than one adaptive mode	<input checked="" type="checkbox"/> System can operate both adaptive & non adaptive mode	
	<input type="checkbox"/> Frame Based Equipment	<input checked="" type="checkbox"/> Load Based Equipment	
		CCA time implemented [uS]	>20
		q as referred by 4.3.2.5.2.2.2	4-32

3.3.4 Antenna Assemblies Profiles

Antenna Type	<input checked="" type="checkbox"/> Integrated	<input type="checkbox"/> External	
Temporary RF connector	<input checked="" type="checkbox"/> Provided	<input type="checkbox"/> Not- provided	
<input checked="" type="checkbox"/> SISO - Single antenna equipment	Antenna [dBi] =		2.08dBi
<input type="checkbox"/> MIMO - Multiple antenna without beam forming	Number of transmit antennas=		1
<input type="checkbox"/> MIMO/B - Multiple antenna with beam forming	Beam forming gain [dB] Y =	
Number of receive chains	1	<input type="checkbox"/> Symmetrical power distribution	
Number of transceive chains	1	<input type="checkbox"/> Asymmetrical power distribution	
<input type="checkbox"/> Tx power control (TPC) (antenna connector with multiple power setting)	Nr. of different power level	

3.4 Operating Frequency Range, Modulation and Throughput

Transmitter / Receiver Frequency Range			
<input checked="" type="checkbox"/>	Range 1 : from :	2400 MHz	To 2483.5 MHz
<input type="checkbox"/>	Range 2 : from :		
<input type="checkbox"/>	Other - (include frequency ranges supported):		

Modulation type	
<input type="checkbox"/>	GFSK
<input type="checkbox"/>	$\pi/4$ -DQPSK
<input type="checkbox"/>	8-DPSK
<input checked="" type="checkbox"/>	16-ary orthogonal modulation, O-QPSK PHY
<input type="checkbox"/>	BLE(GFSK)
<input type="checkbox"/>	IEEE 802.11™ [i.3] modulations using a single or multiple transmitters with or without transmit CSD.
<input type="checkbox"/>	HT20: 20 MHz channels with one to four spatial streams (MCS 0 to MCS 76).
<input type="checkbox"/>	HT40: 40 MHz channels with one to four spatial streams (MCS 0 to MCS 76).

3.5 Additional information

The transmitter can operate only:

- Modulated**
- Un-modulated**

ITU Class of emissions 1. 22

Duty Cycle: The transmitter is intended for

- Continuous duty**
- Intermittent duty**
- Continuous operation possible for testing purposes**

About the EUT:

- The equipment submitted are representative production models.**
- If not, the equipment submitted are pre-production models.**
- If preproduction equipment are submitted, the final production equipment will be identical in all respects with the equipment tested.**
- If not, supply full details: _____**

4 General Test Conditions / Configurations

4.1 Test Sample

- The report applies to single model number.
- The report applies to several models. The practical measurements are performed using the model number of 929034987.

4.2 Test Modes

Test Mode	Test Modes Description
Zigbee	TX and RX

4.3 Frequencies under Test

Test Mode	RF Channel		
	Lowest/Bottom (B)	Middle (M)	Highest/Top (T)
Zigbee	Ch No. 11 / 2405 MHz	Ch No. 18 / 2440 MHz	Ch No. 26 / 2480 MHz

4.4 Test Setups

NOTE: See Appendix H for practical Test Setup Photos.

4.4.1 General Test Setup Configurations

Configuration	Description
Test Antenna Ports	Until declared, all Transmitter tests are performed at all antenna ports of the EUT; all Receiver tests are performed at all antenna ports.
Multiple RF Sources	Other non-BLE RF source(s) (if applicable) of the EUT are disabled or shutdown during measurements for Zigbee RF source, which is considered in the present report.

4.4.2 Test Setup for Conducted Measurements

The EUT (Zigbee unit) is placed in a Temperature Chamber (if applicable), and is powered by a Power Supplier. An external Control PC associated with special software(s) is used to configure the EUT (Zigbee unit) with the purpose of fulfilling the test requirements by EN standard.

The antenna port(s) of the EUT (Zigbee unit) are connected to the Measurement Instrument(s) through an appropriate Attenuator. For the antenna port(s) which are not tested, appropriate 50 Ohm terminations are used.

In addition, different setting options (e.g. Option 1) for Measurement Instrument(s) for conducted measurement methods can be used for some test items according to the EN standard. The selected option is specified in test conditions for each test case.

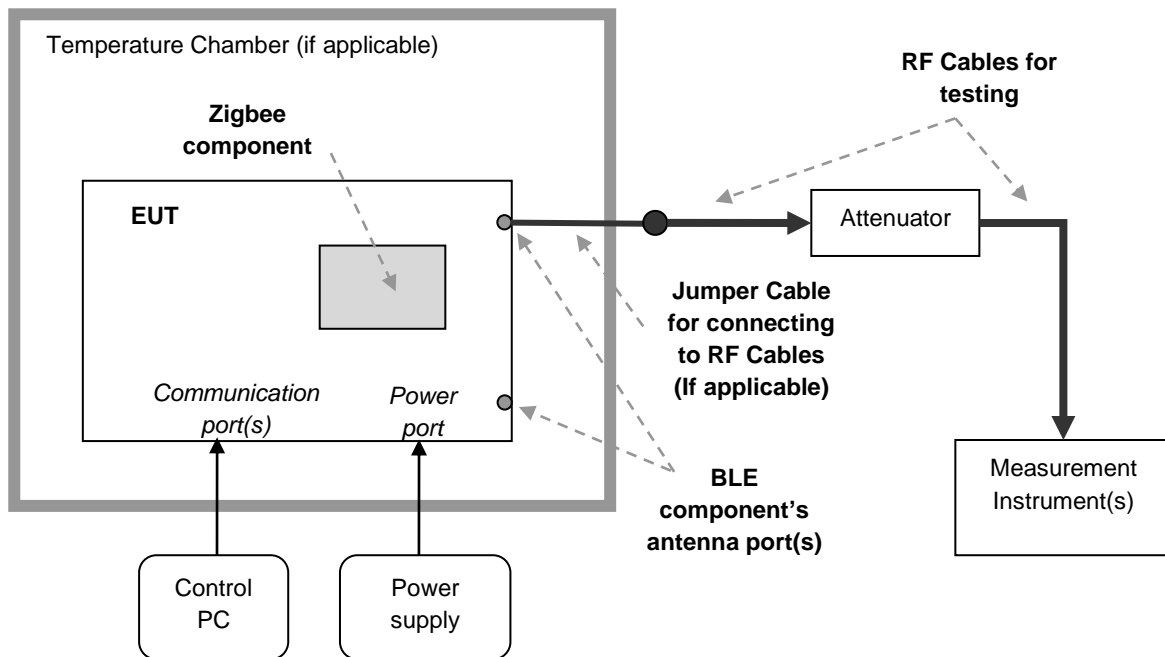

4.4.3 Test Setup for Radiated Measurements

The EUT (Zigbee unit) is placed in a Fully Anechoic Chamber simulating the free-space conditions. The whole device is positioned on a non-conducting support and is powered by a Power Supplier. An external Control PC associated with special software(s) is used to configure the EUT (Zigbee unit) with the purpose of fulfilling the test requirements by EN standards.

An appropriate Measurement Antenna (according to different test frequency ranges) with the distance of 3 m to the whole device is used to obtain maximum response from the whole device, which is rotated when measurement running. The measurement is performed with the Measurement Antenna in both horizontal and vertical polarization planes.

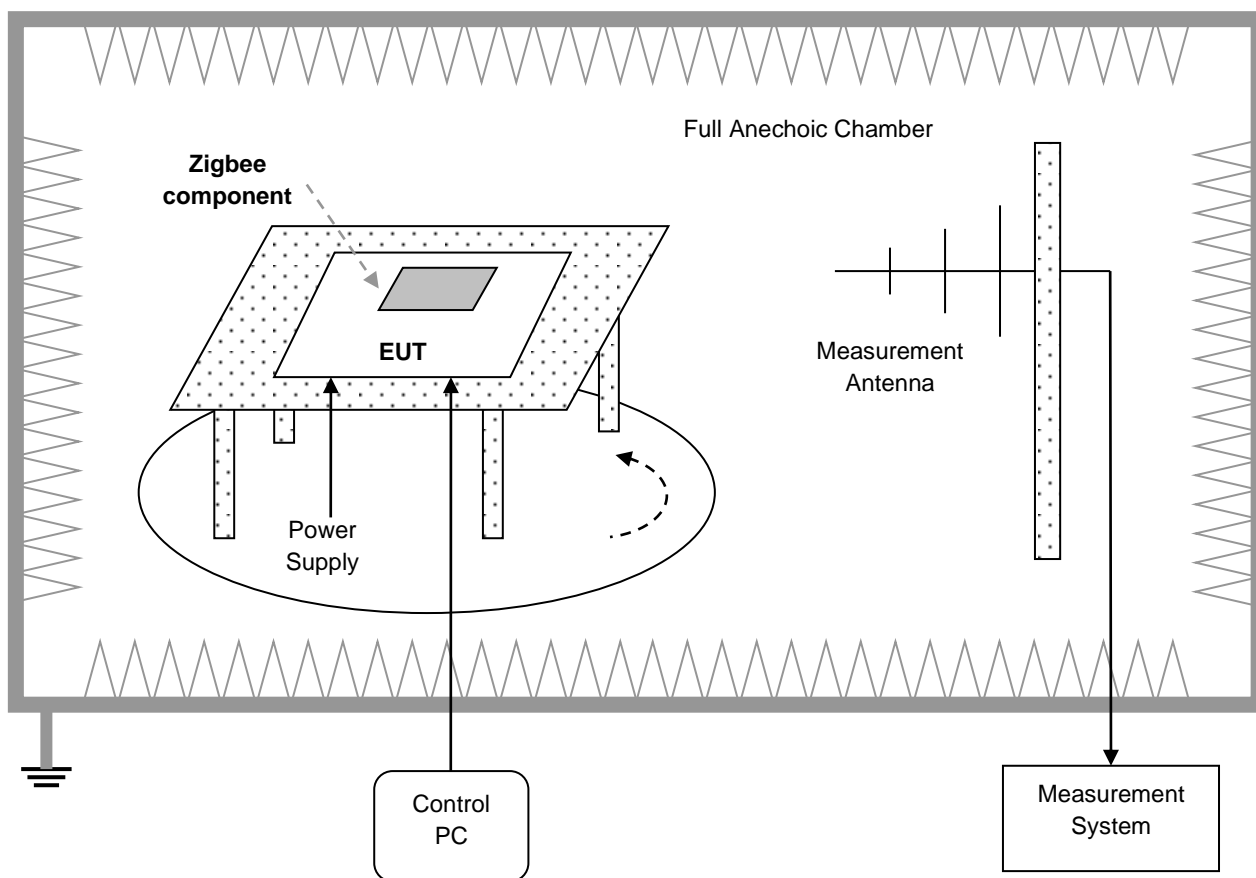

4.5 Test Conditions

Test Case	Test Conditions	
	Configuration	Description
Equivalent Isotropic Radiated Power (EIRP)	Measurement Method	Conducted
	Power Level	Highest
	Test Conditions	NTNV, LTNV, HTNV
	Smart Antenna Systems	Ant 1
	Test Modes	Zigbee
	Test Frequency	L, M, H
Maximum EIRP Spectral Density	Measurement Method	Conducted, Option 1
	Power Level	Highest
	Test Conditions	NTNV
	Smart Antenna Systems	Ant 1
	Test Modes	Zigbee
	TX ON time (>10µs)	Fulfilled
	Test Frequency	L, M, H
Occupied Channel Bandwidth	Measurement Method	Conducted, Option 1
	Test Conditions	NTNV
	Smart Antenna Systems	Ant 1
	Test Modes	Zigbee
	Transmitter Mode	Operating
	Test Frequency	L, H
Transmitter unwanted emissions in the out-of-band domain	Measurement Method	Conducted, Option 1
	Test Conditions	NTNV
	Smart Antenna Systems	Ant 1
	Test Modes	Zigbee

Test Case	Test Conditions	
	Configuration	Description
	Test Frequency	L, H
Transmitter unwanted emissions in the spurious domain	Measurement Method	Radiated
	Test Conditions	NTNV
	Smart Antenna Systems	Ant 1
	Test Modes	Zigbee
	Transmitter Mode	Operating
	Test Frequency	L, H
Receiver Spurious Emissions	Measurement Method	Radiated
	Test Conditions	NTNV
	Smart Antenna Systems	Ant 1
	Test Modes	Zigbee
	Receiver Mode	Continues Receiving
	Test Frequency	L, H
Receiver Blocking	Measurement Method	Conducted, Option 1
	Power Level	Highest
	Test Conditions	NTNV
	Smart Antenna Systems	Ant 1
	Test Modes	Zigbee
	Transmitter Mode	Operating
	Test Frequency	L, H

5 Test Results

No.	Test Item	Test Result
1	4.3.2.2 RF output power	Appendix A
2	4.3.2.3 Power Spectral Density	Appendix B
3	4.3.2.4 Duty Cycle, Tx-sequence, Tx-gap	N/A
4	4.3.2.5 Medium Utilisation (MU) factor	N/A
5	4.3.2.6 Adaptivity	N/A
6	4.3.2.7 Occupied Channel Bandwidth	Appendix C
7	4.3.2.8 Transmitter unwanted emissions in the out-of-band domain	Appendix D
8	4.3.2.9 Transmitter unwanted emissions in the spurious domain_Radiated	Appendix E
9	4.3.2.9 Transmitter unwanted emissions in the spurious domain_Conducted	N/A
10	4.3.2.10 Receiver spurious emissions_Radiated	Appendix F
11	4.3.2.10 Receiver spurious emissions_Conducted	N/A
12	4.3.2.11 Receiver Blocking	Appendix G

6 Test Requirements

6.1 RF output power

The equivalent isotropic radiated power (as EIRP) shall be equal to or less than -10 dBW (= 20 dBm). This limit shall apply for any combination of power level and intended antenna assembly.

6.2 Maximum EIRP Spectral Density

For wide band modulations other than FHSS (e.g. DSSS, OFDM, etc.), the maximum e.i.r.p. spectral density (as PD) is limited to 10 mW per MHz (= 10 dBm/MHz).

6.3 Adaptivity

The equipment used Non-LBT based Detect and Avoid mechanism shall comply with the requirements defined in clause 4.3.2.6.2.2

LBT based Detect and Avoid mechanism: This mechanism defines 2 types of adaptive equipment using wide band modulations and that uses an LBT based Detect and Avoid mechanism: Frame Based Equipment and Load Based Equipment. The kind of the equipment shall comply with the requirements defined in clause 4.3.2.6.3.2

Short Control Signalling Transmissions: The transmissions used by adaptive equipment to send control signals (e.g. ACK/NACK signals, etc.) without sensing the operating channel for the presence of other signals. Adaptive equipment may or may not have Short Control Signalling Transmissions. If implemented, the limit of Short Control Signalling Transmissions of adaptive equipment using wide band modulations shall have a maximum duty cycle of 10 % within an observation period of 50 ms.

6.4 Occupied Channel Bandwidth

The Occupied Channel Bandwidth shall fall completely within the band given in table 1.

In addition, for non-adaptive equipment using wide band modulations other than FHSS and with e.i.r.p. greater than 10 dBm, the occupied channel bandwidth shall be less than 20 MHz.

Table 1: Service frequency bands

	Service frequency bands
Transmit	2 400 MHz to 2 483,5 MHz
Receive	2 400 MHz to 2 483,5 MHz

6.5 Transmitter unwanted emissions in the out-of-band domain

The transmitter unwanted emissions in the out-of-band domain but outside the allocated band, shall not exceed the values provided by the mask in below figure.

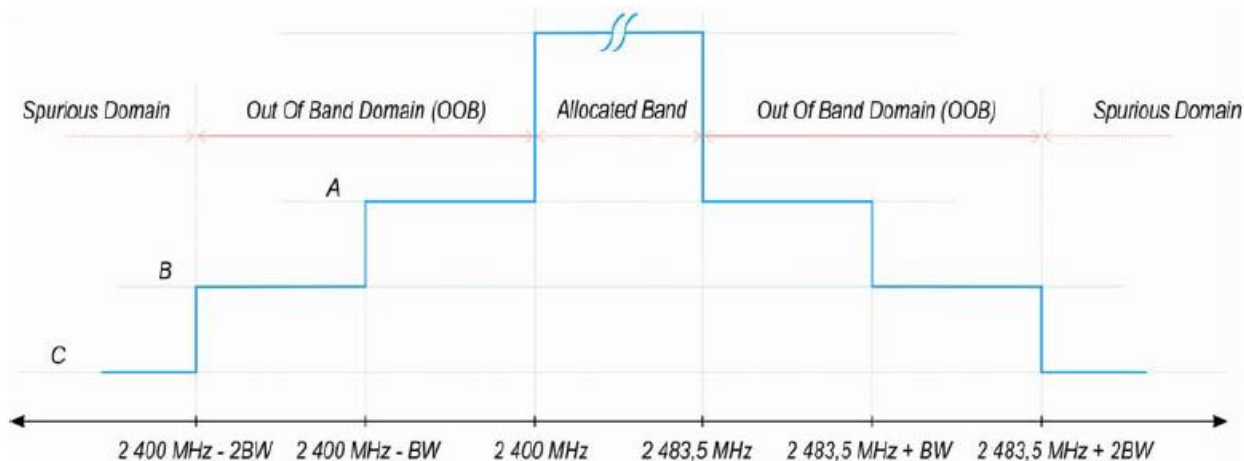

A: -10 dBm/MHz e.i.r.p.
 B: -20 dBm/MHz e.i.r.p.
 C: Spurious Domain limits

BW = Occupied Channel Bandwidth in MHz or 1 MHz whichever is greater

NOTE: Within the 2 400 MHz to 2 483.5 MHz band, the Out-of-band emissions are fulfilled by compliance with the Occupied Channel Bandwidth requirement in clause 4.3.2.7.

6.6 Transmitter Spurious Emissions

The spurious emissions of the transmitter shall not exceed the values in following tables in the indicated bands.

Frequency Range	Limit When Operating	Limit When in Standby
30MHz to 47MHz	-36dBm	-57 dBm
47MHz-74MHz	-54dBm	-57 dBm
74MHz-87.5MHz	-36dBm	-57 dBm
87.5MHz-118MHz	-54dBm	-57 dBm
118MHz-174MHz	-36dBm	-57 dBm
174MHz-230MHz	-54dBm	-57 dBm
230MHz-470MHz	-36dBm	-57 dBm
470MHz-694MHz	-54dBm	-57 dBm
694MHz-1GHz	-36dBm	-57 dBm
Above 1GHz to 12.75GHz	-30dBm	-47 dBm

NOTE: The above limit values apply to narrowband emissions, e.g. as caused by local oscillator leakage. The measurement bandwidth for such emissions may be as small as necessary to achieve a reliable measurement result.

6.7 Receiver Spurious Emissions

The spurious emissions of the receiver shall not exceed the values in following tables in the indicated bands.

Frequency Range	Limit
30 MHz to 1 GHz	-57 dBm
1 GHz to 12.75 GHz	-47 dBm

Note: The above limit values apply to narrowband emissions, e.g. as caused by local oscillator leakage. The measurement bandwidth for such emissions may be as small as necessary to achieve a reliable measurement result.

6.8 Receiver Blocking

While maintaining the minimum performance criteria as defined in clause 4.3.2.11.3, the blocking levels at specified frequency offsets shall be equal to or greater than the limits defined for the applicable receiver category provided in table 14, table 15 or table 16.

Table 14 contains the Receiver Blocking parameters for Receiver Category 1 equipment.

Table 14: Receiver Blocking parameters for Receiver Category 1 equipment

Wanted signal mean power from companion device (dBm) (see notes 1 and 4)	Blocking signal frequency (MHz)	Blocking signal power (dBm) (see note 4)	Type of blocking signal
$(-133 \text{ dBm} + 10 \times \log_{10}(\text{OCBW}))$ or -68 dBm whichever is less (see note 2)	2 380 2 504	-34	CW
$(-139 \text{ dBm} + 10 \times \log_{10}(\text{OCBW}))$ or -74 dBm whichever is less (see note 3)	2 300 2 330 2 360 2 524 2 584 2 674		
NOTE 1: OCBW is in Hz.			
NOTE 2: In case of radiated measurements using a companion device and the level of the wanted signal from the companion device cannot be determined, a relative test may be performed using a wanted signal up to $P_{\min} + 26 \text{ dB}$ where P_{\min} is the minimum level of wanted signal required to meet the minimum performance criteria as defined in clause 4.3.1.12.3 in the absence of any blocking signal.			
NOTE 3: In case of radiated measurements using a companion device and the level of the wanted signal from the companion device cannot be determined, a relative test may be performed using a wanted signal up to $P_{\min} + 20 \text{ dB}$ where P_{\min} is the minimum level of wanted signal required to meet the minimum performance criteria as defined in clause 4.3.1.12.3 in the absence of any blocking signal.			
NOTE 4: The level specified is the level at the UUT receiver input assuming a 0 dBi antenna assembly gain. In case of conducted measurements, this level has to be corrected for the (in-band) antenna assembly gain (G). In case of radiated measurements, this level is equivalent to a power flux density (PFD) in front of the UUT antenna with the UUT being configured/positioned as recorded in clause 5.4.3.2.2.			

Table 15 contains the Receiver Blocking parameters for Receiver Category 2 equipment.

Table 15: Receiver Blocking parameters receiver Category 2 equipment

Wanted signal mean power from companion device (dBm) (see notes 1 and 3)	Blocking signal frequency (MHz)	Blocking signal power (dBm) (see note 3)	Type of blocking signal
$(-139 \text{ dBm} + 10 \times \log_{10}(\text{OCBW}) + 10 \text{ dB})$ or $(-74 \text{ dBm} + 10 \text{ dB})$ whichever is less (see note 2)	2 380 2 504 2 300 2 584	-34	CW
NOTE 1: OCBW is in Hz. NOTE 2: In case of radiated measurements using a companion device and the level of the wanted signal from the companion device cannot be determined, a relative test may be performed using a wanted signal up to $P_{\min} + 26 \text{ dB}$ where P_{\min} is the minimum level of wanted signal required to meet the minimum performance criteria as defined in clause 4.3.1.12.3 in the absence of any blocking signal. NOTE 3: The level specified is the level at the UUT receiver input assuming a 0 dBi antenna assembly gain. In case of conducted measurements, this level has to be corrected for the (in-band) antenna assembly gain (G). In case of radiated measurements, this level is equivalent to a power flux density (PFD) in front of the UUT antenna with the UUT being configured/positioned as recorded in clause 5.4.3.2.2.			

Table 16 contains the Receiver Blocking parameters for Receiver Category 3 equipment.

Table 16: Receiver Blocking parameters receiver Category 3 equipment

Wanted signal mean power from companion device (dBm) (see notes 1 and 3)	Blocking signal frequency (MHz)	Blocking signal power (dBm) (see note 3)	Type of blocking signal
$(-139 \text{ dBm} + 10 \times \log_{10}(\text{OCBW}) + 20 \text{ dB})$ or $(-74 \text{ dBm} + 20 \text{ dB})$ whichever is less (see note 2)	2 380 2 504 2 300 2 584	-34	CW
NOTE 1: OCBW is in Hz. NOTE 2: In case of radiated measurements using a companion device and the level of the wanted signal from the companion device cannot be determined, a relative test may be performed using a wanted signal up to $P_{\min} + 30 \text{ dB}$ where P_{\min} is the minimum level of wanted signal required to meet the minimum performance criteria as defined in clause 4.3.1.12.3 in the absence of any blocking signal. NOTE 3: The level specified is the level at the UUT receiver input assuming a 0 dBi antenna assembly gain. In case of conducted measurements, this level has to be corrected for the (in-band) antenna assembly gain (G). In case of radiated measurements, this level is equivalent to a power flux density (PFD) in front of the UUT antenna with the UUT being configured/positioned as recorded in clause 5.4.3.2.2.			

6.9 Estimation of Exposure of Human to Electromagnetic Fields

The product has an operation frequency of [2405-2480MHz], and the maximum transmitted power is 8.70dBm (7.41mW).

According with EN 50663:2017 clause 6, EN 62479:2010,4.1 and clause 6, Equipment complying with the requirements for the general public is deemed to comply with the requirements for workers without further testing if it can be demonstrated using routes B, C or D that the available antenna power and/or the average total radiated power is less than or equal to the values of Pmax. The peak output power of the product is 4.37mW; it is less than the limit 20mW which list in the table 1, so the equipment complies with EMF basic restrictions in EN 50663:2017 and EN 62479:2010.

7 Main Test Instruments

List of Test Instruments

Test Site1

	DESCRIPTION	MANUFACTURER	MODEL NO.	SERIAL NO.	CAL. DATE	CAL. DUE DATE
C	Wideband Radio Communication Tester	R&S	CMW500	S2110416b-YQ-EMC	2021-11-26	2022-11-25
	Vector signal generator	Agilent	N5182A	S2110417b-YQ-EMC	2021-11-28	2022-11-27
	RF automatic control unit	MWRfTest	MW100-RFCB	S2110418b-YQ-EMC	2021-11-28	2022-11-27
	Temperature Chamber	Kushan Bositong	BST-TC-415T	S1908307-YQ-EMC	2021-12-1	2022-11-30
	Signal Analyzer	R & S	FSV40	S1503003-YQ-EMC	2021-8-2	2022-8-1
RE	EMI test receiver	R & S	ESR3	S1503109-YQ-EMC	2021-8-2	2022-8-1
	Signal Analyzer	R & S	FSV40	S1503003-YQ-EMC	2021-8-2	2022-8-1
	Trilog super broadband test antenna	SCHWARZBECK	VULB 9168	S1808296-YQ-EMC	2021-9-23	2024-9-22
	Horn Antenna	R & S	HF907	S1503009-YQ-EMC	2021-4-13	2024-4-12
	Pre-amplifier	R & S	SCU-18D	S1503012-YQ-EMC	2021-8-2	2022-8-1
	3 meter semi-anechoic chamber	TDK	3m	S1503231-YQ-EMC	2021-5-8	2024-5-7
Measurement Software Information						
Test Item	Software	Manufacturer	Version			
C	MTS 8310	MWRfTest	2.0.0.0			
RE	EMC 32	R & S	V10.50.40			

Conducted RF tests –C

- RF output power
- Power Spectral Density
- Adaptivity & Receiver Blocking
- Occupied Channel Bandwidth
- Transmitter unwanted emissions OOB

Radiated RF tests- RE

- Radiated unwanted emissions spurious TX
- Radiated unwanted emissions spurious RX

8 System Measurement Uncertainty

For the test methods, according to the harmonized standard and conformance testing standard, the measurement uncertainty figures shall be calculated in accordance with TR 100 028 and shall correspond to an expansion factor (coverage factor) $k = 1.96$ (which provides a confidence level of 95 % in the case where the distributions characterizing the actual measurement uncertainties are normal (Gaussian)).

System Measurement Uncertainty	
Test Items	Extended Uncertainty
Uncertainty for Radiated Spurious Emission 30MHz-1000MHz	$\pm 3.49\text{dB}$ (Horizontal), $\pm 3.50\text{dB}$ (Vertical)
Uncertainty for Conducted RF test	Power level test involved: 2.04dB Frequency test involved: 1.1×10^{-7}

9 Appendix A: RF output power

NOTE 1: In this Appendix, EIRP [dBm] = A [dBm] + G [dBi]+Y(dBi). Where, A = RMS Power, G = Antenna Gain and Y=beamforming (if any). The Jumper Cable Loss (JCL) (if applicable) and Test Path Loss (TPL) were calculated into A.

NOTE 2: For measurements on smart antenna systems (devices with multiple transmit chains), the test is performed at each chain, and then combined into a final result. The result is the calculated linear sum of each chain (as Ant sum).

(1) Common Parameter

Test Mode	Power Level Setting defined by Manufacturer	X [%]	G [dBi]
Zigbee	8dBm	100	2.08

(2) Test Result

Temperature (°C)	Mode	Channel No.	Frequency (MHz)	E.I.R.P (dBm)	Limit (dBm)
NTNV	Zigbee	11	2405	8.35	20.00
		18	2440	8.70	20.00
		26	2480	7.93	20.00
LTVN	Zigbee	11	2405	8.85	20.00
		18	2440	9.35	20.00
		26	2480	8.56	20.00
HTNV	Zigbee	11	2405	7.84	20.00
		18	2440	8.27	20.00
		26	2480	7.43	20.00

10 Appendix B: Maximum EIRP Spectral Density

NOTE 1: In this Appendix, PD [dBm/MHz] = D [dBm/MHz] + G [dBi]+Y(dBi). Where, D = Spectral Power Density, G = Antenna Gain and Y=Beamforming Gain(if any). The Jumper Cable Loss (JCL) (if applicable) and Test Path Loss (TPL) were calculated into D.

NOTE 2: For measurements on smart antenna systems (devices with multiple transmit chains), the test is performed at each chain, and then combined into a final result. The result is the calculated linear sum of each chain (as Ant sum).

(1) Common Parameter

Test Mode	Power Level Setting defined by Manufacturer	X [%]	G [dBi]
Zigbee	8dBm	100	2.08

(2) Test Result

Test Mode	RF Ch.	Ant.	PD [dBm/MHz]	Limit [dBm/MHz]	Verdict
Zigbee	L	Ant 1	6.03	< 10	PASS
	M	Ant 1	6.44	< 10	PASS
	H	Ant 1	5.74	< 10	PASS

11 Appendix C: Occupied Channel Bandwidth

Channel	Frequency (MHz)	Occupied Channel Bandwidth (MHz)	Frequency (MHz)		Limit
			FL(MHz)	FH(MHz)	
11	2405	1.894	2403.061	--	FL>2400MHz and FH<2483.5MHz
26	2480	1.894	--	2481.009	

12 Appendix D: Transmitter unwanted emissions in the out-of-band domain

Zigbee:

Test condition:	Test frequency (MHz)	Test segment (MHz)	Max. Reading (dBm/MHz)	Limit (dBm/MHz)
NTNV	2405	2400-BW to 2400	-41.62	-10
		2400-2BW to 2400-BW	-44.75	-20
	2480	2483.5 to 2483.5+BW	-39.11	-10
		2483.5+BW to 2483.5+2BW	-42.93	-20

13 Appendix E: Transmitter Spurious Emissions – Radiated Mode

NOTE 1: The whole testing range is from “30 MHz to 12.75 GHz” is divided into 2 parts according to the test site settings, which are:

- Part 1: Test range of “30 MHz to 1GHz”,
- Part 2: Test range of “1 GHz to 12.75 GHz”.

NOTE 2: In this Appendix, X = Duty Cycle and G = Antenna Gain. The test path transducer was directly calculated into results for each test range.

(1) Common Parameter

Test Mode	Power Level Setting defined by Manufacturer	X [%]	G [dBi]
Zigbee	8dBm	100	2.08

(2) Test Result

Note: The test results for testing range of “30 MHz to 12.75 GHz” showed as below is **the WORST case for all Test Modes and Channels**. The detected values which are noise floor or below the limit 20dB will not be recorded.

Transmitting spurious emission test result as below:

Zigbee					
Channel 11 (2405MHz)					
Frequency (MHz)	Maximum Emission Observed(dBm)	Limit (dBm)	Margin (dB)	Detector	Polarization
4810.2	-48.84	-30.0	18.84	Peak	Horizontal
7215.5	-49.60	-30.0	19.60	Peak	Vertical

Zigbee					
Channel 26 (2480MHz)					
Frequency (MHz)	Maximum Emission Observed(dBm)	Limit (dBm)	Margin (dB)	Detector	Polarization
4960.3	-45.02	-30.0	15.02	Peak	Horizontal
7441.1	-48.15	-30.0	18.15	Peak	Vertical

The worst case of Radiated Emission below 1GHz:

Site: 3 meter chamber	Time: 2022/03/09 - 16:23
Limit: EN 300 328_RE (3m)	Engineer: Wang Yiquan
Probe: VULB9168	Polarity: Horizontal
UT: Led Lamp, Model no: 9290034987	Power: AC 230V,50Hz
Note: Transmit by at channel 2480MHz (worst case).	

Limit and Margin

Frequency (MHz)	RMS (dBm)	Meas. Time (ms)	Bandwidth (kHz)	Height (cm)	Pol	Azimuth (deg)	Corr. (dB)	Margin - RMS (dB)	Limit - RMS (dBm)
55.46	-70.6	1000.0	120.000	149.9	H	195.0	-79.2	16.6	-54.0
96.88	-67.8	1000.0	120.000	149.9	H	359.0	-76.8	13.8	-54.0
129.32	-64.5	1000.0	120.000	149.9	H	243.0	-78.9	28.5	-36.0
239.76	-68.9	1000.0	120.000	149.9	H	123.0	-77.8	32.9	-36.0
335.00	-66.0	1000.0	120.000	149.9	H	54.0	-74.7	30.0	-36.0
538.42	-64.2	1000.0	120.000	149.9	H	317.0	-71.2	10.2	-54.0

Site: 3 meter chamber	Time: 2022/03/09 - 17:02
Limit: EN 300 328_RE (3m)	Engineer: Wang Yiquan
Probe: VULB9168	Polarity: Vertical
UT: Led Lamp, Model no: 9290034987	Power: AC 230V,50Hz
Note: Transmit by at channel 2480MHz (worst case).	

Limit and Margin

Frequency (MHz)	RMS (dBm)	Meas. Time (ms)	Bandwidth (kHz)	Height (cm)	Pol	Azimuth (deg)	Corr. (dB)	Margin - RMS (dB)	Limit - RMS (dBm)
47.07	-65.6	1000.0	120.000	149.9	V	195.0	-79.2	11.6	-54.0
55.36	-67.1	1000.0	120.000	149.9	V	359.0	-76.8	13.1	-54.0
174.5	-66.2	1000.0	120.000	149.9	V	243.0	-78.9	12.2	-54.0
312.2	-63.9	1000.0	120.000	149.9	V	123.0	-77.8	27.9	-36.0
569.1	-66.0	1000.0	120.000	149.9	V	54.0	-74.7	12.0	-54.0
871.2	-64.2	1000.0	120.000	149.9	V	317.0	-71.2	28.2	-36.0

14 Appendix F: Receiver Spurious Emissions-Radiated Mode

NOTE 1: The whole testing range is from "30 MHz to 12.75 GHz" is divided into 2 parts according to the test site settings, which are:

- Part 1: Test range of "30 MHz to 1 GHz",
- Part 2: Test range of "1 GHz to 12.75 GHz".

NOTE 2: In this Appendix, X = Duty Cycle and G = Antenna Gain. The test path transducer was directly calculated into results for each test range.

(1) Common Parameter

Test Mode	Power Level Setting defined by Manufacturer	X [%]	G [dBi]
Zigbee	8dBm	100	2.08

(2) Test Result

NOTE: Only test results and plots under the WORST case are reported.

Zigbee

Invested Frequency Range(MHz)	Frequency(MHz)	Maximum Emission	DETECTOR	Limit (dBm)	Margin (dB)	Polarization
		Observed(dBm)				
30-1000	518.31	-64.19	PK	-57.00	7.19	H
1000-12750	--	<-70.0	PK	-47.00	>20	H
30-1000	97.68	-69.23	PK	-57.00	12.23	V
1000-12750	--	<-70.0	PK	-47.00	>20	V

Remark: The detected values which are noise floor or below the limit 20dB will not be recorded.

15 Appendix G: Receiver Blocking

Test result:

Test Condition	Test Mode	Test Channel	Ant	Wanted signal Level[dBm]	Freq [MHz]	CW Level [dBm]	PER [%]	Limit [%]	Verdict
NTNV	Receiving	2405	Ant1	-66.23	2380	-34	0.10	<=10	PASS
NTNV	Receiving	2405	Ant1	-66.23	2300	-34	0.10	<=10	PASS
NTNV	Receiving	2480	Ant1	-66.23	2504	-34	0.00	<=10	PASS
NTNV	Receiving	2480	Ant1	-66.23	2584	-34	0.20	<=10	PASS

16 Appendix H: Test Setup Photos

Radiated Emission (30MHz-1GHz)



Radiated Emission (1GHz-12.75GHz)



17 Appendix I: Photographs of EUT

Model: 9290034987

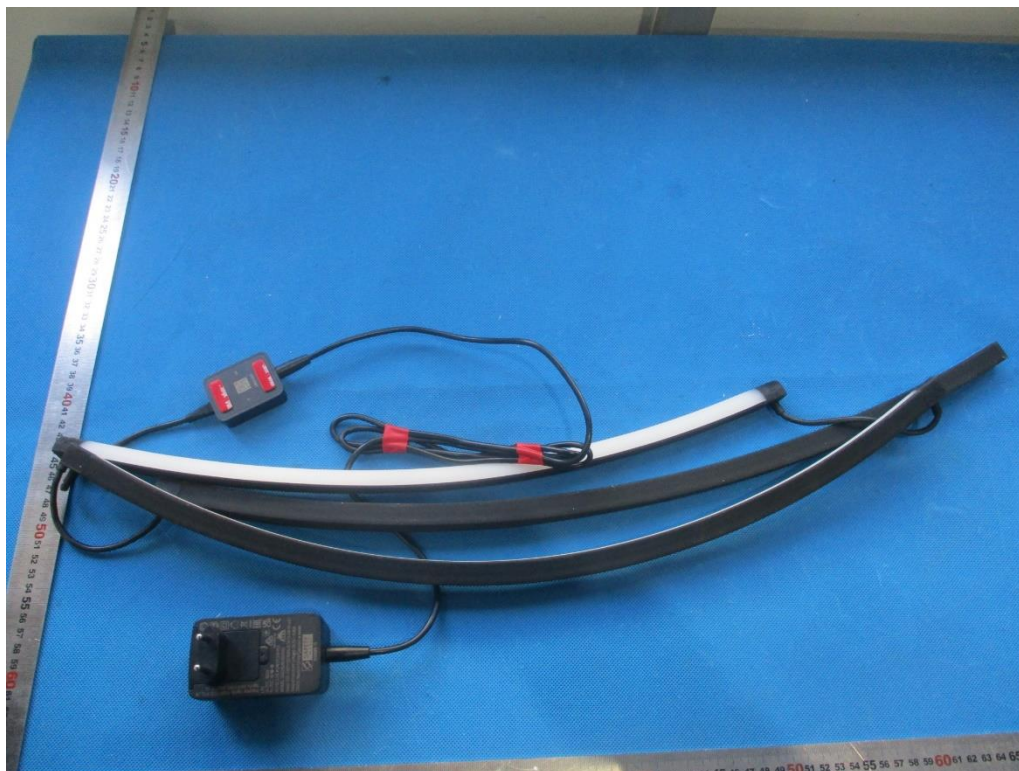

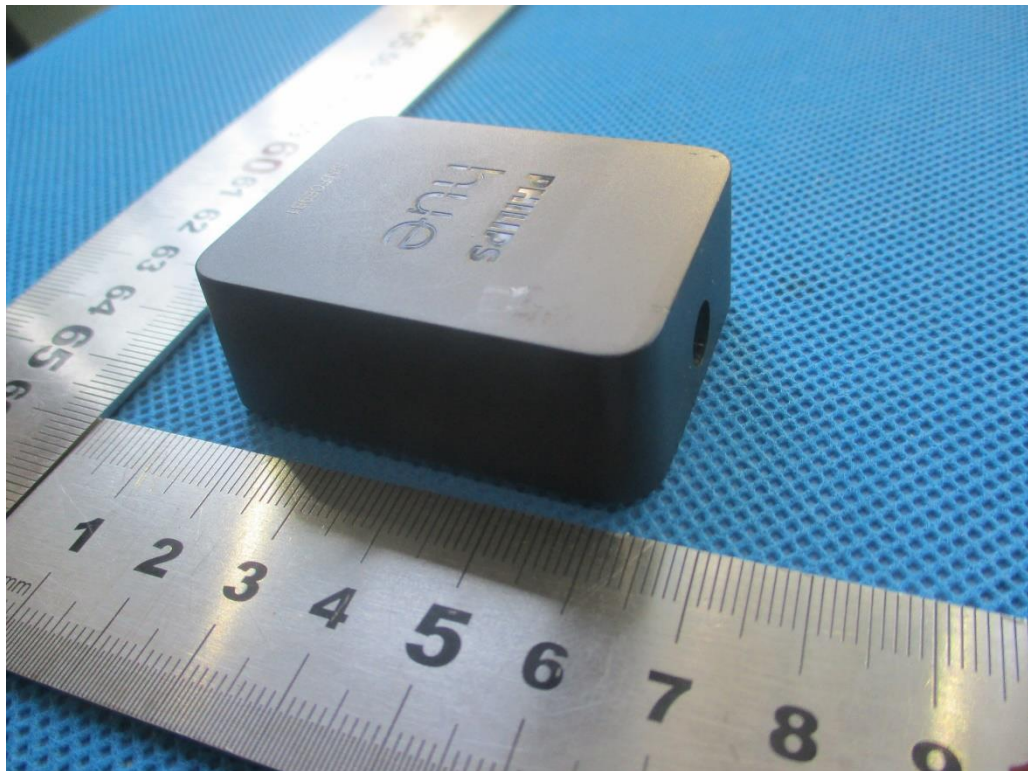

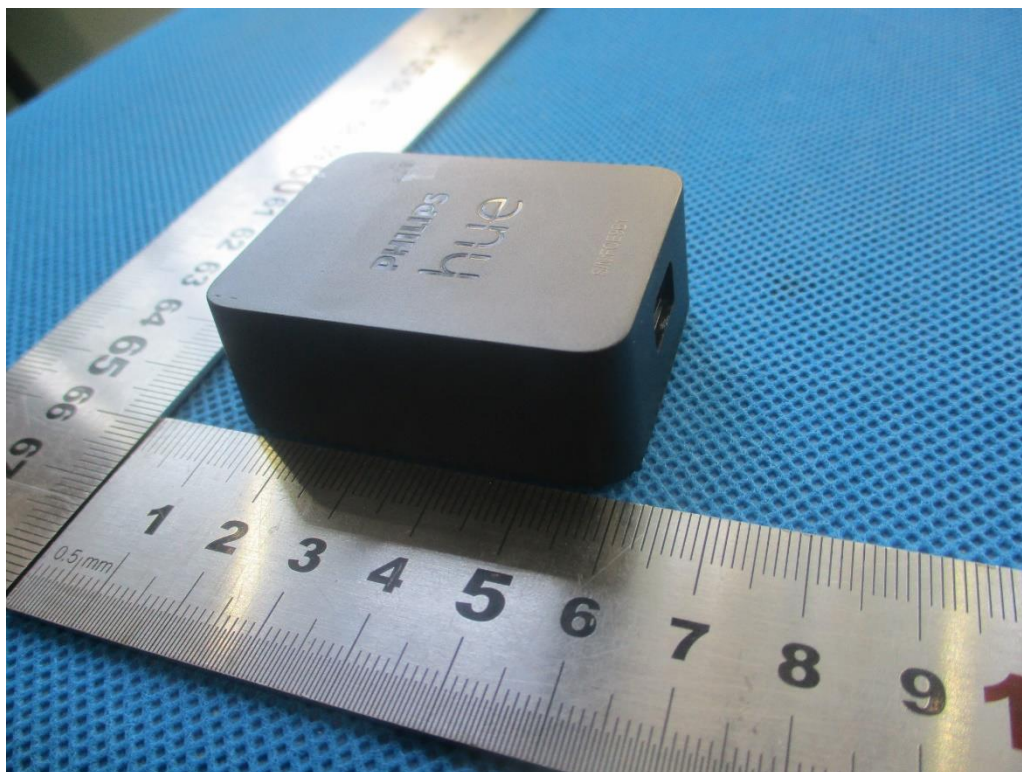

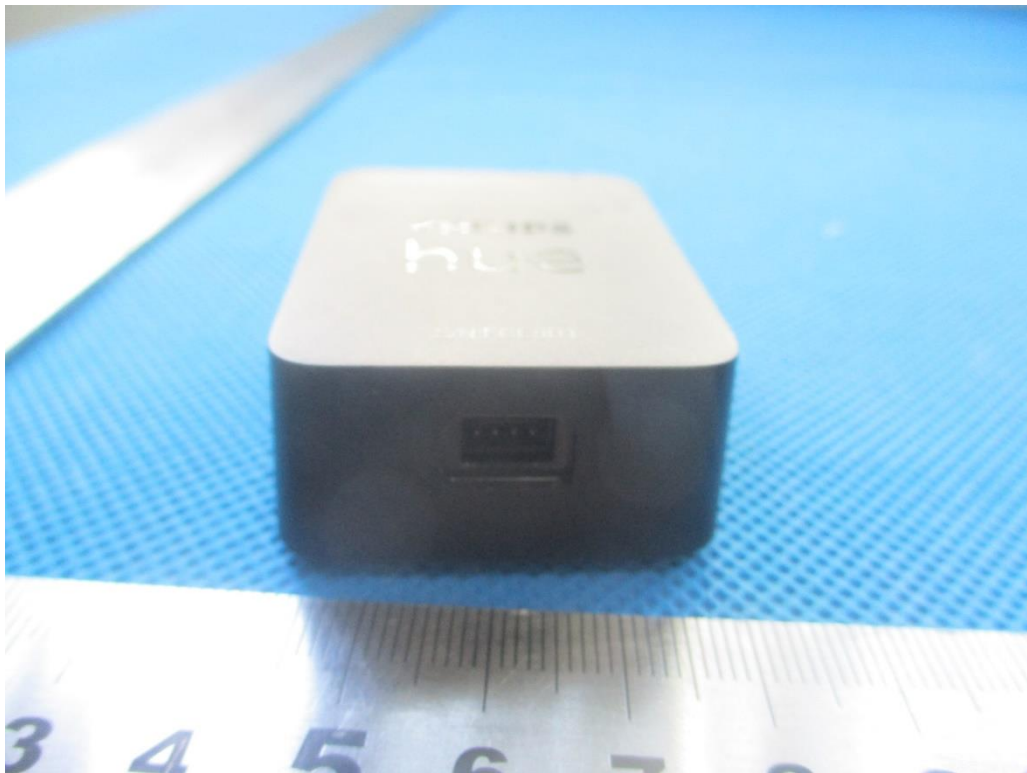

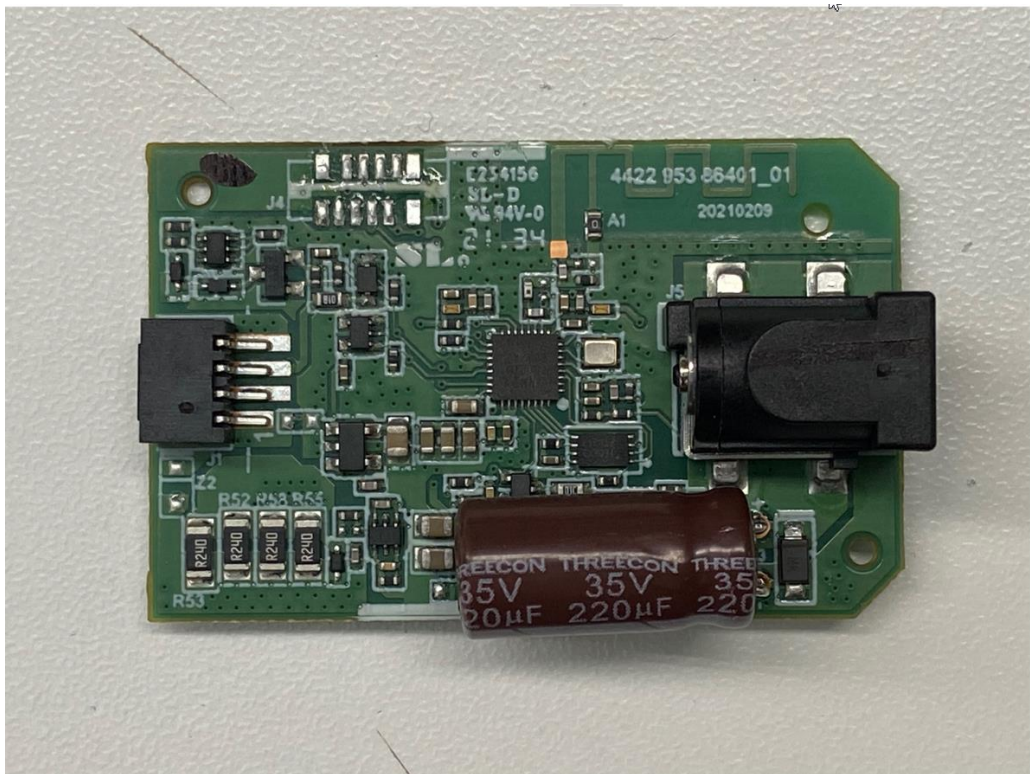

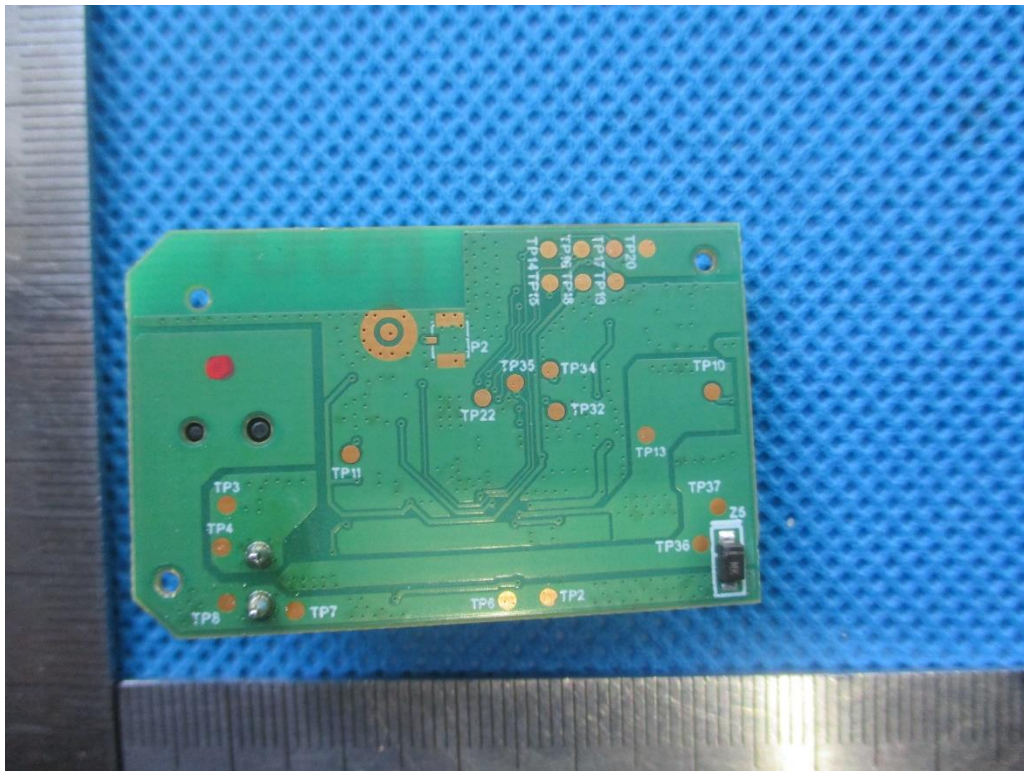

THE END