

## RESOLUCION 737 - SUBTEL

Fecha de publicación: 11/3/2026

---

### Información Comercial

#### Nombre comercial del equipo

Código	Descripción
929002524812	Wi-Fi LEDstrip 2M 1600lm StartKit Type-C

**Fabricante:** Signify (China) Investment Co., Ltd.

**Importador o representante en Chile:** SIGNIFY CHILENA S.A.

**Domicilio:** El Bosque Norte 0211, Las Condes - Santiago

**Correo electrónico de contacto:** tomas.aragona@signify.com

**Sitio Web:** wizconnected.com/es-cl

---

### Características técnicas

Tipo de equipo	Tira LED
Marca	WIZ
Modelo	Wi-Fi LEDstrip 2M 1600lm StartKit Type-C
Módulo	ESP32-SOLO-1
Tecnología o modulación	DSSS, OFDM
Frecuencias	BT: 2402-2480; WiFi: 2412-2472 MHz.
Ganancia de antena (dBi)	2,0 dBi
P.I.R.E. (EIRP)	BT: 43,65 mW (16,4 dBm); WiFi 2,4G: 69,18 mW (18,4 dBm)

---

### Declaración de conformidad

*“El equipo previamente individualizado cumple con las disposiciones establecidas en la Norma Técnica de Equipos de alcance reducido, aprobada por la resolución exenta N° 1.985, de 2017, de la Subsecretaría de Telecomunicaciones.”*

---

Firma del Importador/Responsable:

Nombre de quien firma: Tomás Aragona



Cargo: Representante Legal

- ANT.: 1. Ingreso SUBTEL N° 35607 de 14.03.2024.  
2. Resolución Exenta N° 1985 de 2017, y sus modificaciones, de la Subsecretaría de Telecomunicaciones  
3. Resolución Exenta N° 3.103 de 2012, de la Subsecretaría de Telecomunicaciones.  
4. Resolución Exenta N° 470 de fecha 13.02.2013, que faculta a los jefes de División y de Departamento para firmar "Por Orden del Subsecretario de Telecomunicaciones" y delega las facultades que indica.

MAT.: Certifica equipo de alcance reducido.

DE: SUBSECRETARÍA DE TELECOMUNICACIONES

A: MBSERVICES

1. De acuerdo a la información proporcionada por documento de ANT. 1), esta Subsecretaría de Estado extiende el presente certificado para operar dentro del país, condicionado al estricto cumplimiento de lo señalado en letra(s) j.1) del artículo 1° de la norma señalada en ANT. 2):

- Tipo de Equipo : TIRA LED.
- Marca : WIZ.
- Modelo(s) : 9290025248
- Fabricante : Signify (China) Investment Co., Ltd.
- Frecuencias de operación : BT: 2402-2480; WiFi: 2412-2472 MHz.
- Potencia máxima radiada : BT: 43,65 mW (16,4 dBm); WiFi 2,4G: 69,18 mW (18,4 dBm).
- Restricciones : Estos equipos deben emplear técnicas de compartición de frecuencias.

2. El incumplimiento de lo dispuesto por el presente certificado, será sancionado de acuerdo a las disposiciones legales vigentes. Estos equipos no deberán provocar interferencias a servicios de concesionarias de telecomunicaciones y no estarán protegidos respecto de interferencias que eventualmente puedan recibir.

Saluda atentamente a Ud.,  
Por orden del Subsecretario de Telecomunicaciones

**DISTRIBUCIÓN:**

- MBSERVICES: Laboratorio@mbservices.cl
- Oficina de Partes.

Francisco Javier Pizarro Sepulveda  
Jefe División Fiscalización  
26/03/2024 16:22



Test report No: 4363930.50-RF

## TEST REPORT

### Radio Spectrum Matters (RF)

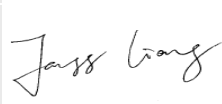
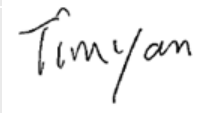
Identification of item tested	LED fixed luminaire
Trademark	<b>PHILIPS</b> or <b>WiZ</b>
Model and /or type reference	Refer table 1
Features	100-240 Vac, 50/60 Hz, 20 W (details refer to table 1)
Derived model(s)	N/A
Applicant's name / address	Signify (China) Investment Co., Ltd. Building No.9, Lane 888, Tianlin Road, Minhang District, Shanghai 200233, China
Test method requested, standard	ETSI EN 300 328 V2.2.2 (2019-07)
Verdict Summary	IN COMPLIANCE
Tested by (name / position & signature)	Jazz Liang Project Manager 
Approved by (name / position & signature)	Tim Yan Project Manager 
Date of issue	2020-06-01
Report template No	TRF_EMCC 2017-06

## INDEX

	page
Competences and Guarantees.....	3
General conditions.....	3
Uncertainty.....	4
Environmental conditions.....	4
Possible test case verdicts .....	4
Definition of symbols used in this test report.....	4
Abbreviations .....	5
Document History .....	5
Remarks and Comments .....	5
1 General Information.....	6
1.1 General Description of the Item(s).....	6
1.2 Test data .....	9
1.3 The environment(s) in which the EUT is intended to be used .....	9
1.4 Classification of Receivers according to EN 300328 .....	9
2 Description of Test Setup .....	10
2.1 Operating mode(s) used for tests.....	10
2.2 Support / Auxiliary equipment / unit / software for the EUT .....	10
3 Verdict summary section .....	11
3.1 Standards .....	11
3.2 Deviation(s) from the Standard(s) / Test Specification(s) .....	11
3.3 Overview of results.....	11
4 Transmitter Test Results .....	12
4.1 RF output power.....	12
4.2 Power Spectral Density.....	14
4.3 Adaptivity.....	15
4.4 Occupied Channel Bandwidth (BW) .....	21
4.5 Transmitter unwanted emission in the out-of-band domain .....	25
4.6 Transmitter unwanted emission in the spurious domain.....	29
5 Receiver Test Results .....	30
5.1 Receiver spurious emission .....	30
5.2 Receiver Blocking .....	31
6 Identification of the Equipment Under Test .....	33
Annex 1 – Measurement Uncertainty .....	37

Annex 2 – Used Equipment.....	38
Annex 3 - Test Photos .....	39

## COMPETENCES AND GUARANTEES

---

DEKRA is a testing laboratory competent to carry out the tests described in this report.

In order to assure the traceability to other national and international laboratories, DEKRA has a calibration and maintenance program for its measurement equipment.

DEKRA guarantees the reliability of the data presented in this report, which is the result of the measurements and the tests performed to the item under test on the date and under the conditions stated in the report and it is based on the knowledge and technical facilities available at DEKRA at the time of performance of the test.

DEKRA is liable to the client for the maintenance of the confidentiality of all information related to the item under test and the results of the test.

The results presented in this Test Report apply only to the particular item under test established in this document.

**IMPORTANT:** No parts of this report may be reproduced or quoted out of context, in any form or by any means, except in full, without the previous written permission of DEKRA.

## GENERAL CONDITIONS

---

1. This report is only referred to the item that has undergone the test.
2. This report does not constitute or imply on its own an approval of the product by the Certification Bodies or Competent Authorities.
3. This document is only valid if complete; no partial reproduction can be made without previous written permission of DEKRA.
4. This test report cannot be used partially or in full for publicity and/or promotional purposes without previous written permission of DEKRA.
5. This report will not be used for social proof function in China market.

## UNCERTAINTY

For all measurements where guidance for the calculation of the instrumentation uncertainty of a measurement is specified in EN 55016-4-2 (CISPR 16-4-2), EN/IEC 61000-4 series or a product standard, the measurement instrumentation uncertainty has been calculated and applied in accordance with these standards.

Uncertainties have been calculated according to the DEKRA internal document. The reported expanded uncertainties are based on a standard uncertainty multiplied by a coverage factor of  $k=2$ , providing a level of confidence of approximately 95%.

## ENVIRONMENTAL CONDITIONS

The climatic conditions during the tests are within the limits specified by the manufacturer for the operation of the EUT and the test equipment. The climatic conditions during the tests were within the following limits:

Ambient temperature	15 °C – 35 °C
Relative Humidity air	30% - 60%
Atmospheric pressure	86 kPa – 106 kPa

If explicitly required in the basic standard or applied product / product family standard the climatic values are recorded and documented separately in this test report.

## POSSIBLE TEST CASE VERDICTS

Test case does not apply to test object	N/A
Test object does meet requirement	P (Pass) / PASS
Test object does not meet requirement	F (Fail) / FAIL
Not measured	N/M

## DEFINITION OF SYMBOLS USED IN THIS TEST REPORT

<input checked="" type="checkbox"/> Indicates that the listed condition, standard or equipment is applicable for this report/test/EUT.			
<input type="checkbox"/> Indicates that the listed condition, standard or equipment is not applicable for this report/test/EUT.			
Decimal separator used in this report	<input checked="" type="checkbox"/>	Comma (,)	<input type="checkbox"/> Point (.)

## ABBREVIATIONS

---

For the purposes of the present document, the following abbreviations apply:

EUT	: Equipment Under Test
QP	: Quasi-Peak
CAV	: CISPR Average
AV	: Average
CDN	: Coupling Decoupling Network
SAC	: Semi-Anechoic Chamber
OATS	: Open Area Test Site
BW	: Bandwidth
AM	: Amplitude Modulation
PM	: Pulse Modulation
HCP	: Horizontal Coupling Plane
VCP	: Vertical Coupling Plane
$U_N$	: Nominal voltage
$T_x$	: Transmitter
$R_x$	: Receiver
N/A	: Not Applicable
N/M	: Not Measured

## DOCUMENT HISTORY

---

Report nr.	Date	Description
4363930.50	2020-06-01	First release.

## REMARKS AND COMMENTS

---

The equipment under test (EUT) does meet the essential requirements of the stated standard(s)/test(s).

## 1 GENERAL INFORMATION

### 1.1 General Description of the Item(s)

Description of the item .....	LED fixed luminaire
Model / Type number .....	Refer table 1
Ratings .....	100-240 Vac, 50/60 Hz, 20 W (details refer to table 1)
Trade mark .....	<b>PHILIPS</b> or <b>WiZ</b>
Manufacturer .....	Signify (China) Investment Co., Ltd. Building No.9, Lane 888, Tianlin Road, Minhang District, Shanghai 200233, China
Factory .....	Zhejiang Klite Lighting Holdings Co.,Ltd. No.12 Tingchao Road, Jianshan New District, Haining City, Zhejiang Province, China

the characteristics of WIFI module are

Operating frequency range(s) – Tx.:	2412 – 2472 MHz
Operating frequency range(s) – Rx :	2412 – 2472 MHz
Type of Modulation .....	IEEE 802.11b: DSSS (CCK, QPSK, BPSK); IEEE 802.11g: OFDM (BPSK, QPSK, 16QAM, 64QAM); IEEE 802.11n: OFDM (BPSK, QPSK, 16QAM, 64QAM)
Number of channel .....	13
Max.RF Output power .....	19.5 dBm
Antenna type .....	Integral PCB antenna
Antenna gain .....	2,0 dBi
Operation temperature range	-10 – 40 °C

the characteristics of adapter are

Description of the item .....	AC/DC adapter
Model / Type number .....	DCT24W120170EU-A0, DCT24W120170UK-A0
Ratings .....	Input: 100-240 Vac, 50/60 Hz, 0.7A Output: 12.0Vdc, Output Power: 20.4W max.

Rated power supply .....	Voltage and Frequency		Reference poles				
			L1	L2	L3	N	PE
	<input checked="" type="checkbox"/>	AC: 100 – 240 V, 50/60 Hz	<input checked="" type="checkbox"/>	<input type="checkbox"/>	<input type="checkbox"/>	<input checked="" type="checkbox"/>	<input type="checkbox"/>
	<input type="checkbox"/>	AC:	<input type="checkbox"/>	<input type="checkbox"/>	<input type="checkbox"/>	<input type="checkbox"/>	<input type="checkbox"/>
	<input type="checkbox"/>	DC:					
Mounting position.....	<input type="checkbox"/>		Table top equipment				
	<input checked="" type="checkbox"/>		Wall/Ceiling mounted equipment				
	<input type="checkbox"/>		Floor standing equipment				
	<input type="checkbox"/>		Hand-held equipment				
	<input type="checkbox"/>		Other:				

The WIFI module operating channels are:

Channel	Frequency (MHz)	Channel	Frequency (MHz)
0	2412	7	2447
1	2417	8	2452
2	2422	9	2457
3	2427	10	2462
4	2432	11	2467
5	2437	12	2472
6	2442	-	-

Intended use of the Equipment Under Test (EUT)						
The apparatus as supplied for the test is LED fixed luminaire which intended for residential use, the product contains electronic control circuitry and without earth connection.						
According to customer description, all models are identical except that below table:						
Model Name	Input Voltage (V)	Rated Power	Adaptor	LED strip Length	Max interconnected length of LED module	Brand
9290025321	12Vdc	11W	N/A	1m	10m	WiZ
9290025251	12Vdc	11W	N/A	1m	10m	Philips
9290025264	12Vdc	20W	DCT24W120170UK-A0	2m	10m	WiZ
9290025681	12Vdc	20W	DCT24W120170EU-A0	2m	10m	Philips
9290025248	12Vdc	20W	DCT24W120170EU-A0	2m	10m	WiZ
Table 1						
Remark:						
All the adaptors are identical except different trade mark and plug. All the controllers have same construction except different model name and trade mark.						
9290025321 & 9290025251 are 1 meter extension LED strip which are able to be interconnected each other to Max. 10 meters.						
After technical evaluation, model 9290025248 is interconnected with model 9290025321 to Max. 10 meters was chosen for full testing, and the corresponding data are representative of the other models as well.						

Copy of marking plate:
N/A

## 1.2 Test data

Test Location	DEKRA Testing and Certification (Shanghai) Ltd. Guangzhou Branch No.3, Qiyun Road, Huangpu District, Guangzhou, Guangdong, China
Date of receipt of test item	2020-04-21
Date(s) of performance of tests	2020-04-21 to 2020-05-13

## 1.3 The environment(s) in which the EUT is intended to be used

The equipment under test (EUT) is intended to be used in the following environment(s):

<input checked="" type="checkbox"/>	Residential (domestic) environment.
<input checked="" type="checkbox"/>	Commercial and light-industrial environment.
<input type="checkbox"/>	Industrial environment.

## 1.4 Classification of Receivers according to EN 300328

The receivers were subdivided into 3 categories according to EN 300 328. For each category, the specific immunity requirements are formulated.

	Receiver category	Definition
√	1	Adaptive equipment with a maximum RF output power greater than 10 dBm(e.i.r.p).
	2	Non-adaptive equipment with a Medium Utilization (MU) factor greater than 1 % and less than or equal to 10 % or adaptive equipment with a maximum RF output power of 10 dBm(e.i.r.p).
	3	Non-adaptive equipment with a maximum Medium Utilization (MU) factor of 1 % or adaptive equipment with a maximum RF output power of 0 dBm(e.i.r.p).

## 2 DESCRIPTION OF TEST SETUP

### 2.1 Operating mode(s) used for tests

During the tests the following operating mode(s) has(have) been used.

Operating mode	Operating mode description	Used for methos	
		Conducted	Radiated
1	Transmitting mode	<input checked="" type="checkbox"/>	<input checked="" type="checkbox"/>
2	Receiving mode	<input checked="" type="checkbox"/>	<input checked="" type="checkbox"/>
3		<input type="checkbox"/>	<input type="checkbox"/>
Supplemental information: ---			

### 2.2 Support / Auxiliary equipment / unit / software for the EUT

The EUT has been tested with the following auxiliary equipment / unit / software: N/A

### 3 VERDICT SUMMARY SECTION

This chapter presents an overview of standards and results. Refer to the next chapters for details of measured test results and applied test levels.

#### 3.1 Standards

Standard	Year	Description
ETSI EN 300 328 V2.2.2	2019 - 07	Wideband transmission systems; Data transmission equipment operating in the 2,4 GHz band; Harmonised Standard for access to radio spectrum

#### 3.2 Deviation(s) from the Standard(s) / Test Specification(s)

The following deviation(s) was / were made from the published requirements of the listed standards: N/A.

#### 3.3 Overview of results

TRANSMITTER TESTS		
Requirement	Verdict	Remark
RF output power	PASS	---
Power Spectral Density	PASS	---
Adaptivity	PASS	---
Occupied Channel Bandwidth (BW)	PASS	---
Transmitter unwanted emissions in the out-of-band domain	PASS	---
Transmitter unwanted emissions in the spurious domain	PASS	---
Supplementary information: N/A		

RECEIVER TESTS		
Requirement	Verdict	Remark
Receiver spurious emission	PASS	--
Receiver Blocking	PASS	---
Geo-location capability	N/A	See 1)
Supplementary information: 1) the device is without geo-location capability.		

The measurement result is considered in conformance with the requirement if it is within the prescribed limit, It is not necessary to calculate the uncertainty associated with the measurement result.

## 4 TRANSMITTER TEST RESULTS

<b>4.1 RF output power</b>	<b>VERDICT: PASS</b>
----------------------------	----------------------

Standard	ETSI EN 300 328V2.2.2
Limits:	
For adaptive equipment using wide band modulation other than FHSS, the maximum RF output power shall be 20 dBm.	
The maximum RF output power for non-adaptive equipment shall be declared by the supplier and shall not exceed 20 dBm. For non-adaptive equipment using wide band modulations other than FHSS, the maximum RF output power shall be equal to or less than the value declared by the supplier.	
This limit shall apply for any combination of power level and intended antenna assembly	

### Performed measurements

Port under test	Antenna port	
Test method applied	<input checked="" type="checkbox"/>	Conducted measurement
	<input type="checkbox"/>	Radiated measurement
Test setup	Refer to the Annex 3 for test setup photo(s).	
Operating mode(s) used	Mode 1	
Remark	---	

See next page.

## Results

Temperature	Mode	Frequency (MHz)	Reading Level (dBm)	Antenna Gain (dBi)	RF output power (dBm)	Limit (dBm)
25 °C	IEEE 802.11b	2412	16,4	2	18,4	20
		2442	16,2		18,2	20
		2472	16,1		18,1	20
-10 °C	IEEE 802.11b	2412	16,3		18,3	20
		2442	16,1		18,1	20
		2472	16,2		18,2	20
40 °C	IEEE 802.11b	2412	15,8		17,8	20
		2442	15,7		17,7	20
		2472	15,9		17,9	20

Temperature	Mode	Frequency (MHz)	Reading Level (dBm)	Antenna Gain (dBi)	RF output power (dBm)	Limit (dBm)
25 °C	IEEE 802.11g	2412	15,1	2	17,1	20
		2442	14,2		16,2	20
		2472	14,3		16,3	20
-10 °C	IEEE 802.11g	2412	14,6		16,6	20
		2442	15,2		17,2	20
		2472	14,3		16,3	20
40 °C	IEEE 802.11g	2412	14,5		16,5	20
		2442	14,4		16,4	20
		2472	14,1		16,1	20

Temperature	Mode	Frequency (MHz)	Reading Level (dBm)	Antenna Gain (dBi)	RF output power (dBm)	Limit (dBm)
25 °C	IEEE 802.11n20	2412	14,5	2	16,5	20
		2442	14,1		16,1	20
		2472	14,2		16,2	20
-10 °C	IEEE 802.11n20	2412	14,8		16,8	20
		2442	14,6		16,6	20
		2472	14,9		16,9	20
40 °C	IEEE 802.11n20	2412	14,9		16,9	20
		2442	14,6		16,6	20
		2472	14,6		16,6	20

<b>4.2 Power Spectral Density</b>	<b>VERDICT: PASS</b>
-----------------------------------	----------------------

Standard	ETSI EN 300 328V2.2.2
Limits: For equipment using wide band modulations other than FHSS, the maximum Power Spectral Density is limited to 10 dBm per MHz.	

**Performed measurements**

Port under test	Antenna port
Test method applied	<input checked="" type="checkbox"/> Conducted measurement
	<input type="checkbox"/> Radiated measurement
Test setup	Refer to the Annex 3 for test setup photo(s).
Operating mode(s) used	Mode 1
Remark	---

**Results**

Mode	Frequency (MHz)	Power Spectral Density (dBm)	Limit (dBm/ MHz)
IEEE 802.11 b	2412	9,856	10
	2442	9,579	
	2472	9,572	
IEEE 802.11 g	2412	5,442	
	2442	4,566	
	2472	4,814	
IEEE 802.11 n20	2412	4,523	
	2442	4,328	
	2472	4,614	

<b>4.3 Adaptivity</b>	<b>VERDICT: PASS</b>
-----------------------	----------------------

Standard	ETSI EN 300 328V2.2.2
----------	-----------------------

Test setup

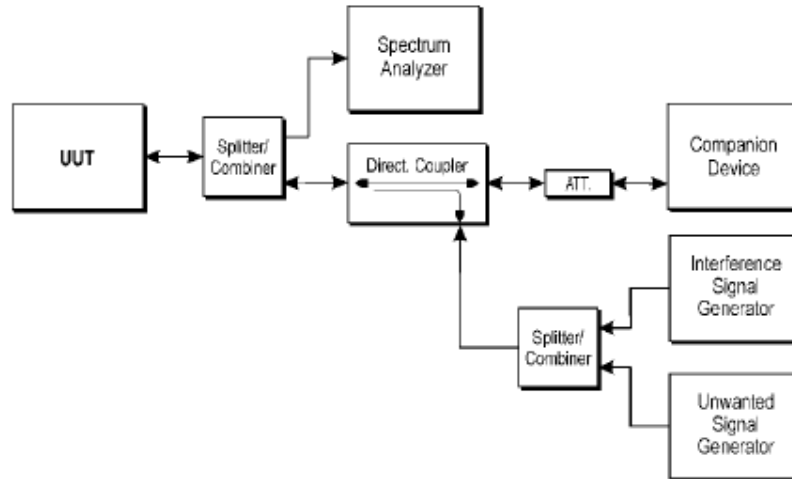

Limits:

Adaptive equipment using modulation other than FHSS

Load Based Equipment shall comply with the following requirements:

- 1) Before a transmission or a burst of transmissions, the equipment shall perform a Clear Channel Assessment (CCA) check using energy detect. The equipment shall observe the operating channel for the duration of the CCA observation time which shall be not less than 18  $\mu$ s. The channel shall be considered occupied if the energy level in the channel exceeds the threshold given in step 5 below. If the equipment finds the channel to be clear, it may transmit immediately.
- 2) If the equipment finds the channel occupied, it shall not transmit on this channel (see also the next paragraph). The equipment shall perform an Extended CCA check in which the channel is observed for a random duration in the range between 18  $\mu$ s and at least 160  $\mu$ s. If the extended CCA check has determined the channel to be no longer occupied, the equipment may resume transmissions on this channel. If the Extended CCA time has determined the channel still to be occupied, it shall perform new Extended CCA checks until the channel is no longer occupied.

NOTE: The Idle Period in between transmissions is considered to be the CCA or the Extended CCA check as there are no transmissions during this period.

The equipment is allowed to switch to a non-adaptive mode and to continue transmissions on this channel providing it complies with the requirements applicable to non-adaptive equipment. Alternatively, the equipment is also allowed to continue Short Control Signalling Transmissions on this channel providing it complies with the requirements given in clause 4.3.2.6.4.

- 3) The total time that an equipment makes use of a RF channel is defined as the Channel Occupancy Time. This Channel Occupancy Time shall be less than 13 ms, after which the device shall perform a new CCA as described in step 1 above.

- 4) The equipment, upon correct reception of a transmission which was intended for this equipment can skip CCA and immediately (see also next paragraph) proceed with the transmission of management and control frames. A consecutive sequence of transmissions by the equipment without a new CCA shall not exceed the maximum channel occupancy time as defined in step 3 above.

For the purpose of multi-cast, the ACK transmissions (associated with the same data packet) of the individual devices are allowed to take place in a sequence.

- 5) The energy detection threshold for the CCA shall be proportional to the transmit power of the transmitter: for a 20 dBm e.i.r.p. transmitter the CCA threshold level (TL) shall be equal to or less than -70 dBm/MHz at the input to the receiver assuming a 0 dBi (receive) antenna assembly. This threshold level (TL) may be corrected for the (receive) antenna assembly gain (G); however, beamforming gain (Y) shall not be taken into account. For power levels less than 20 dBm e.i.r.p., the CCA threshold level may be relaxed to:

$$TL = -70 \text{ dBm/MHz} + 10 \times \log_{10} (100 \text{ mW} / P_{\text{out}}) \quad (P_{\text{out}} \text{ in mW e.i.r.p.})$$

- 6) The equipment shall comply with the requirements defined in step 1 to step 4 of the present clause in the presence of an unwanted CW signal as defined in table 11.

**Table 11: Unwanted Signal parameters**

Wanted signal mean power from companion device	Unwanted signal frequency (MHz)	Unwanted signal power (dBm)
sufficient to maintain the link (see note 2)	2 395 or 2 488,5 (see note 1)	-35 (see note 3)
<p>NOTE 1: The highest frequency shall be used for testing operating channels within the range 2 400 MHz to 2 442 MHz, while the lowest frequency shall be used for testing operating channels within the range 2 442 MHz to 2 483,5 MHz. See clause 5.4.6.1.</p> <p>NOTE 2: A typical conducted value which can be used in most cases is -50 dBm/MHz.</p> <p>NOTE 3: The level specified is the level at the UUT receiver input assuming a 0 dBi antenna assembly gain. In case of conducted measurements, this level has to be corrected for the (in-band) antenna assembly gain (G). In case of radiated measurements, this level is equivalent to a power flux density (PFD) in front of the UUT antenna.</p>		

**Performed measurements**

Port under test	Antenna port	
Test method applied	<input checked="" type="checkbox"/>	Conducted measurement
	<input type="checkbox"/>	Radiated measurement
Test setup	Refer to the Annex 3 for test setup photo(s).	
Operating mode(s) used	Mode 1	
Remark	---	

See next page.

## Results

Mode	Data Rate	Frequency (MHz)	Channel Occupancy Time (COT) (ms)	Limit (ms)	Adaptivity Short Control [%]	Limit (%)
802.11b	11 Mbps	2412	1.907	<13	1.22	10
	11 Mbps	2472	1.907		1.22	
802.11g	54 Mbps	2412	1.698		0.18	
	54 Mbps	2472	1.697		0.18	
802.11n20	72.2 Mbps	2412	3.498		0.12	
	72.2 Mbps	2472	2.593		0.12	

**Remark:** Before, on and after the test, once the transmission link was building, the status of the transmission link indicator no any changes, that means the transmission link was maintained (if break, the transmission link indicator will flash to indicate a new search on starting).

Test process (representative of all modes)

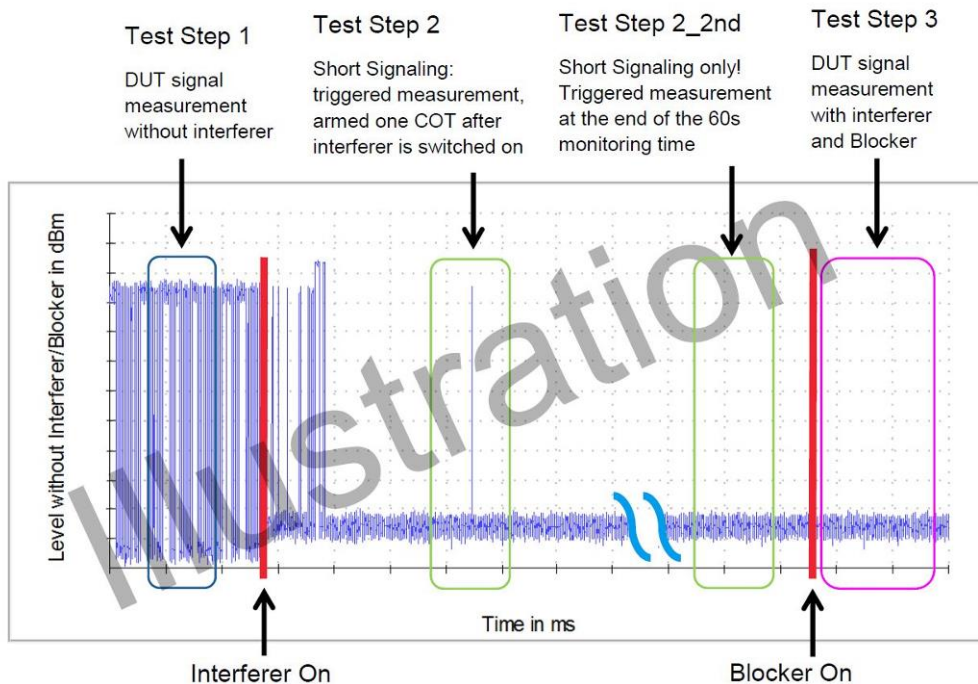

## Data

B\_2412MHz:

Interferer on

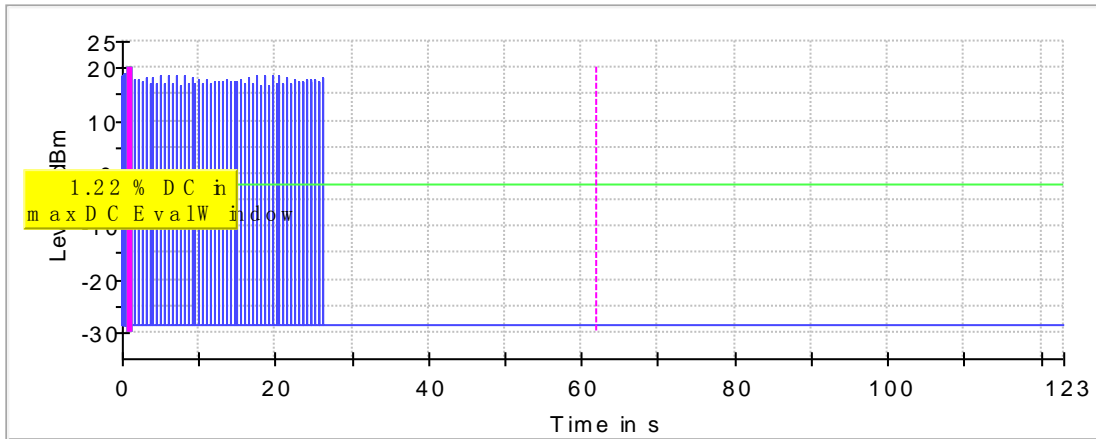

- Trace
- - - Trigger
- | stop of evaluation
- Threshold
- - - Blocker
- | start of monitoring
- | start of evaluation

B\_2472MHz:

Interferer on

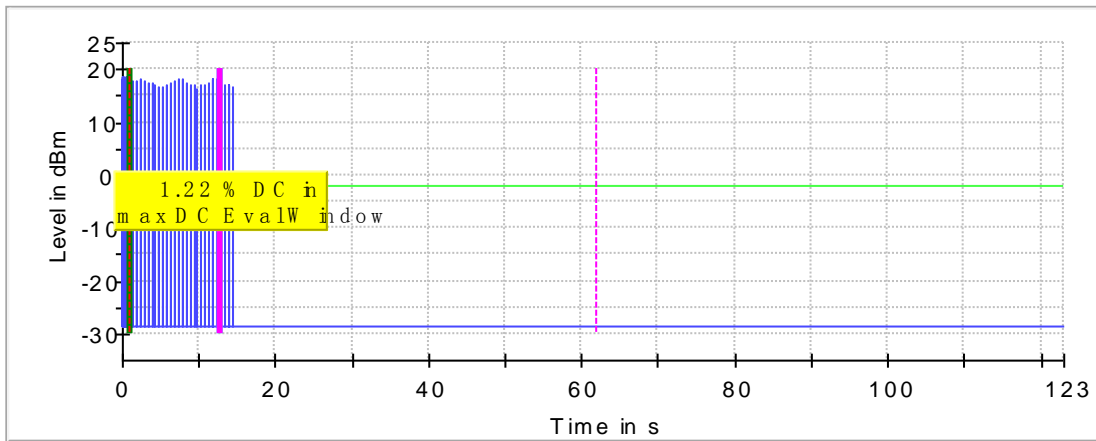

- Trace
- - - Trigger
- | stop of evaluation
- Threshold
- - - Blocker
- | start of monitoring
- | start of evaluation

G\_2412MHz:

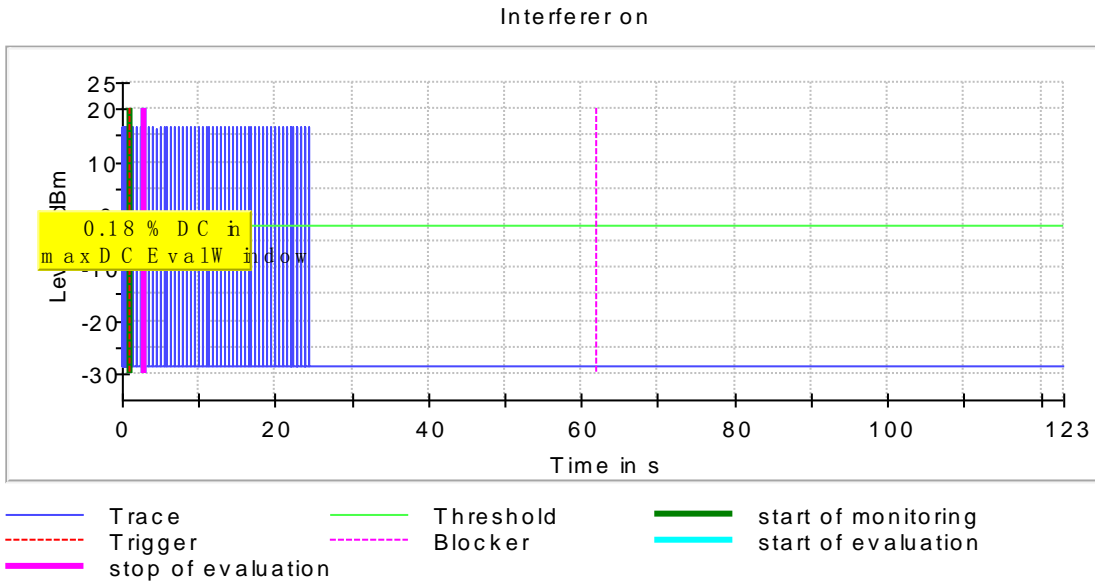

G\_2472MHz:

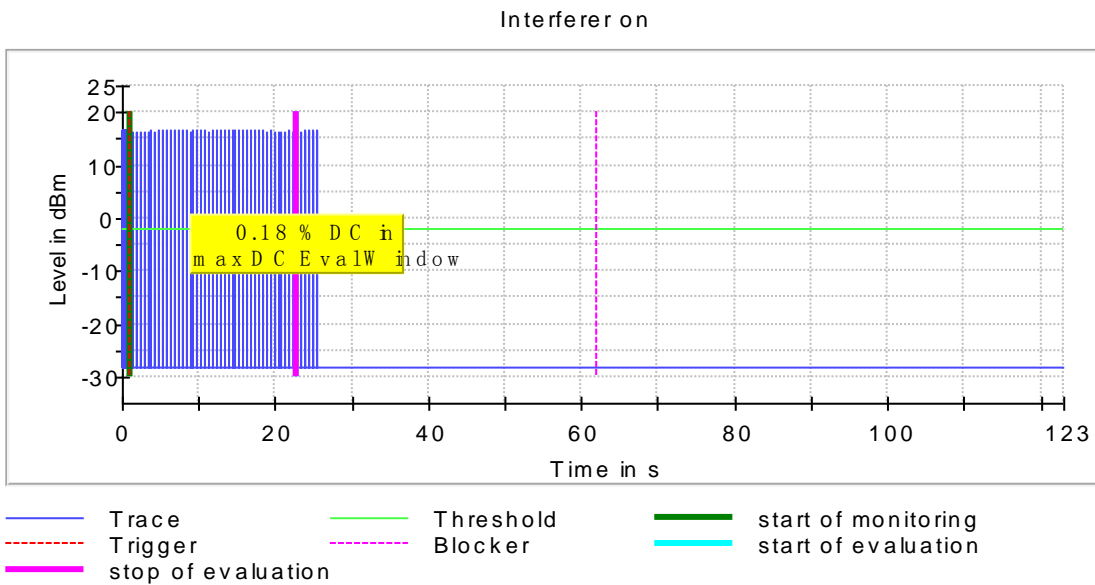

N20\_2412MHz:

Interferer on

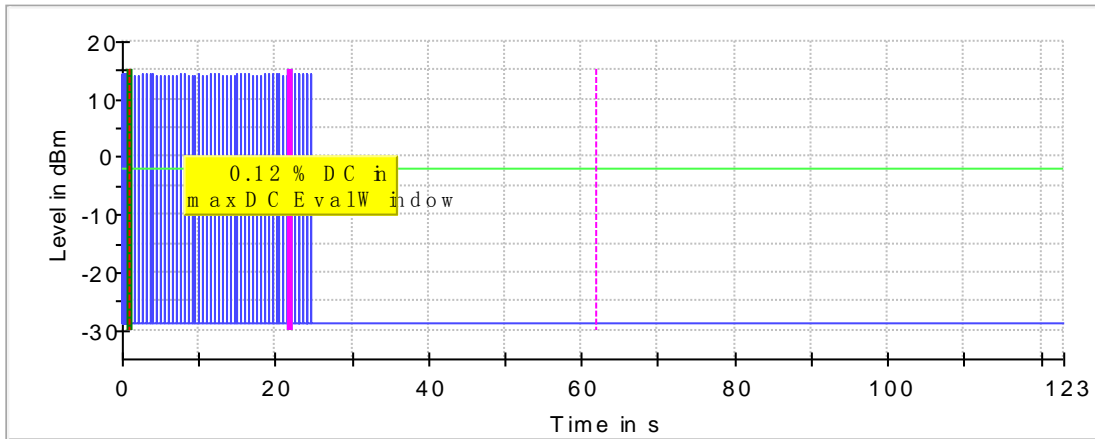

- Trace
- - - Trigger
- | stop of evaluation
- Threshold
- - - Blocker
- start of monitoring
- start of evaluation

N20\_2472MHz:

Interferer on

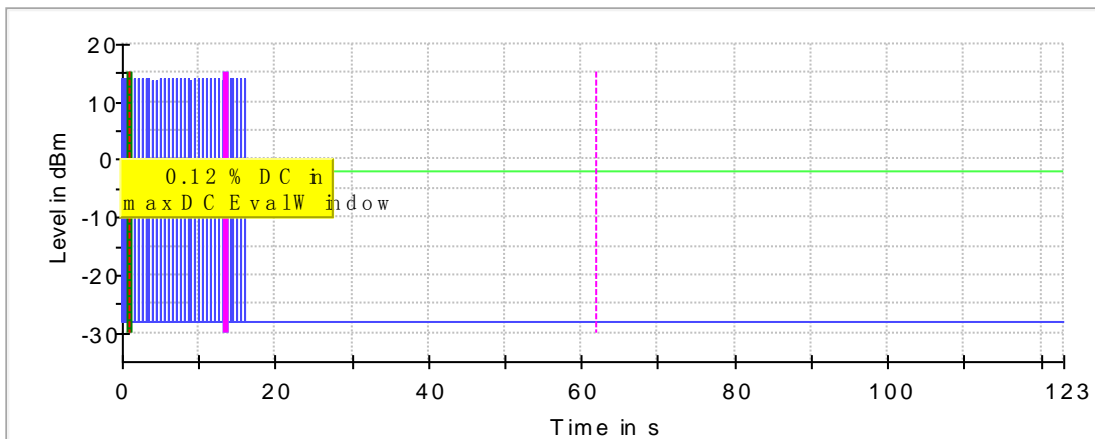

- Trace
- - - Trigger
- | stop of evaluation
- Threshold
- - - Blocker
- start of monitoring
- start of evaluation

<b>4.4 Occupied Channel Bandwidth (BW)</b>	<b>VERDICT: PASS</b>
--	----------------------

Standard	ETSI EN 300 328V2.2.2
Limits: The Occupied Channel Bandwidth shall fall completely within the band given in Clause 1 (2,4 GHz to 2,4835 GHz).	
In addition, for non-adaptive systems using wide band modulations other than FHSS and with e.i.r.p greater than 10 dBm, the occupied channel bandwidth shall be less than 20 MHz.	

**Performed measurements**

Port under test	Antenna port	
Test method applied	<input checked="" type="checkbox"/> Conducted measurement	<input type="checkbox"/> Radiated measurement
Test setup	Refer to the Annex 3 for test setup photo(s).	
Operating mode(s) used	Mode 1	
Remark	---	

**Results of WIFI1# module**

Mode	Frequency (MHz)	Bandwidth 99%(MHz)	FL (MHz) or FH (MHz)	Lower Limit (MHz)	Higher Limit
IEEE 802.11 b	2412	13.176	2405.411765	> 2400,0	N/A
	2472	13.326	2478.588235	N/A	< 2483,5
IEEE 802.11 g	2412	16.470	2403.764706	> 2400,0	N/A
	2472	16.620	2480.235294	N/A	< 2483,5
IEEE 802.11 n20	2412	17,818	2403.016043	> 2400,0	N/A
	2472	17.818	2480.834225	N/A	< 2483,5

See next page.

Data  
IEEE 802.11b  
2412MHz

99 % Bandwidth



2472MHz:

99 % Bandwidth

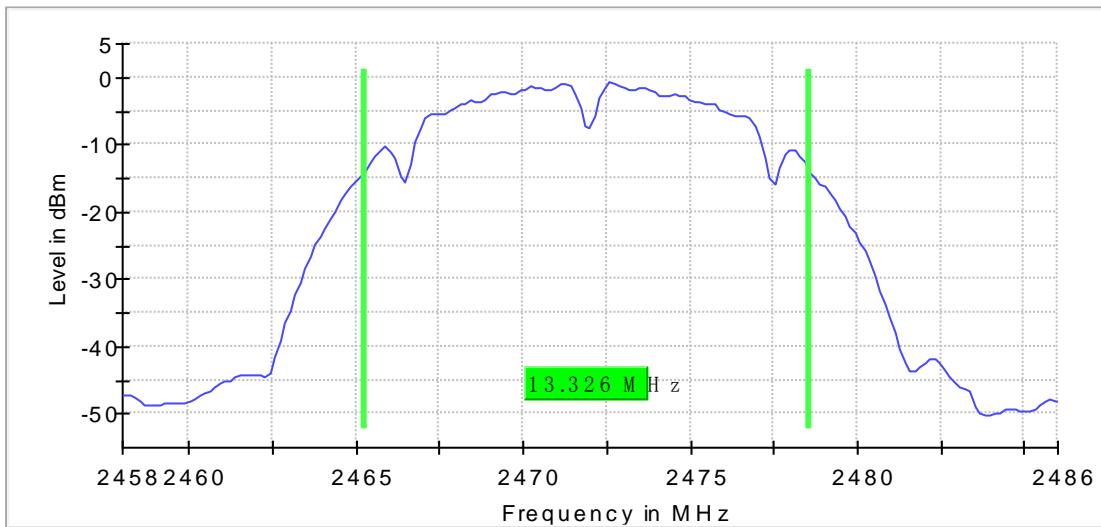

IEEE 802.11g  
2412MHz

99 % Bandwidth

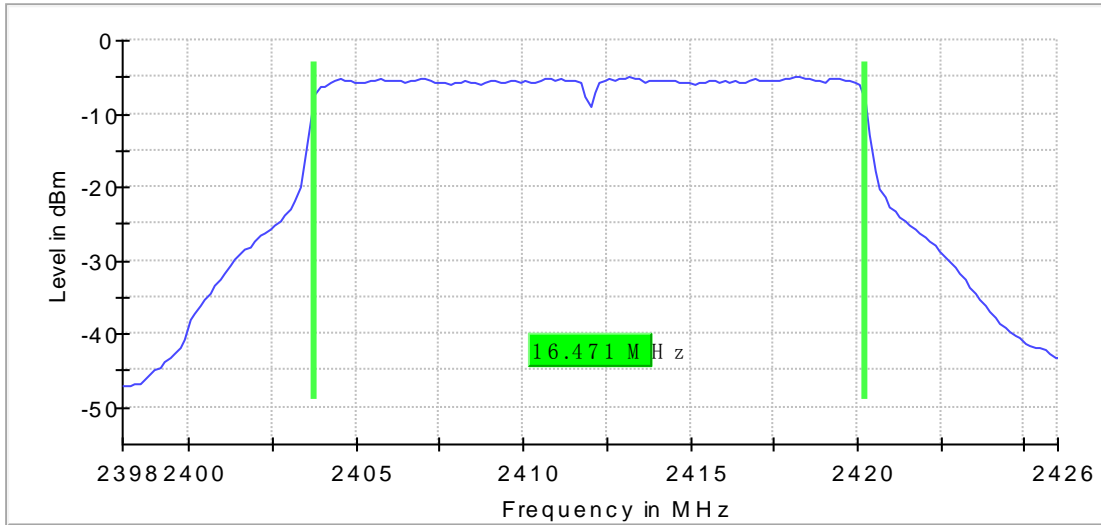

2472MHz:

99 % Bandwidth

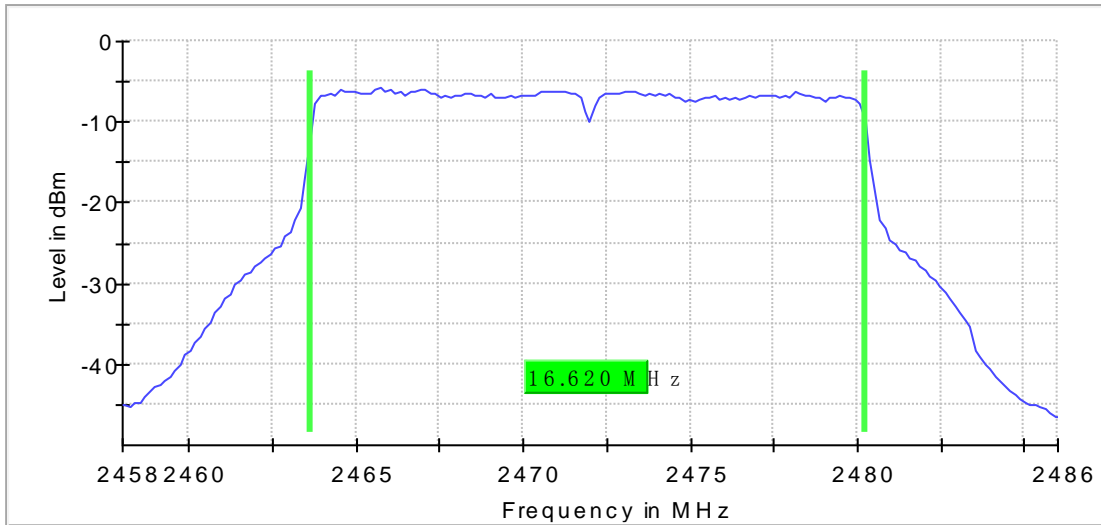

IEEE 802.11N20  
2412MHz

99 % Bandwidth

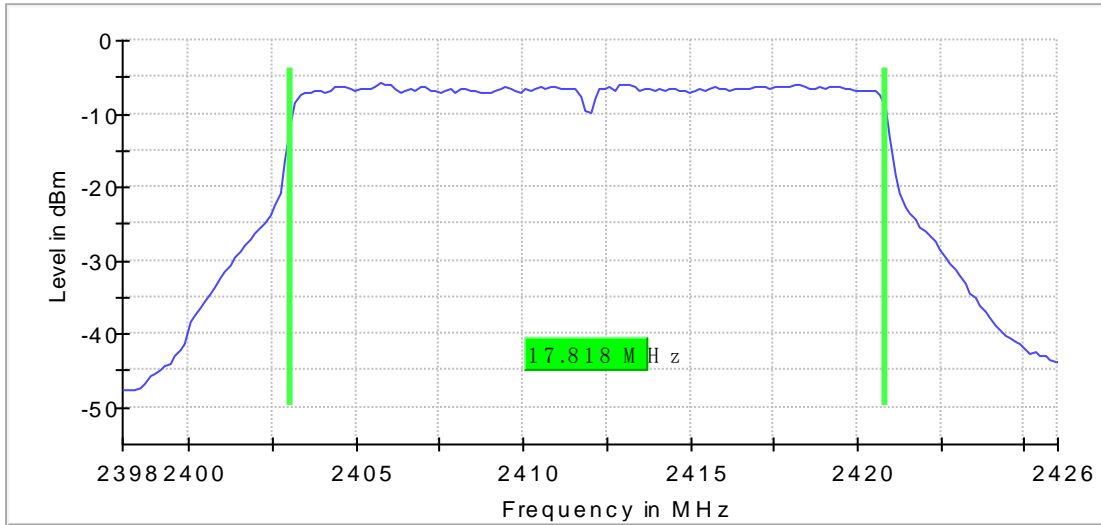

2472MHz:

99 % Bandwidth

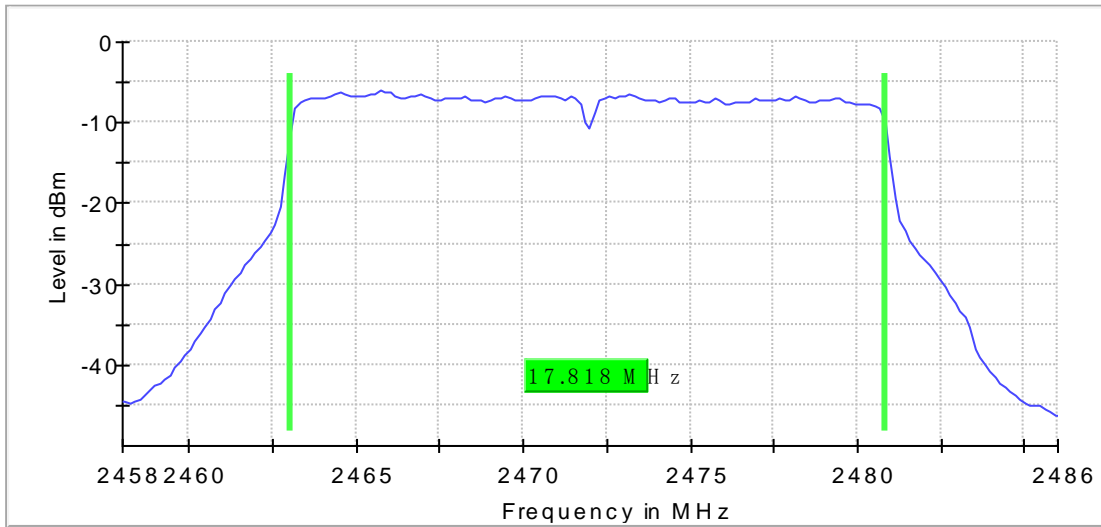

<b>4.5</b>	<b>Transmitter unwanted emission in the out-of-band domain</b>	<b>VERDICT: PASS</b>
------------	--	----------------------

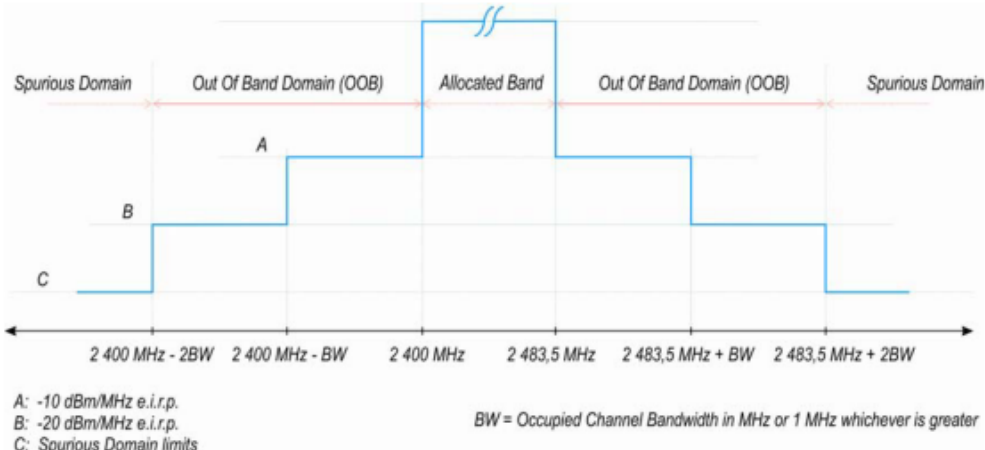
Standard	ETSI EN 300 328V2.2.2
Limits:	
<p>The transmitter unwanted emissions in the out-of-band domain but outside the allocated band, shall not exceed the values provided by the mask in figure 3.</p> <p>NOTE: Within the 2 400 MHz to 2 483,5 MHz band, the Out-of-band emissions are fulfilled by compliance with the Occupied Channel Bandwidth requirement in clause 4.3.2.6.</p>	
 <p style="text-align: center;">A: -10 dBm/MHz e.i.r.p.                  B: -20 dBm/MHz e.i.r.p.                  C: Spurious Domain limits</p> <p style="text-align: center;">BW = Occupied Channel Bandwidth in MHz or 1 MHz whichever is greater</p>	
<b>Figure 3: Transmit mask</b>	

**Performed measurements**

Port under test	Antenna port
Test method applied	<input checked="" type="checkbox"/> Conducted measurement
	<input type="checkbox"/> Radiated measurement
Test setup	Refer to the Annex 3 for test setup photo(s).
Operating mode(s) used	Mode 1
Remark	---

See next page.

## Results IEEE 802.11B

Out of band low

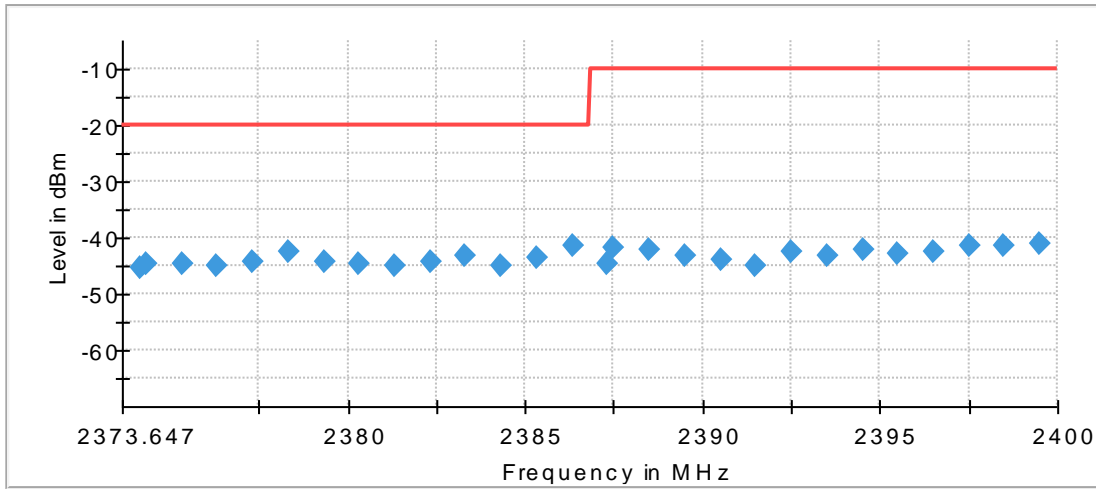

◆ Level — Limit

Out of band high

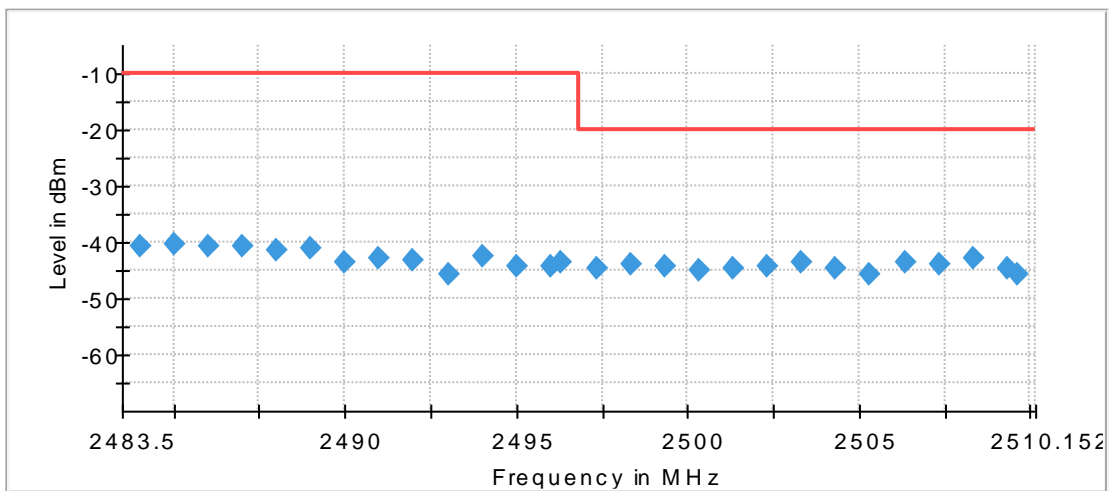

◆ Level — Limit

IEEE 802.11G

Out of band low

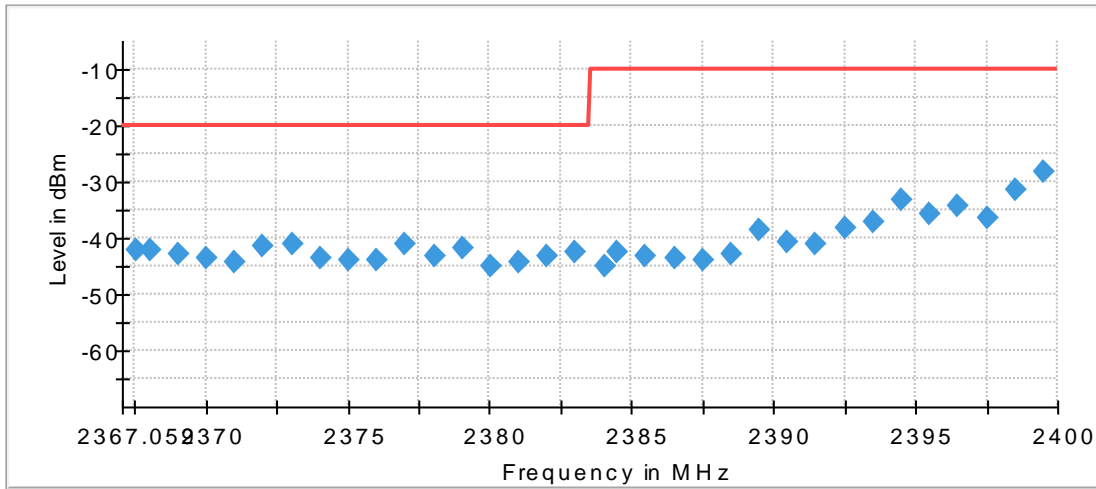

◆ Level — Limit

Out of band high

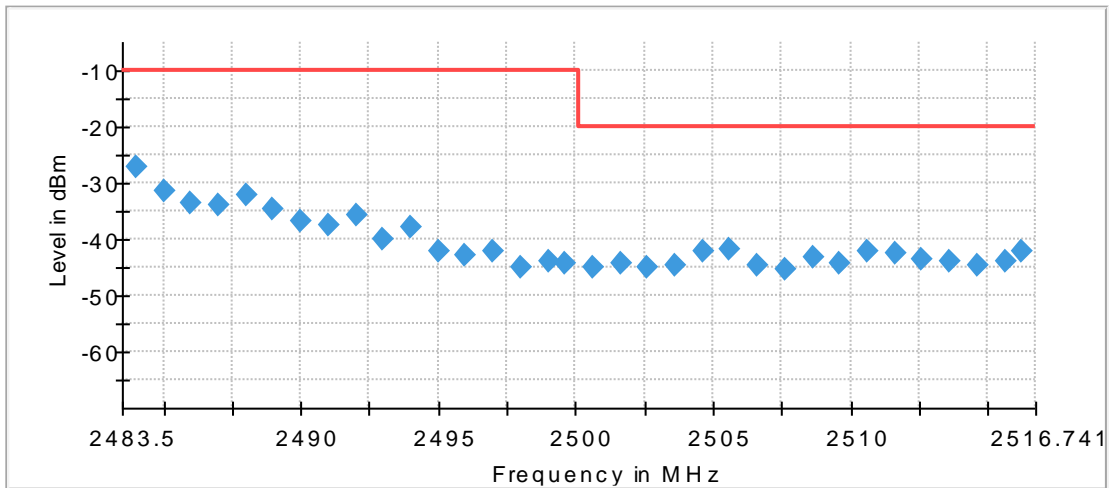

◆ Level — Limit

IEEE 802.11N20

Out of band low

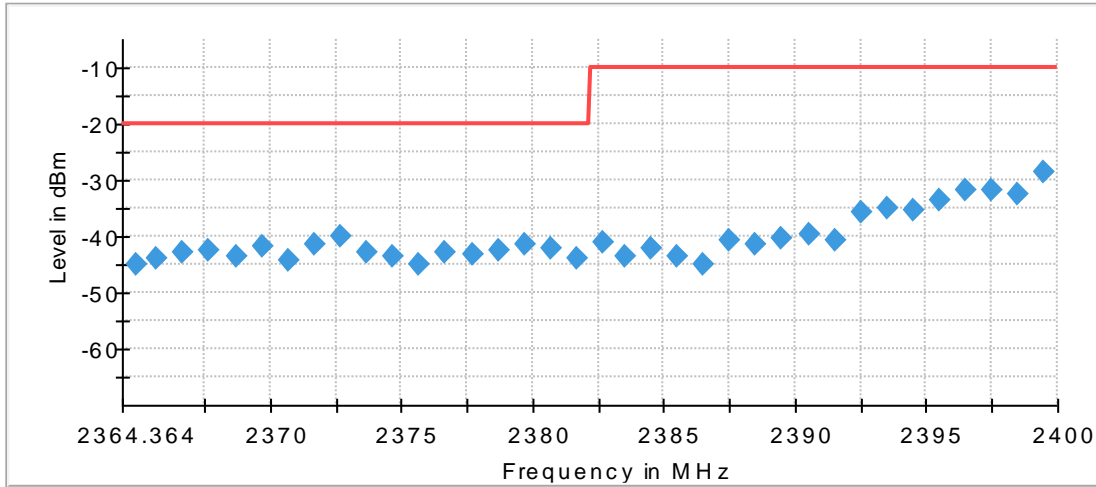

◆ Level — Limit

Out of band high

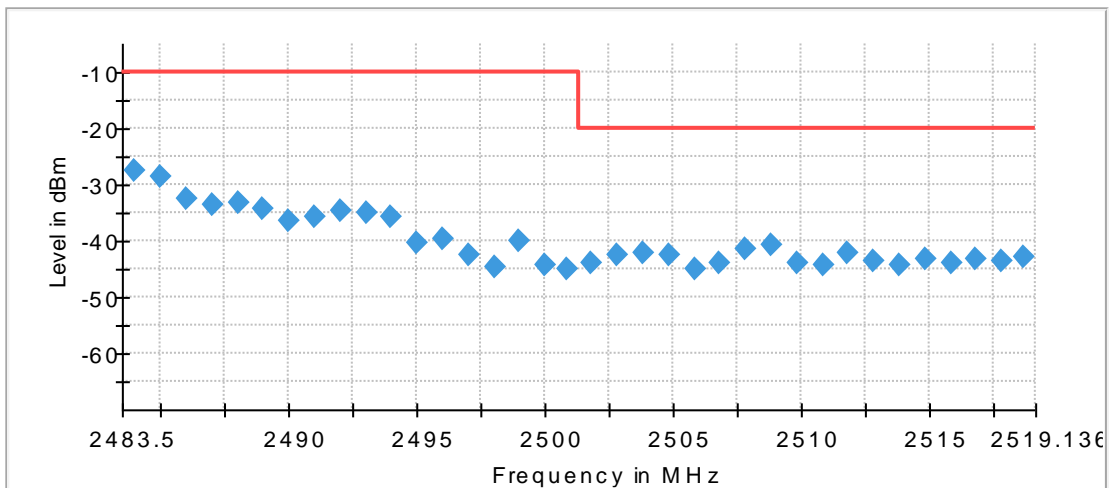

◆ Level — Limit

4.6	<b>Transmitter unwanted emission in the spurious domain</b>	<b>VERDICT: PASS</b>
-----	---	----------------------

Standard	ETSI EN 300 328V2.2.2	
Limits:		
<b>Frequency range</b>	<b>Maximum power</b>	<b>Bandwidth</b>
30 MHz to 47 MHz	-36 dBm	100 kHz
47 MHz to 74 MHz	-54 dBm	100 kHz
74 MHz to 87,5 MHz	-36 dBm	100 kHz
87,5 MHz to 118 MHz	-54 dBm	100 kHz
118 MHz to 174 MHz	-36 dBm	100 kHz
174 MHz to 230 MHz	-54 dBm	100 kHz
230 MHz to 470 MHz	-36 dBm	100 kHz
470 MHz to 694 MHz	-54 dBm	100 kHz
694 MHz to 1 GHz	-36 dBm	100 kHz
1 GHz to 12,75 GHz	-30 dBm	1 MHz

**Performed measurements**

Port under test	Antenna port	
Test method applied	<input type="checkbox"/>	Conducted measurement
	<input checked="" type="checkbox"/>	Radiated measurement
Test setup	Refer to the Annex 3 for test setup photo(s).	
Operating mode(s) used	Mode 1, IEEE 802.11 B (the worst case)	
Remark	---	

**Result of transmitting mode**

CH or Frequency (MHz)	Results					
	Frequency (MHz)	Reading level(dBm)	Factor(dB)	Results (dBm)	Limit (dBm)	Position
2412	4814.00	-52.05	7.88	-44.17	-30	Horizontal
	4814.00	-55.30	8.31	-46.99	-30	Vertical
2472	4944.00	-42.30	8.58	-33.72	-30	Horizontal
	4944.00	-48.25	8.22	-40.03	-30	Vertical

Remark: Result (dBm)= Reading level(dBm) + Factor(dB)

## 5 RECEIVER TEST RESULTS

<b>5.1 Receiver spurious emission</b>	<b>VERDICT: PASS</b>
---------------------------------------	----------------------

Standard	ETSI EN 300 328V2.2.2	
Limits:		
<b>Frequency range</b>	<b>Maximum power e.r.p. (<math>\leq 1</math> GHz) e.i.r.p. (<math>&gt; 1</math> GHz)</b>	<b>Measurement bandwidth</b>
30 MHz to 1 GHz	-57 dBm	100 kHz
1 GHz to 12,75 GHz	-47 dBm	1 MHz

### Performed measurements

Port under test	Antenna port	
Test method applied	<input type="checkbox"/>	Conducted measurement
	<input checked="" type="checkbox"/>	Radiated measurement
Test setup	Refer to the Annex 3 for test setup photo(s).	
Operating mode(s) used	Mode 2	
Remark	---	

### Result of receiving mode

CH or Frequency (MHz)	Results					
	Frequency (MHz)	Reading level(dBm)	Factor(dB)	Results (dBm)	Limit (dBm)	Remark
2412	No significant emissions were measured at the frequency range of interest employing the RMS detectors (more than 20 dB below limits)					
2472	No significant emissions were measured at the frequency range of interest employing the RMS detectors (more than 20 dB below limits)					

Remark: Result(dBm)= Reading level(dBm) + Factor(dB)

<b>5.2 Receiver Blocking</b>	<b>VERDICT: PASS</b>
------------------------------	----------------------

Standard	ETSI EN 300 328V2.2.2										
Test setup											
<b>Table 14: Receiver Blocking parameters for Receiver Category 1 equipment</b>											
<table border="1" style="width: 100%; border-collapse: collapse;"> <thead> <tr> <th style="width: 45%;">Wanted signal mean power from companion device (dBm) (see notes 1 and 4)</th> <th style="width: 15%;">Blocking signal frequency (MHz)</th> <th style="width: 20%;">Blocking signal power (dBm) (see note 4)</th> <th style="width: 20%;">Type of blocking signal</th> </tr> </thead> <tbody> <tr> <td style="text-align: center;">(-133 dBm + 10 × log<sub>10</sub>(OCBW)) or -68 dBm whichever is less (see note 2)</td> <td style="text-align: center;">2 380 2 504</td> <td rowspan="2" style="text-align: center;">-34</td> <td rowspan="2" style="text-align: center;">CW</td> </tr> <tr> <td style="text-align: center;">(-139 dBm + 10 × log<sub>10</sub>(OCBW)) or -74 dBm whichever is less (see note 3)</td> <td style="text-align: center;">2 300 2 330 2 360 2 524 2 584 2 674</td> </tr> </tbody> </table>		Wanted signal mean power from companion device (dBm) (see notes 1 and 4)	Blocking signal frequency (MHz)	Blocking signal power (dBm) (see note 4)	Type of blocking signal	(-133 dBm + 10 × log <sub>10</sub> (OCBW)) or -68 dBm whichever is less (see note 2)	2 380 2 504	-34	CW	(-139 dBm + 10 × log <sub>10</sub> (OCBW)) or -74 dBm whichever is less (see note 3)	2 300 2 330 2 360 2 524 2 584 2 674
Wanted signal mean power from companion device (dBm) (see notes 1 and 4)	Blocking signal frequency (MHz)	Blocking signal power (dBm) (see note 4)	Type of blocking signal								
(-133 dBm + 10 × log <sub>10</sub> (OCBW)) or -68 dBm whichever is less (see note 2)	2 380 2 504	-34	CW								
(-139 dBm + 10 × log <sub>10</sub> (OCBW)) or -74 dBm whichever is less (see note 3)	2 300 2 330 2 360 2 524 2 584 2 674										
<p>NOTE 1: OCBW is in Hz.</p> <p>NOTE 2: In case of radiated measurements using a companion device and the level of the wanted signal from the companion device cannot be determined, a relative test may be performed using a wanted signal up to P<sub>min</sub> + 26 dB where P<sub>min</sub> is the minimum level of wanted signal required to meet the minimum performance criteria as defined in clause 4.3.1.12.3 in the absence of any blocking signal.</p> <p>NOTE 3: In case of radiated measurements using a companion device and the level of the wanted signal from the companion device cannot be determined, a relative test may be performed using a wanted signal up to P<sub>min</sub> + 20 dB where P<sub>min</sub> is the minimum level of wanted signal required to meet the minimum performance criteria as defined in clause 4.3.1.12.3 in the absence of any blocking signal.</p> <p>NOTE 4: The level specified is the level at the UUT receiver input assuming a 0 dBi antenna assembly gain. In case of conducted measurements, this level has to be corrected for the (in-band) antenna assembly gain (G). In case of radiated measurements, this level is equivalent to a power flux density (PFD) in front of the UUT antenna with the UUT being configured/positioned as recorded in clause 5.4.3.2.2.</p>											
Remark: the EUT belongs to category 1 according to the result of output power refer section 4.1.											
Limits:											
<p>For equipment that supports a PER or FER test to be performed, the minimum performance criterion shall be a PER or FER less than or equal to 10 %.</p> <p>For equipment that does not support a PER or a FER test to be performed, the minimum performance criterion shall be no loss of the wireless transmission function needed for the intended use of the equipment.</p>											

**Performed measurements**

Port under test	Antenna port
Test method applied	<input checked="" type="checkbox"/> Conducted measurement
	<input type="checkbox"/> Radiated measurement
Test setup	Refer to the Annex 3 for test setup photo(s).
Operating mode(s) used	Mode 1&2, IEEE 802.11 B (the worst case)
Remark	---

See next page.

## Results

#	Blocking Frequency (MHz)	Blocking Frequency Offset (MHz)	Level of Wanted Signal at DUT (dBm)	Wanted Level Offset (dB)	WIFI PER(%)	Limit Max(%)	Result
1	2380.000000	0.000000	-66.0	0.0	100.000	10.000	FAIL
2	2380.000000	10.000000	-63.0	3.0	100.000	10.000	FAIL
3	2380.000000	-10.000000	-69.0	-3.0	0.800	10.000	PASS
4	2300.000000	0.000000	-72.0	0.0	100.000	10.000	FAIL
5	2300.000000	14.000000	-72.0	0.0	47.400	10.000	FAIL
6	2300.000000	-14.000000	-72.0	0.0	7.600	10.000	PASS
7	2330.000000	0.000000	-72.0	0.0	2.400	10.000	PASS
8	2360.000000	0.000000	-72.0	0.0	8.200	10.000	PASS

## 6 IDENTIFICATION OF THE EQUIPMENT UNDER TEST

The photographs show the tested device.



Model 9290025248



Adaptor



PCB of adaptor

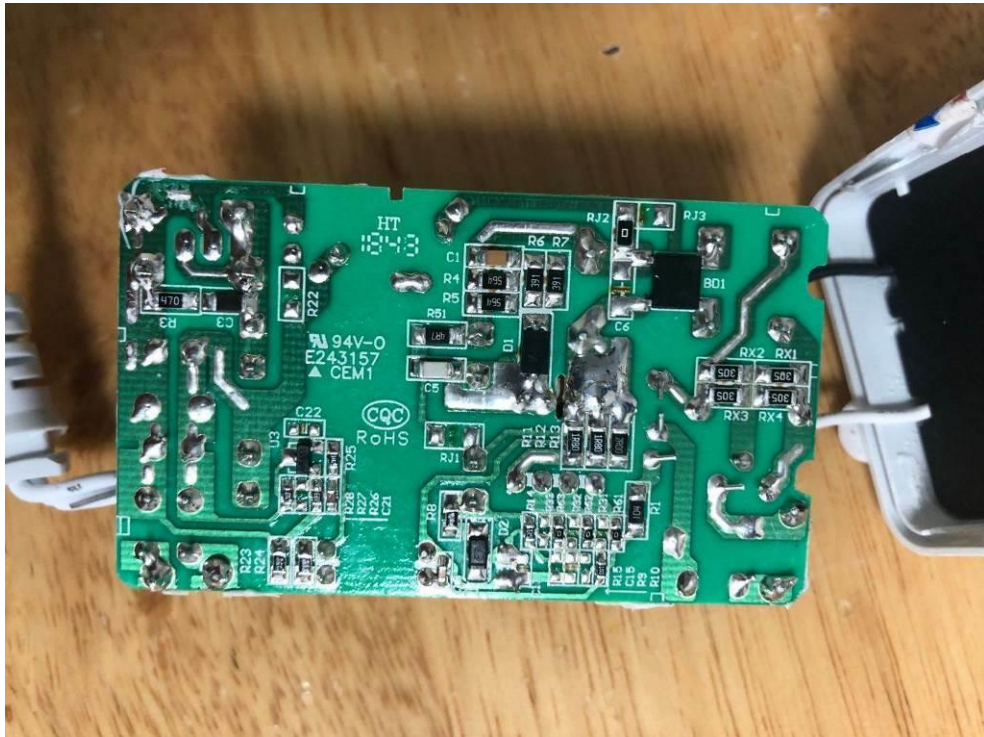

PCB of adaptor



LED light



Control box



PCB of control box

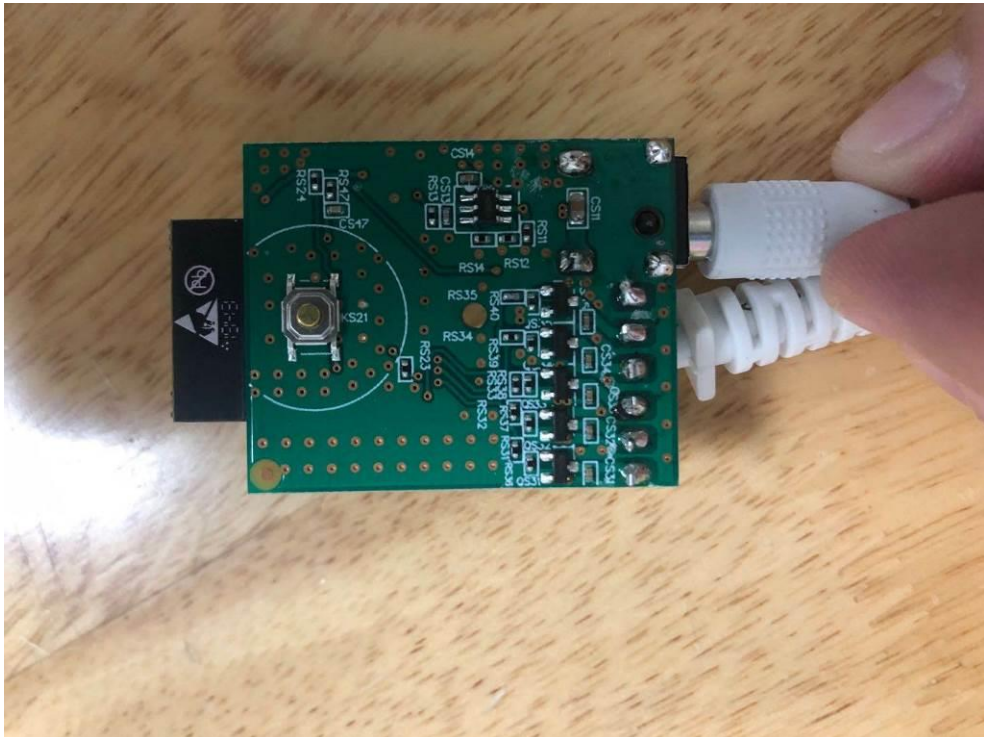

PCB of control box

## ANNEX 1 – MEASUREMENT UNCERTAINTY

Test Item	Uncertainty
Occupied Channel Bandwidth	$\pm 0,7\%$
RF Output power	$\pm 0,6\text{dB}$
Spurious (30-1000MHz)	$\pm 4,4\text{dB}$
Spurious (1-12,75GHz)	$\pm 4,4\text{dB}$

## ANNEX 2 – USED EQUIPMENT

Location: DEKRA Testing and Certification (Shanghai) Ltd. Guangzhou Branch

Item	Instrumentation	Manufacturer	Model	Serial no.	Dekra No.	Cal. Due date
1	EMI receiver	R&S	ESCI	101205	G/L857	2020/10/12
2	Antenna (30MHz-3GHz)	SCHWARZBE CK	VULB916 3	506	G/L864	2020/10/30
3	Antenna (1GHz-18GHz)	R&S	HF907	102306	G/L1236	2020/09/19
4	Horn antenna preamplifier	Schwarzbeek	SCU-18	102234	G/L1236-1	2020/09/19
5	Spectrum analyzer	R&S	FSV	SN101012	G/L1235	2020/11/04
6	Chamber	ETS	/	/	G/L856	2021/06/19
7	Chamber	CEPREI	/	/	GZ1674	2020/07/13
8	Open Switch and Control Platform	R&S	OSP 150	/	GZ1894	2020/06/04
9	Signal Generator	R&S	SMB 100A	/	GZ1895	2020/06/04
10	Vector Signal Generator	R&S	SMBV 100A	/	GZ1896	2020/06/04
11	Wireless Connectivity Tester	R&S	CMW 270	/	GZ1897	2020/06/04

## ANNEX 3 - TEST PHOTOS

### Conducted measurements



Radiated measurements



### Extreme test conditions



--- END ---